

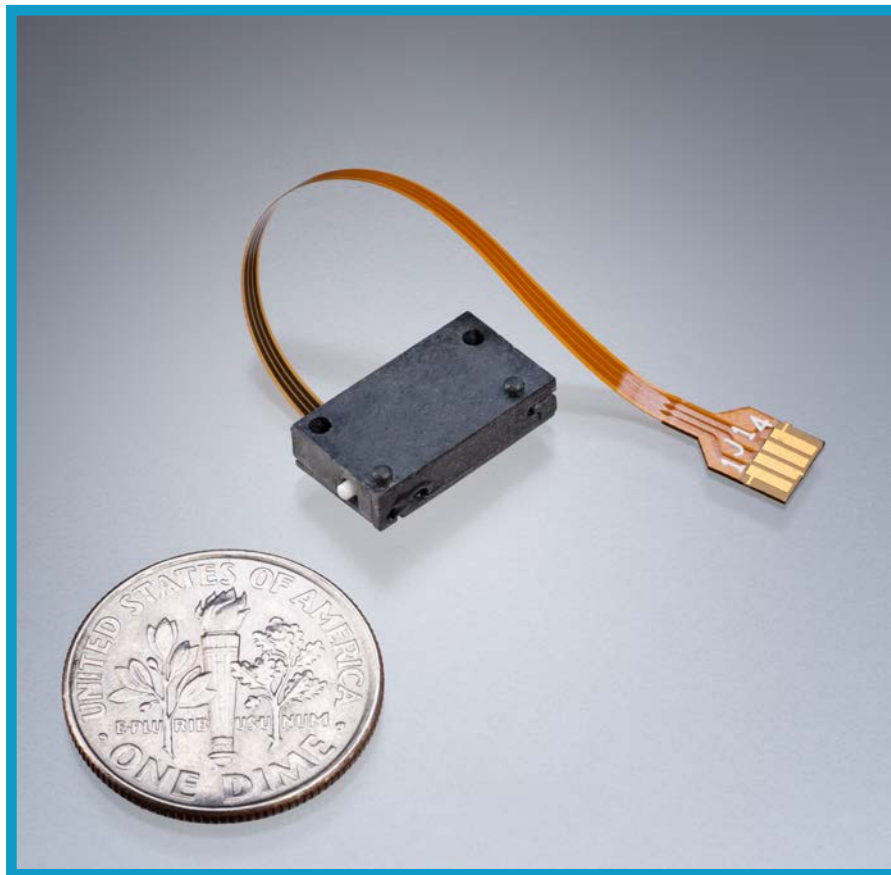

A Johnson Electric Company

EDGE Motor

User Manual



EDGE458001-00 REV:A

July 2011

Nanomotion Ltd. POB 623, Yokneam 20692, Israel

Tel: 972-73-2498000 Fax: 972-73-2498099

Web Site: www.nanomotion.com

E-mail: nano@nanomotion.com

Copyright

This document contains proprietary information of Nanomotion Ltd., and may not be reproduced in any form without prior written consent from Nanomotion Ltd.

No part of this document may be reproduced, translated, stored in a retrieval system or transmitted in any form and by any means, electronic, mechanical, photographic, photocopying, recording, or otherwise, without the written permission of Nanomotion Ltd.

Information provided in this document is subject to change without notice and does not represent a commitment on the part of Nanomotion Ltd.

Copyright: 2011-2012, Yokneam, Israel. All rights reserved.

All products and company names are trademarks or registered trademarks of their respective holders.

Limited Warranty

Nanomotion Ltd. (hereinafter NM) warrants the product (other than software) manufactured by it to be free from defects in material and workmanship for a period of time of one year (except those parts normally considered as consumable/expendable components such as motor conditioning brushes). The warranty commences thirty (30) days from the date of shipment.

NM warrants those parts replaced under warranty for a period equal to the remaining warranty coverage of the original part.

NM's sole and exclusive obligation under this warranty provision shall be to repair, or at its sole option exchange defective products or the relevant part or component, but only if: (i) the Purchaser reports the defect to NM in writing and provides a description of the defective product and complete information about the manner of its discovery within ten (10) days of its discovery; (ii) NM has the opportunity to investigate the reported defect and to determine that the defect arises from faulty material, parts or workmanship; and (iii) the Purchaser returns the affected product to a location designated by NM. These provisions constitute the exclusive remedy of the Purchaser for product defects or any other claim of liability in connection with the purchase or use of NM products.

This warranty policy applies only to NM products purchased directly from NM or from an authorized NM distributor or representative.

This warranty shall not apply to (i) products repaired or altered by anyone other than those authorized by NM; (ii) products subjected to negligence, accidents or damage by circumstances beyond NM control; (iii) product subjected to improper operation or maintenance (i.e. operation not in accordance with NM Installation

Manuals and/or instructions) or for use other than the original purpose for which the product was designed to be used.

NM shall not in any event have obligations or liabilities to the Purchaser or any other party for loss of profits, loss of use or incidental, increased cost of operation or delays in operation, special or consequential damages, whether based on contract, tort (including negligence), strict liability, or any other theory or form of action, even if NM has been advised of the possibility thereof, arising out of or in connection with the manufacture, sale, delivery, use, repair or performance of the NM products. Without limiting the generality of the preceding sentence, NM shall not be liable to the Purchaser for personal injury or property damages.

Patent Information

Nanomotion products are covered under one or more of the following registered or applied for patents.

5,453,653; 5,616,980; 5,714,833; 111597; 5,640,063; 6,247,338; 6,244,076;
6,747,391; 6,661,153; 69838991.3; 6,384,515; 7,119,477; 7,075,211;
69932359.5; 1186063; 7,211,929; 69941195.5; 1577961; 4813708; 6,879,085;
6,979,936; 7,439,652; 7061158 ;1800356; 1800356; 1800356; 2007-533057
(pending); 2011-093431 (pending); 7,876,509; 10-2007-7009928 (pending);
200780019448.6 ; 7713361.9 (pending); 12/294,926 (pending); GB2008000004178
(pending); GB2009000003796 (pending); 12/398,216 (pending); GB2446428;
12/517,261 (pending); 08702695.1 (pending); 10-2009-7017629 (pending); 12/524,164
(pending); 12/581,194 (pending)

Revision History

Revision	Date	Details
00/A	July 2011	New release
NA	August 2012	Administrative change – added patent information to the front matter.

Table of Contents

1 GENERAL	8
1.1 General Handling Guidelines.....	8
1.2 Reference Documentation.....	8
2 INTRODUCTION	9
2.1 The EDGE Motor.....	9
2.2 EDGE Motor Features.....	9
3 MOTOR OPERATION	10
3.1 Operation Principle of the EDGE Motor.....	10
3.2 Driving Modes.....	10
4 MOTOR INSTALLATION	11
4.1 Mounting Base Design Considerations.....	11
4.2 Bonding the Driving Strip to the Stage.....	12
4.3 Mounting and Connecting the Motor.....	14
4.4 Operating the motor.....	16
5 MOTOR CONDITIONING	17
5.1 The Conditioning Procedure.....	17
6 TECHNICAL DATA	18
6.1 Motor Model for control simulations.....	18
6.2 Specifications.....	19
6.3 Dimensions.....	20
6.4 Thermal Envelope of Performance (EOP).....	20
7 MECHANICAL INTERFACES	24
7.1 EDGE Motor Layout.....	24
7.2 Mounting Base Layout.....	25
8 ELECTRO-MECHANICAL INTERFACE	26
9 CONTACT INFORMATION	27

9.1 Customer Service.....27
9.2 General Inquiries and Ordering27

List of Figures

Figure 1: Bonding the Ceramic Driving Strip 12
Figure 2: EDGE motor motion system mechanical parts overview 14
Figure 3: Connecting the Motor FPC to the FPC Electrical Interface (example of design used for EDGE MOTOR EVALUATION KIT)..... 15
Figure 4: Example of stage based on EDGE motor including ASIC EDGE driver and position encoder (EDGE MOTOR EVALUATION KIT stage)..... 16
Figure 5: Block Diagram of the Motor and Driver..... 18
Figure 6: EDGE motor Force vs. Velocity at different work regimes 21
Figure 7: Typical Motor Velocity vs. Command Operating in Standard Driving Mode 23
Figure 8: Typical Motor Velocity vs. Command Operating in Linear Driving Mode 23
Figure 9: EDGE motor mechanical layout 24
Figure 10: EDGE motor mounting base requirements..... 25
Figure 11: EDGE motor electro-mechanical interface..... 26

List of Abbreviations

ASIC	Application Specific Integrated Circuit Refers specifically to Nanomotion Controller Driver chip.
AC	Alternating Current
DC	Direct Current
ICD	Interface Controlled Document
IPA	Isopropyl Alcohol used for cleaning
PCB	Printed circuit board

1 General

The purpose of this user manual is to help the user to install and operate the EDGE Piezoceramic Motor.

This manual describes the physical dimensions, mechanical and electrical properties as well as the installation procedures of the motor.

This manual assumes that the user has a fundamental understanding of basic motion systems, as well as motion control concepts and applicable safety procedures.

1.1 General Handling Guidelines

- Do not remove the cover of the motor!
- Switch power on only when the motor is properly mounted
- Do not immerse the motor in any liquid or cleaning agent. Use only a clean cloth to wipe the motor
- Ensure that the motor, and especially the "finger tip", is not subjected to direct high mechanical shock
- Follow the installation instructions provided in this manual when mounting the motor. The EDGE motor is not user-serviceable. For any installation and mounting inquiries, please contact Nanomotion

1.2 Reference Documentation

- Nanomotion ASIC NM8SiP user manual , D/N: ASIC458000
- XCD EDGE Driver-Controller, D/N: XCDH458001.
- EDGE Driver User Manual, D/N: EDGE458003
- EDGE INTERFACE DRAWING, D/N: EDGE458101

2 Introduction

2.1 The EDGE Motor

The EDGE motor is the smallest industrial motor of its kind available in the marketplace today. Providing unlimited linear or rotary motion, the EDGE motor offers extensive opportunities in applications that suit a wide range of industries. The EDGE motor works with a uniquely designed, compact ASIC-based driver.

The EDGE motor can be easily integrated with most types of bearing structures and it is ideal for mass production applications.

2.2 EDGE Motor Features

- Compact size
- Lightweight
- High durability for demanding applications
- Low voltage
- Excellent move and settle characteristics
- Suitable for linear or rotary applications
- ASIC drive and control:
 - Standard Driving Mode
 - Linear Driving Mode
- Wide dynamic velocity range
- Inherent brake at power off
- High resolution
- Silent

3 Motor Operation

3.1 Operation Principle of the EDGE Motor

The Piezoelectric effect in piezo materials converts an electrical field into mechanical strain. Under special electrical excitation drive and specific geometry of Nanomotion motors, longitudinal extension and transverse bending oscillation modes are excited simultaneously at a single frequency. The simultaneous excitation of the longitudinal extension mode and the transverse bending mode creates a small elliptical trajectory of the ceramic tip, thus achieving the dual mode standing wave motor patented by Nanomotion. By coupling the ceramic tip to a precision stage, a resultant driving force is exerted on the stage, causing stage movement. The periodic nature of the driving force at frequencies much higher than the mechanical resonance of the stage allows continuous smooth motion for unlimited travel, while maintaining high resolution and positioning accuracy typical of piezoelectric devices. Travel can be linear or rotary, depending on the coupling mechanism.

3.2 Driving Modes

The EDGE motor can be driven by a custom NM ASIC driver, or alternatively by an XCD EDGE Driver-Controller (refer to section 1.2 for Reference Documentation). The ASIC Driver can drive the motor in two driving modes:

- **Standard Driving Mode** – standard motor operation mode. In this mode the motor is motionless up to approximately $\pm 1.5V$ command (Dead Band). Nanomotion motion algorithm enables smooth motion as well as micron-level displacement. This drive mode is the default mode for open / close-loop.
- **Linear Driving Mode** – this mode facilitates a linear response of the motor from 0 (zero) command level. This mode is recommended for scanning applications and micron-level displacement. The Linear Mode drive is preferable for perfect servo tracking and/or very low ripple constant velocity.

4 Motor Installation

This chapter provides detailed information about bonding the Ceramic Driving Strip and mounting and connecting the EDGE motor before operation.

To ensure peak motor performance, use of the Ceramic Driving Strip provided by Nanomotion is recommended. The Ceramic Driving Strip is specifically designed to work with Nanomotion's EDGE motor. Substituting this Strip with any other material might reduce motor performance or damage the motor and will void product warranty.

4.1 Mounting Base Design Considerations

Refer to chapter 7 for motor and mounting base drawings - note that mounting base dimensions refer to the front surface of the Ceramic Driving Strip. The mounting base should be perpendicular to the Ceramic Driving Strip.

Both screws securing the motor to the mounting surface are inserted from the top of the motor. In multi axis application make sure that any protrusion of the screws does not interfere with motion on another axis.

IMPORTANT:

- **The mounting base, the stage and the method used for mounting should be designed for maximum mechanical rigidity and stiffness $\geq 5 \text{ N}/\mu\text{m}$.**
- **The ceramic strip surface should move parallel to the motion. The maximum allowable run-out of the strip should not exceed $\pm 0.03\text{mm}$ (chapter 7)**

4.2 Bonding the Driving Strip to the Stage

Bond the Ceramic Driving Strip to the stage surface according to the following steps:

- a. Clean the bonding area of the stage, using a suitable agent such as Acetone, IPA or Ethanol
- b. Remove the Acrylic adhesive Tape backing paper from the Ceramic Driving Strip
- c. Attach the Ceramic Driving Strip to the previously cleaned stage area (see Figure 1), making sure no air bubbles are trapped between the stage and the ceramic strip.

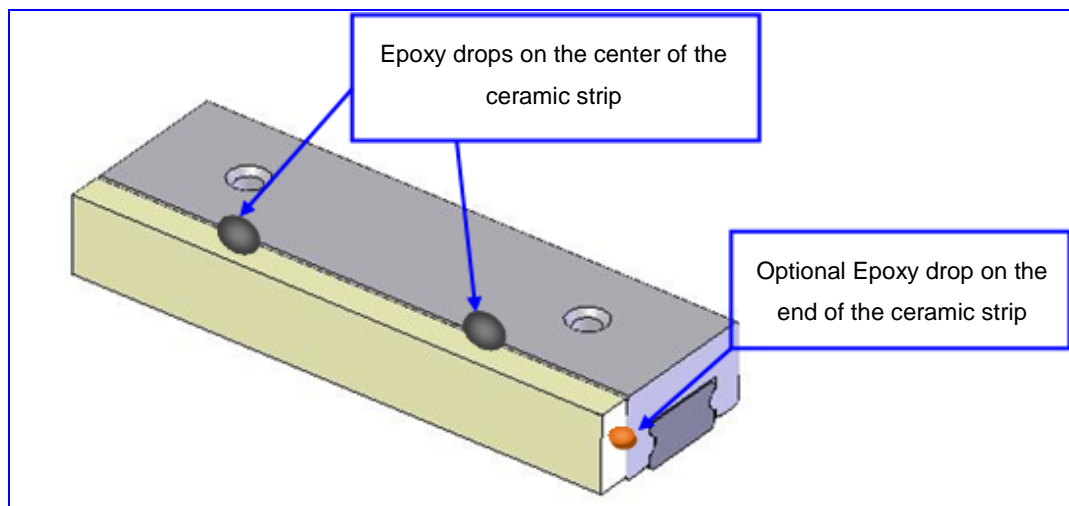

Figure 1: Bonding the Ceramic Driving Strip

- d. Verify that there is a maximum gap of 0.5mm between the lower edge of the Ceramic Driving Strip and the motor mounting surface (refer to chapter 7) to assure enough clearance for the motor tip.
- e. Apply two drops of Epoxy adhesive on the center of the Ceramic Driving Strip surface, about 5-10 mm apart. For short strips up to 10mm, a single drop can be applied on each end of the Ceramic Driving Strip (see Figure 1). The Epoxy must bond the strip to the slide. Recommended adhesive: 3M™ 2216 Epoxy or compatible.

- f. Allow the required time period for curing, according to the epoxy manufacturer's specifications.

IMPORTANT:

- **Ensure that the epoxy is in contact with the surfaces of both the strip and slide, but that it does not flow over the Ceramic Driving Strip front surface or over the upper working surface of the slide.**

4.3 Mounting and Connecting the Motor

In order to mount the motor against the moving slide (see Figure 2 and chapter 7) perform the following steps:

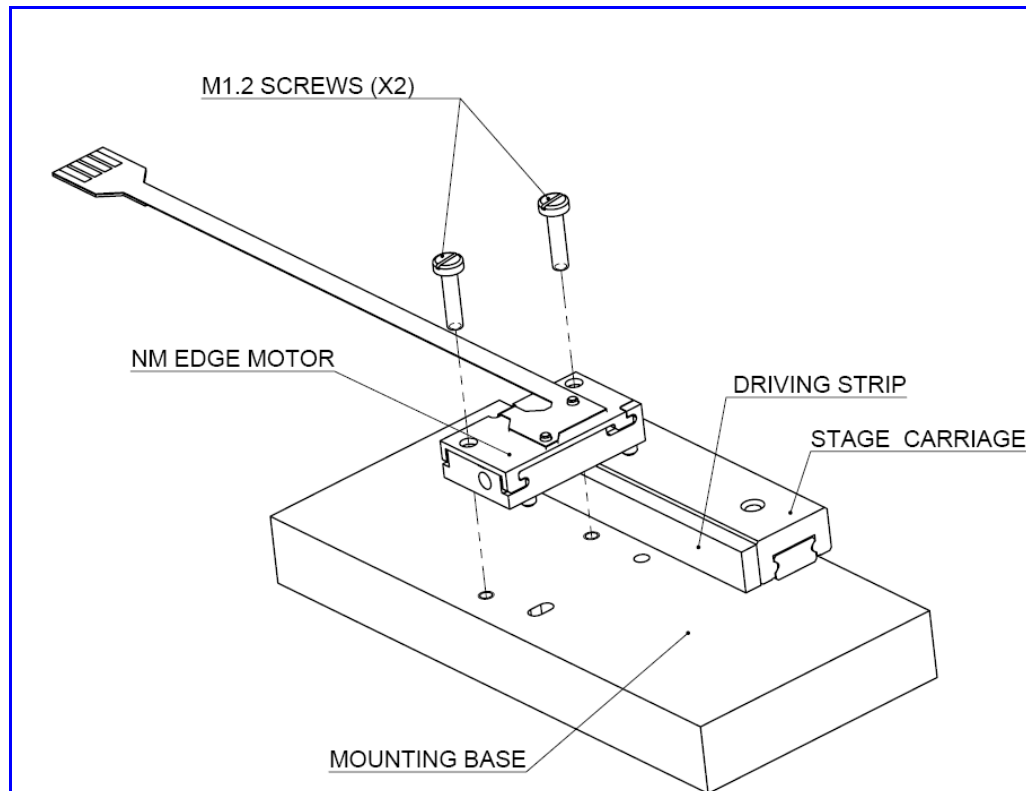

Figure 2: EDGE motor motion system mechanical parts overview

Assemble the slide with the ceramic strip upon the mounting plate. Make sure the slide position is according to Figure 10. The slide should be perpendicular to the holes and at the correct distance to enable proper mounting of the motor. This can be achieved by designing an alignment feature in the base plate or by using a jig which fits to the motor pin holes in the base.

- a. Place the motor “finger tip” against the ceramic plate and gently press the motor toward the ceramic plate until the motor pins can be inserted into the corresponding holes in the base. The motor is now correctly positioned.
- b. Insert two M1.2 screws into their corresponding holes on the motor and tighten them to a torque of 10-30 mNm. The motor is now

properly secured in its place. For applications which are exposed to external vibrations it is recommended using a bonding material such as *LOCTITE™ 242* to secure the screws.

- c. Connect the motor's FPC to the motor interface connector (see chapter 8 for Electro-Mechanical Interface details), located on the user's PCB. PCB and FPC design may change for different applications.

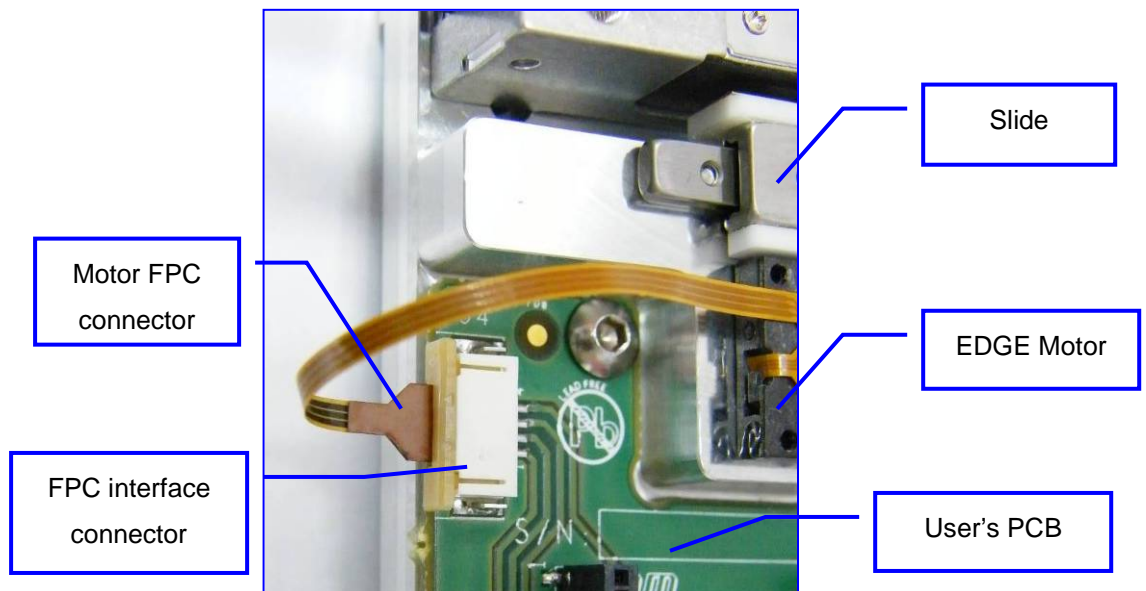

Figure 3: Connecting the Motor FPC to the FPC Electrical Interface (example of design used for EDGE MOTOR EVALUATION KIT)



Figure 4: Example of stage based on EDGE motor including ASIC EDGE driver and position encoder (EDGE MOTOR EVALUATION KIT stage).

4.4 Operating the motor

1. Connect the power supply and the communication line to the ASIC board. The communication line may be either an IIC line or an analogue command depending on the specific application¹. For specific applications, please ask Nanomotion for SW ICD.
2. Choose the driving mode (see section 3.2). The motor is now ready for Conditioning (see chapter 5).
3. For operating in close-loop, install an encoder and connect a controller to the motor driver.

Note – the NM ASIC driver can work either as a driver or as a controller-driver¹. For other drive and control configurations please contact Nanomotion.

¹ Please refer to the ASIC and the EDGE driver user manuals (see chapter 1.2)

5 Motor Conditioning

The EDGE motor must be conditioned before operating to stabilize the motor's dynamic performance, reduce wear rate and increase the lifetime of the system. Conditioning should be performed any time the motor is remounted on the stage.

5.1 The Conditioning Procedure

In order to condition the motor, perform the following steps:

- a. Conditioning is optimally performed in close loop.
- b. Conditioning must cover the entire expected travel distance on the Ceramic Driving Strip with additional margins.
- c. Set the driver to Standard Driving Mode (see Section 3.2).
- d. Run the stage repetitively from point to point in closed loop under the following conditions.
 1. Velocity – 70~80 mm/s.
 2. Acceleration/Deceleration – up to 2 m/s²
 3. Duty cycle – 50%. This means that the dwell time (the driver is disabled) should be the same as the move time (the driver is enabled).
 4. Conditioning duration: >30 minutes. For applications where control performance is not too demanding 10-15 min. conditioning is sufficient.
- e. When the conditioning is completed, carefully wipe the Ceramic Driving Strip surface with a Q-Tip soaked with IPA, without dismounting the motor. Run the motor for additional 1 min.
- f. The motor is now ready for operation.

6 Technical Data

6.1 Motor Model for control simulations

The EDGE motor moving a slide in a given direction can be modeled as a linear system driven by a DC motor by a voltage amplifier, as illustrated in Figure 5.

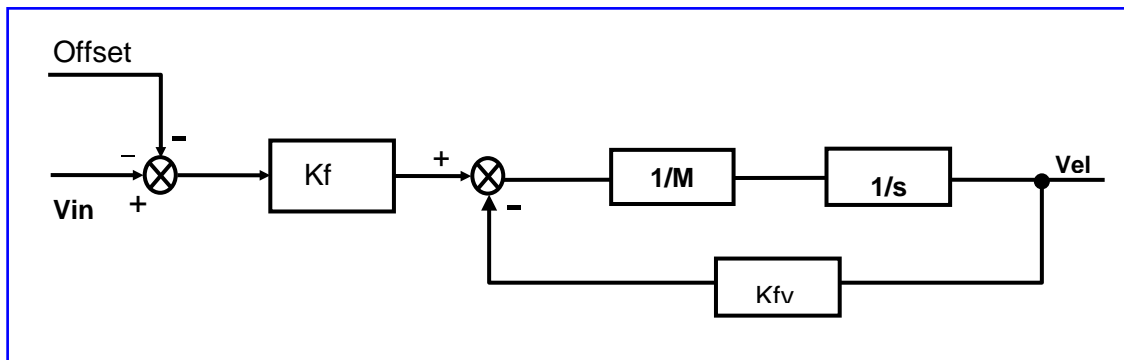

Figure 5: Block Diagram of the Motor and Driver

V_{in}	- Command to the driver ($0V \leq V_{in} \leq 10V$)
K_f	- Force constant [N/V]
Offset(*)	- Starting voltage [V]
K_{fv}	- Velocity damping factor (similar to back EMF) [N•s/m]
Vel	- Motor velocity [m/s]
M	- Moving mass [kg]
s	- Laplace variable [1/s]

(*) The diagram refers to both standard and linear modes. In linear drive mode Offset is designed to be zero.

6.2 Specifications

Performance Specifications		
Property	Unit	Value
Maximum Velocity	mm/s	>150
Max Dynamic Stall Force	mN	>300
Static Holding Force	mN	>290
Static Stiffness	N/ μ m	0.06 to 0.09
Preload on Stage	N	1.55 to 1.95
Kf	mN /[V]	30 to 50
Kfv	N s/m	1.0 to 2.7
Offset (Dead Band) In standard drive mode	[V]	1.0 to 3.5
Attainable Resolution	μ m	0.5 ^(*)
Nominal Lifetime	hr	20000 ^(*)
Electrical Specifications		
Property	Unit	Value
Motor Voltage at max command	V AC	8.5 to 11
Motor Current at max command	mA AC	130 ^(*)
Motor Power Consumption at max command	mW	400 to 750
Motor Capacitance (between Phase and COMMON)	nF	9.5 ^(*)
Environmental Specifications		
Property	Unit	Value
Ambient Operating Temperature	$^{\circ}$ C	-10 to 60 Standard
	$^{\circ}$ C	-45 to 71 Extended ^(**)
Storage Temperature	$^{\circ}$ C	-55 to 85
Humidity	0 to 80% non-condensing	

(*) Reference Value

(**) With NM Controller-Driver and algorithm

6.3 Dimensions

In the following table are the external dimensions of the motor. For detailed dimensions refer to section 7.1.

Physical Dimensions (Nominal Values)		
Property	Unit	Value
Length	mm	13.5
Width	mm	7.6
Height	mm	3.15
Weight	g	0.55

6.4 Thermal Envelope of Performance (EOP)

Motor operating temperature is a result of the balance between heat generation and heat dissipation.

- The heat generation depends on motor's work regime (driver command level).
- The heat is dissipated through the following heat transfer mechanisms: conduction, radiation and convection by air.

The heat dissipation mechanisms should be able to dissipate the heat generated in order to avoid overheating. The EOP gives the user the tools to assess the permitted operating conditions (for a set ambient temperature and dynamic performance) deriving the Duty Cycle and/or Maximal Continuous Operation that assures safe operation.

The user can operate the motor at a specific Duty Cycle for a periodic time interval which does not exceed the continuous time interval specified under "Maximal Continuous Operation".

For a given application at a given motion profile, the work regime is determined by the F-V curve given in Figure 6.

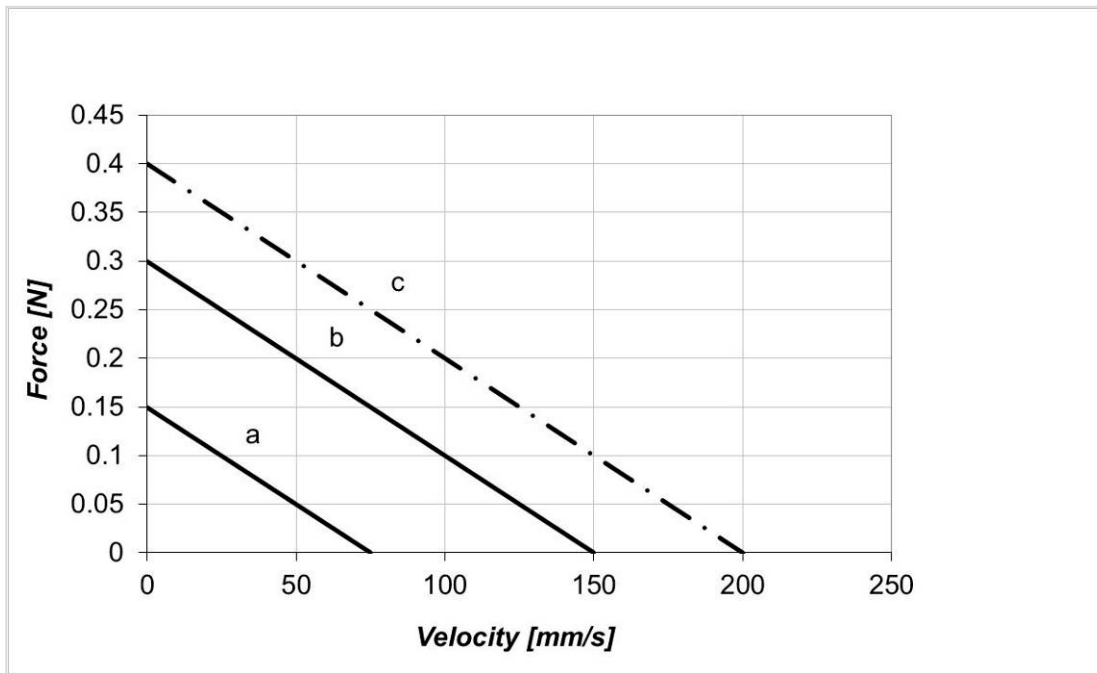

Figure 6: EDGE motor Force vs. Velocity at different work regimes²

Considering the above Figure 6, there is a corresponding limiting Duty Cycle and Maximum Continuous Operation time for each point on the motor force-velocity plane.

Table 1 and Figure 6 are designed to assist the user in determining the correct envelope of performance and avoid overheating and damaging the motor. Table 1 shows the limiting Duty Cycle and Maximum Continuous Operation time corresponding to the reference curves in Figure 6 for Standard and Linear drive mode when the motor is kept in an environment of up to 70°C.

² Curve “c” corresponds to performance beyond the maximum allowable velocity and is displayed for reference only.

Curve	Ambient Temperature <60 °C				
	Standard		Linear		
	Duty Cycle [%]	Maximum Continuous Operation [sec]	Duty Cycle [%]		Maximum Continuous Operation [sec]
			"Brake ON"	"Brake OFF"	
a	100	∞	100	100	∞
b					
c (*)					
Curve	Ambient Temperature 60-70 °C				
	Standard		Linear		
	Duty Cycle [%]	Maximum Continuous Operation [sec]	Duty Cycle [%]		Maximum Continuous Operation [sec]
			"Brake ON"	"Brake OFF"	
a	100	∞	100	100	∞
b	100	∞	80	30	60
c (*)	80	60	70	15	30

Table 1: EOP for EDGE Motor in Standard or Linear Driving Mode

(*) For reference only (see Footnote 2).

Notes:

- The Duty Cycle is the ratio of the operation time and the total work cycle (operation time + idle time).
- During the idle time, the driver can be DISABLED ("BRAKE ON") or set to 0 V command ("BRAKE OFF"). In **Linear Driving Mode** "BRAKE ON" and "BRAKE OFF" are not equivalent. Under "BRAKE OFF", although the driver is set to 0 V command, power is still consumed (and therefore, heat is generated) by the motor, effectively reducing the allowable Duty Cycle.

Figure 7 and Figure 8 display the minimal Motor Velocity vs. Driver command in Standard and Linear Modes correspondingly, for correlation between driver settings, motor performance, and EOP.

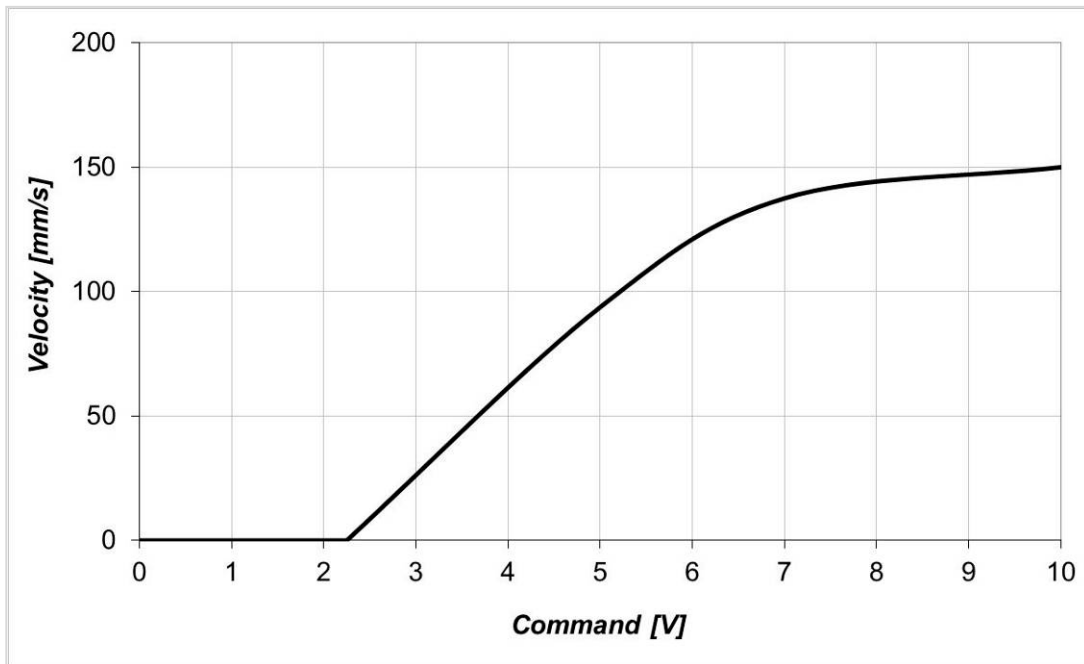

Figure 7: Typical Motor Velocity vs. Command Operating in Standard Driving Mode ³

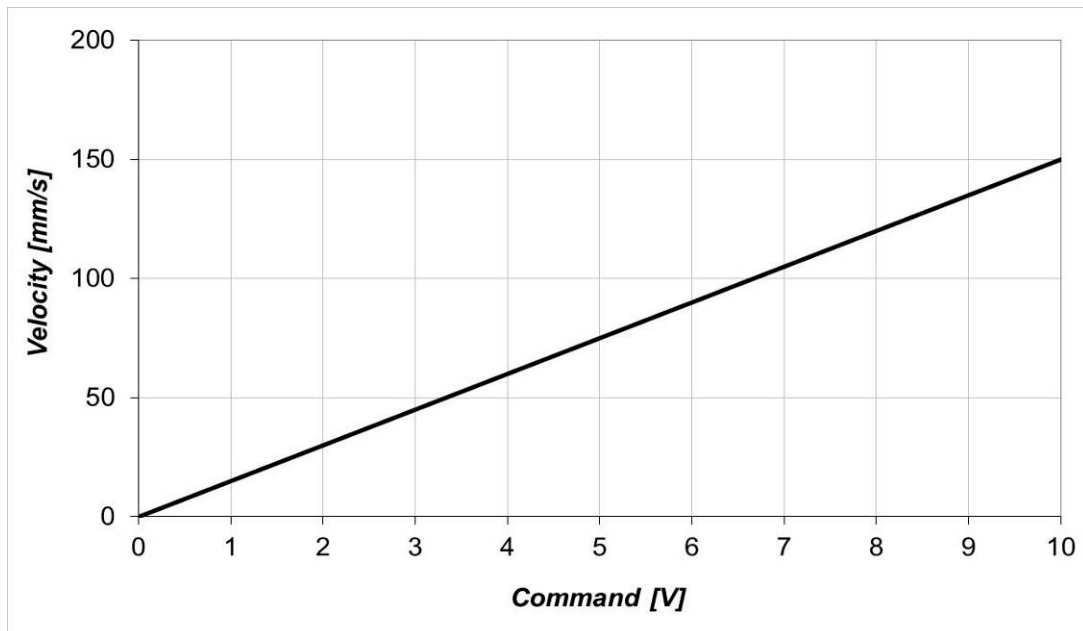

Figure 8: Typical Motor Velocity vs. Command Operating in Linear Driving Mode ³

³ The motor operates horizontally at room temperature and nominal conditions. It interfaces with the Ceramic Driving Strip (according to Nanomotion Specifications) and a cross-roller high quality slide.

7 Mechanical Interfaces

7.1 EDGE Motor Layout

Figure 9 shows the EDGE motor layout according to EDGE INTERFACE DRAWING, D/N EDGE458101.

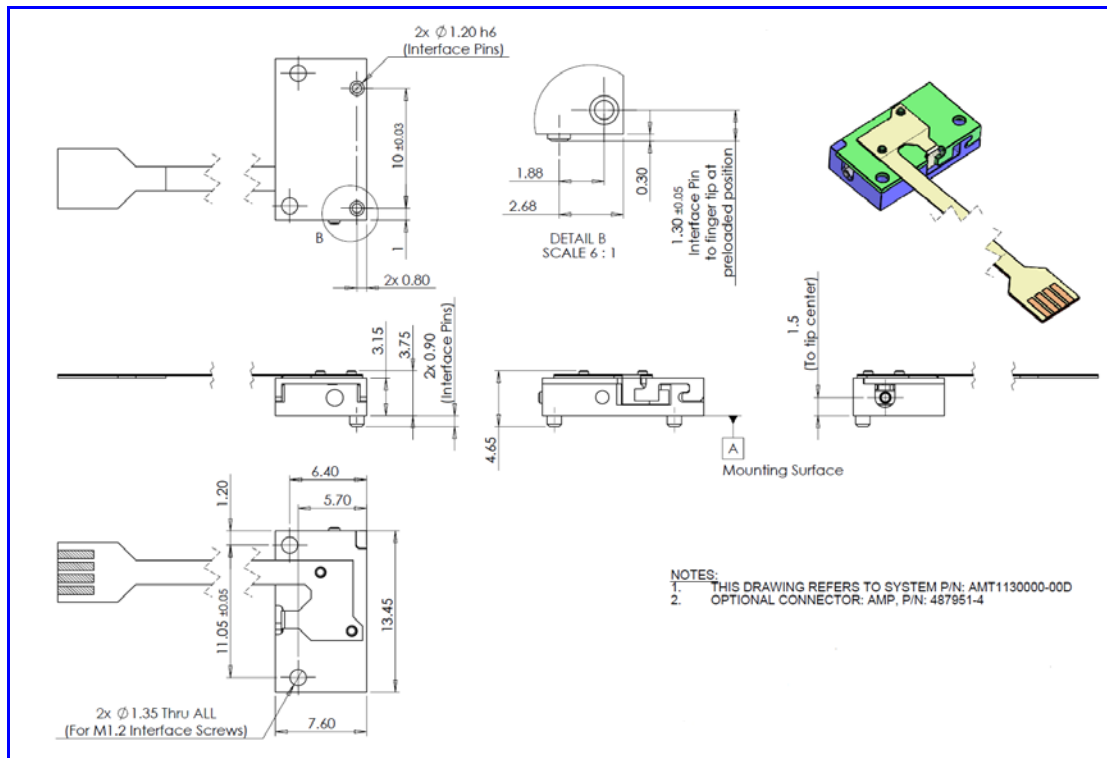

Figure 9: EDGE motor mechanical layout

Note:

The dimensions are in mm

Preloaded Position refers to Motor installed on a mounting based according to Section 7.2

7.2 Mounting Base Layout

Figure 10 shows the mounting base requirements for EDGE motors according to EDGE INTERFACE DRAWING, D/N EDGE458101

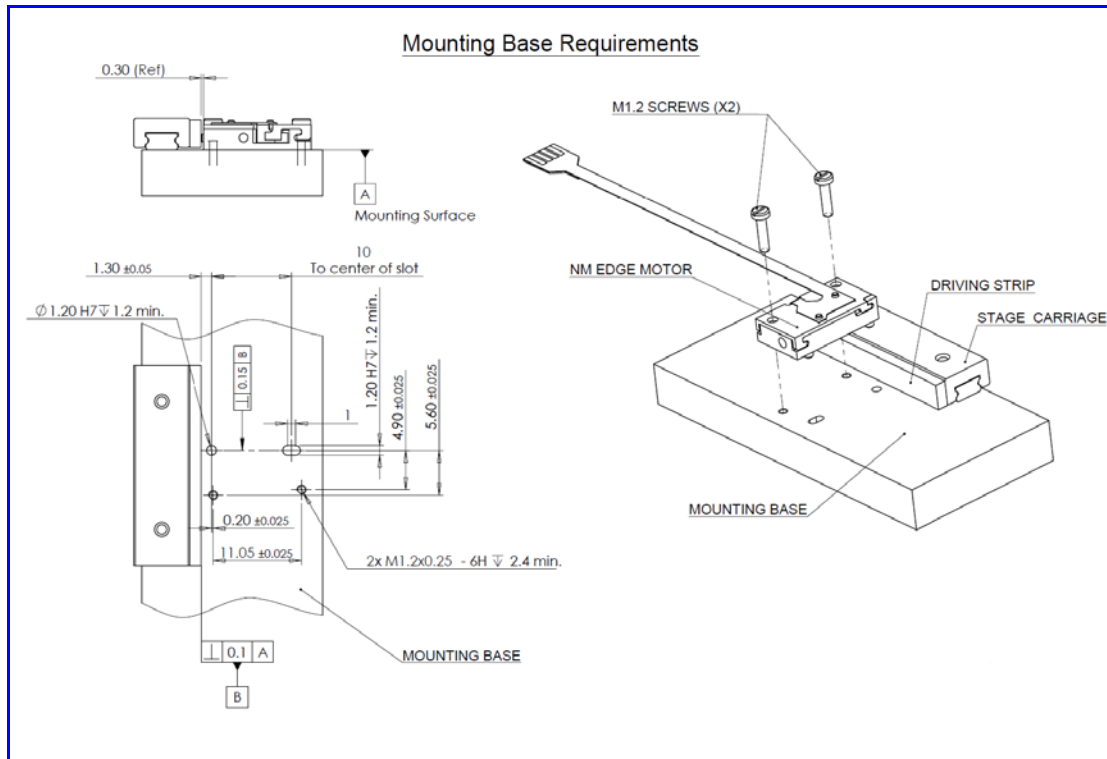

Figure 10: EDGE motor mounting base requirements

Note:

The dimensions are in mm

8 Electro-Mechanical Interface

Standard EDGE Motor FPC is designed to be used with a standard 1mm FPC Connector (for example AMP, P/N 487951-4). See EDGE INTERFACE DRAWING, D/N EDGE458101 for details and pinout. Note that the EDGE motor is also available with a custom FPC for specific OEM applications. Please contact Nanomotion Ltd. for advice.

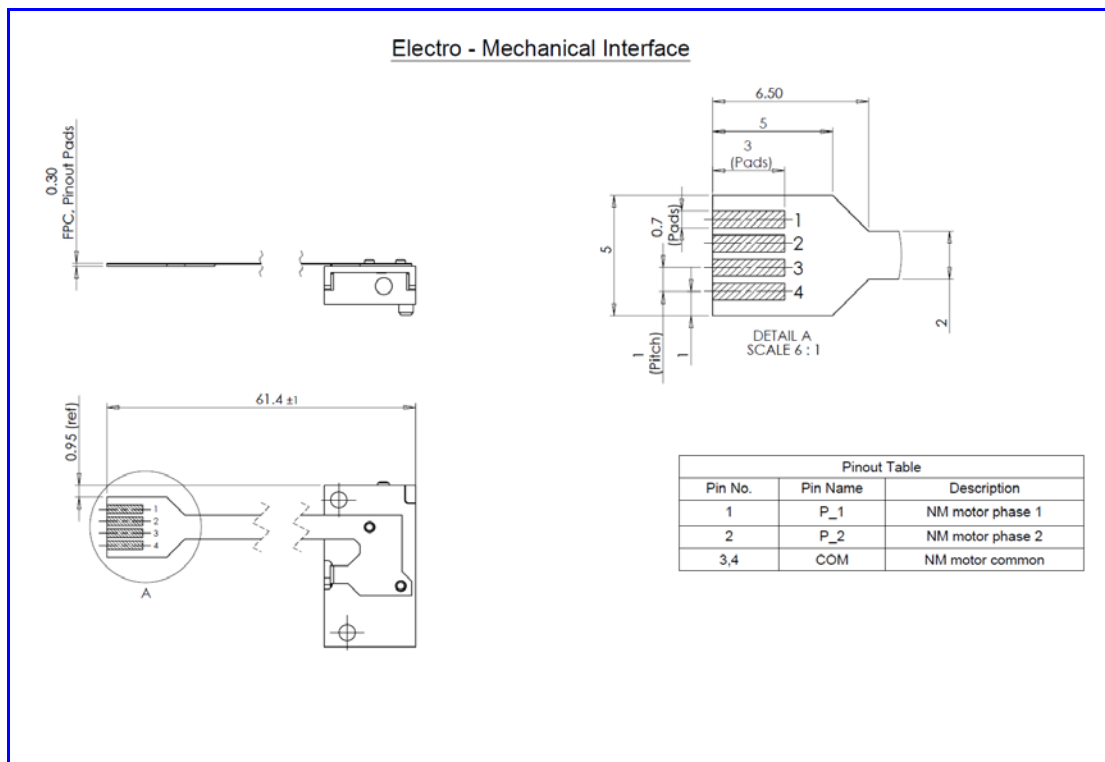

Figure 11: EDGE motor electro-mechanical interface

Note:

The dimensions are in mm

9 Contact Information

9.1 Customer Service

Contact your local distributor or email Nanomotion Ltd. Technical Support Department at techsupport@nanomotion.com, with detailed problem description.

9.2 General Inquiries and Ordering

Nanomotion Ltd. Headquarters

Nanomotion Ltd.

PO Box 623

Yokneam, Israel 20692

Tel: + 972-73-2498000

Fax: +972-73-2498099

Web site: www.nanomotion.com

Email: nano@nanomotion.com

Nanomotion Inc. (US) Headquarters

Nanomotion Inc

1 Comac Loop, Ste. 14B2

Ronkonkoma, NY 11779

Tel: (800)821-6266

Fax: (631)585-1947

Web site: www.nanomotion.com

Email: nanous@nanomotion.com