



A Johnson Electric Company

AB2 Driver User Manual

D/N: AB02458000-00 REV: C

August 29, 2012

Nanomotion Ltd. POB 623, Yokneam 20692, Israel

Tel: 972-73-2498000 Fax: 972-73-2498099

Web Site: www.nanomotion.com

E-mail: nano@nanomotion.com

Copyright

This document contains proprietary information of Nanomotion Ltd., and Nanomotion Inc., and may not be reproduced in any form without prior written consent from Nanomotion Ltd. and Nanomotion Inc.

No part of this document may be reproduced, translated, stored in a retrieval system or transmitted in any form and by any means, electronic, mechanical, photographic, photocopying, recording, or otherwise, without the written permission of Nanomotion Ltd.

Information provided in this document is subject to change without notice and does not represent a commitment on the part of Nanomotion Ltd.

Copyright 2003-2012, Yokneam, Israel. All rights reserved.

All products and company names are trademarks or registered trademarks of their respective holders.

Limited Warranty

Nanomotion Ltd. (hereinafter NM) warrants the product (other than software) manufactured by it to be free from defects in material and workmanship for a period of time of one year (except those parts normally considered as consumable/expendable components such as motor conditioning brushes). The warranty commences thirty (30) days from the date of shipment.

NM warrants those parts replaced under warranty for a period equal to the remaining warranty coverage of the original part.

NM's sole and exclusive obligation under this warranty provision shall be to repair, or at its sole option exchange defective products or the relevant part or component, but only if: (i) the Purchaser reports the defect to NM in writing and provides a description of the defective product and complete information about the manner of its discovery within ten (10) days of its discovery; (ii) NM has the opportunity to investigate the reported defect and determines that the defect arises from faulty material, parts or workmanship; and (iii) the Purchaser returns the affected product to a location designated by NM. These provisions constitute the exclusive remedy of the Purchaser for product defects or any other claim of liability in connection with the purchase or use of NM products.

This warranty policy applies only to NM products purchased directly from NM or from an authorized NM distributor or representative.

This warranty shall not apply to (i) products repaired or altered by anyone other than those authorized by NM; (ii) products subjected to negligence, accidents or damage by circumstances beyond NM control; (iii) product subjected to improper operation or maintenance (i.e. operation not in accordance with NM Installation Manuals and/or instructions) or for use other than the original purpose for which the product was designed to be used.

NM shall not in any event have obligations or liabilities to the Purchaser or any other party for loss of profits, loss of use or incidental, increased cost of operation or delays in operation, special or consequential damages, whether based on contract, tort (including negligence), strict liability, or any other theory or form of action, even if NM has been advised of the possibility thereof, arising out of or in connection with the manufacture, sale, delivery, use, repair or performance of the NM products. Without limiting the generality of the preceding sentence, NM shall not be liable to the Purchaser for personal injury or property damages.

Patent Information

Nanomotion products are covered under one or more of the following registered or applied for patents.

5,453,653; 5,616,980; 5,714,833; 111597; 5,640,063; 6,247,338; 6,244,076;
6,747,391; 6,661,153; 69838991.3; 6,384,515; 7,119,477; 7,075,211;
69932359.5; 1186063; 7,211,929; 69941195.5; 1577961; 4813708; 6,879,085;
6,979,936; 7,439,652; 7061158 ; 1800356; 1800356; 1800356; 2007-533057
(pending); 2011-093431 (pending); 7,876,509; 10-2007-7009928 (pending);
200780019448.6 ; 7713361.9 (pending); 12/294,926 (pending);
GB2008000004178 (pending); GB2009000003796 (pending); 12/398,216
(pending); GB2446428; 12/517,261 (pending); 08702695.1 (pending); 10-2009-
7017629 (pending); 12/524,164 (pending); 12/581,194 (pending)

Revision History

ECO	Revision	Release date	Details
NA	NA	Aug. 2012	Administrative change – added patent information section in front matter.

CE Compliance

This product was tested for Electrical Safety and Electromagnetic Compatibility.

It conforms with EMC Directive 89/336/EEC, Article 7(1); with FCC 47 CFR part 15 subpart B; and with LV directive 73/23/EC, Article 5 and satisfies the requirements of the following standards:

EN 61800-3:1996 + A11: 2000 for second environment.

EN 61000-3-2:2000, EN 61000-3-3:1995 + A1: 2001.

FCC 47 CFR: 2002 part 15, subpart B.

EN 61010 – 1:2001.

Table of Contents	
1 AB2 DESCRIPTION	10
1.1 General	10
1.2 Main Features	10
1.3 Operating Principles	11
2 CONNECTIONS AND I/O SETTINGS	13
2.1 Front Panel Description	13
2.1.1 Front Panel Connectors	14
2.1.2 Front Panel LED Indicators	14
2.2 Motion Control Interfaces	15
2.2.1 Analog Controller Connection	15
2.2.2 Joystick Connection	18
2.3 Cable Connections	19
2.3.1 Shielding	19
2.4 Motor Connections	19
2.4.1 Motor Cable Length	20
2.5 Opto-isolated Inputs	20
2.5.1 Voltage Source Configuration	21
2.6 Fault Output	22
2.7 Before Operating the Motor	22
3 THERMAL ENVELOPE OF PERFORMANCE (EOP)	23
3.1 Description	23
3.2 Stage Heat Dissipation Consideration	23
3.3 Thermal EOP for HR Motor Driven by AB1A, AB2, AB4 Drivers	24
3.3.1 An Example for Defining the EOP for AB2 Driver in Vacuum Environment	26
4 AB2 OPERATION	27
4.1 Operation Modes	27
4.1.1 Velocity (AC) Mode Operation	27
4.1.2 Step Mode operation	27
4.1.2.1 Enabling the Step Mode	27
4.1.3 Gate Mode Operation	27
4.1.3.1 Enabling the Gate Mode	28
4.1.4 DC Mode Operation	28
4.1.4.1 Enabling the DC Mode	28
4.1.4.2 DC mode EOP	29
5 SPECIFICATIONS	30
5.1 Parameters and Conditions	30

5.2	AB2 Layout.....	32
5.3	AB2 Pin Arrangement.....	33

List of Figures

Figure 1: AB2 Block Diagram	11
Figure 2: Schematic Diagram of the Output Stage in a Single Motor Configuration	12
Figure 3: AB2 Driver Box Front Panel	13
Figure 4: Differential Analog Input Connection	16
Figure 5: Non-Differential (single-ended) Analog Input Connection.....	17
Figure 6: Joystick Connection	18
Figure 7: Opto-Isolated Input Interface.....	20
Figure 8: Jumper 3 Configuration.....	21
Figure 1: Motor Velocity vs. Command.....	24
Figure 2: Motor Force vs. Velocity at the Various Work Regimes (a-g).....	25
Figure 9: Typical DC Mode Behaviour.....	28
Figure 10: AB2 Layout	32

List of Tables

Table 1: LED indicators.....	14
Table 1: EOP Table for HR Motors Driven by AB1A, AB2, AB4.....	25
Table 2: AB2 Power Consumption	30
Table 3: Electrical Specifications.....	30
Table 4: Physical Properties.....	30
Table 5: Environmental Conditions.....	30
Table 6: Analog Input Specifications	31
Table 7: DC Mode Specifications	31
Table 8: Control Terminal Pin Out.....	33
Table 9: Motor Output Port Pin Out.....	33
Table 10: I/O Port Pin Out.....	34

List of Abbreviations

A	Ampere
AC	Alternating Current
DC	Direct Current
LED	Light Emitting Diode
mA	Milliampere
mW	Milliwatt
TTL	Transistor-Transistor Logic
Vrms	Volts Root Mean Square

1 AB2 Description

1.1 General

The AB2 is a single-axis 24V amplifier box designed to drive up to 16 Nanomotion motor elements. Its main feature is the ability to drive motors in the “Piezo Actuator” mode of operation, or “DC Mode”, which enables the motors to achieve superior position resolution and accuracy in the range of a few nanometers on target. Currently, the motors driven by the AB2 are the HR types and the ST.

1.2 Main Features

- High precision (11 bits) control of the output power stage
- Drives up to two HR8 motors.
- Four operation modes: Velocity, Step, Gate and DC.
- Interface to an analog command
- Discrete inputs enabling feedback from external sources such as limit switches, emergency stop command, etc.
- Tricolor LED indicators
- Over Current, Over Voltage, and No Load protections
- Minimized sensitivity to cable lengthening
- Compact dimensions

1.3 Operating Principles

The AB2 Box consists of a single card (command source) that converts the input command signal into a corresponding PWM output signal. In this mode the output transformer-amplifier circuit converts the PWM output signal into a high voltage sine wave that drives the motor. The PWM controller is power-fed from an internal DC-to-DC converter that is fed from an external +24V power supply. The AB2 card consists of DC/DC converters that provide the voltages necessary to operate the amplifier circuit: +5V, $\pm 12V$. In addition, the card contains two indicators LED's and the external interface connectors for the CONTROL, MOTOR, and I/O signals.

Figure 1 illustrates a typical application of the AB2 Driver Box.

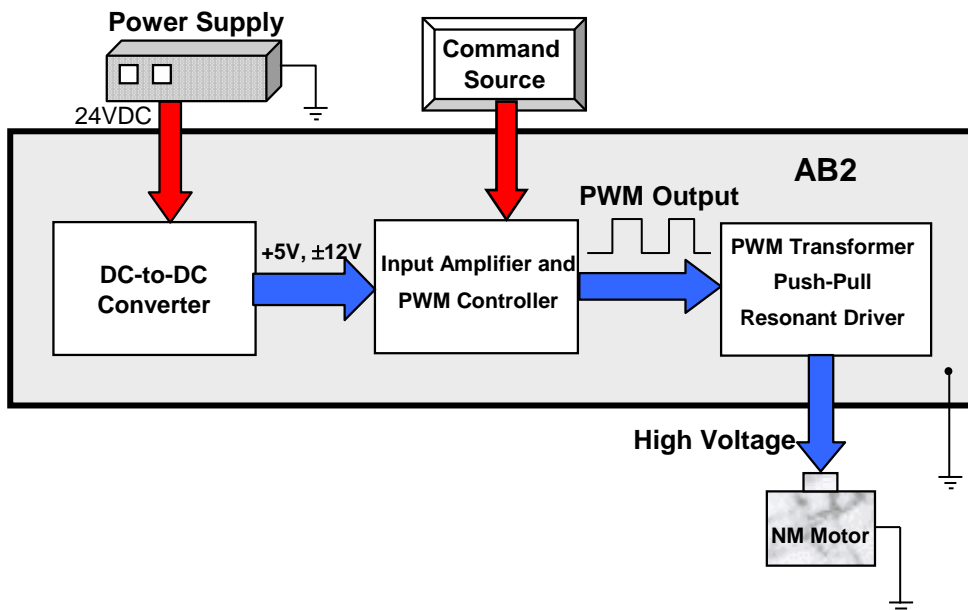

Figure 1: AB2 Block Diagram

This square wave from the PWM Controller is filtered through the serial inductance circuit and fed to the push-pull transformer circuit to produce a sine-wave high output voltage on the secondary coil of the transformer. The secondary coil and the motor capacitance serve as the LC resonance circuit.

The motor is a three-terminal component: "UP", "DOWN" and "COMMON." The voltage applied between the "UP" and "COMMON" terminals causes the motor to move in one direction; while voltage applied between the "DOWN" and "COMMON" terminals causes the motor to move in the opposite direction. Figure 2 is a schematic drawing of the power output.

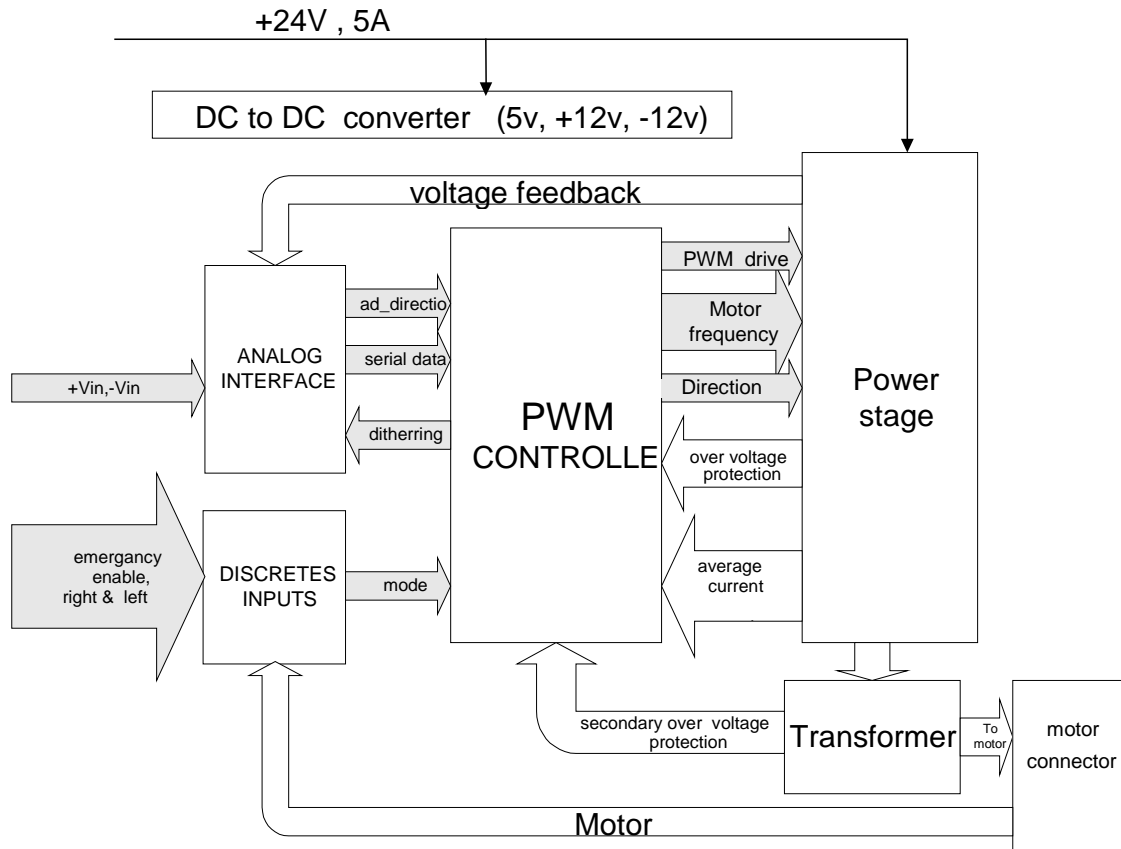

Figure 2: Schematic Diagram of the Output Stage in a Single Motor Configuration

2 Connections and I/O Settings

2.1 Front Panel Description

The AB2 front panel (see Figure 3) contains the following connectors and indicators:

- Control Terminal
- Motor Output port
- I/O port
- Enable/Fault Indicators
- Ground Screw
-
-



Figure 3: AB2 Driver Box Front Panel

2.1.1 Front Panel Connectors

Connector	Description
Control terminal	5-pin connector – Provides input from an external +24 VDC power supply (5A maximum). Provides direct control of the motor ENABLE signal. The primary voltage (+24V) is supplied from an external source.
I/O Port	D-type 25 pin connector female - Interfaces to the control source (joystick or controller)
Motor Out	D-type 9-pin connector male -Interfaces to the motor.

See also Table 9, Table 10 and Table 11

2.1.2 Front Panel LED Indicators

Table 1: LED indicators

	POWER	ENABLE
Vcc < 4.6V	Off	Off
Vcc > 4.6V; Motor not connected	Green	Off
Motor connected and disabled	Green	Orange
Motor enabled	Green	Green
Over Current / Over Voltage	Green	Red

2.2 Motion Control Interfaces

The AB2 Driver Box can receive the input signals either from a motion controller or from a joystick. The schematic diagrams of the motion controllers and joystick connections to the AB2 Driver Box are provided in following sections.



NOTE:

***The motor may be operated with minimum control signals applied to the Control Terminal:
+24V,GND POWER, +VIN, -VIN, ENABLE_IN.***

2.2.1 Analog Controller Connection

There are two options of an analog connection of a motion controller to the AB2 Driver Box:

- Differential connection (see Figure 4)
- Single-Ended Connection (see Figure 5)

The differential connection enhances noise immunity.

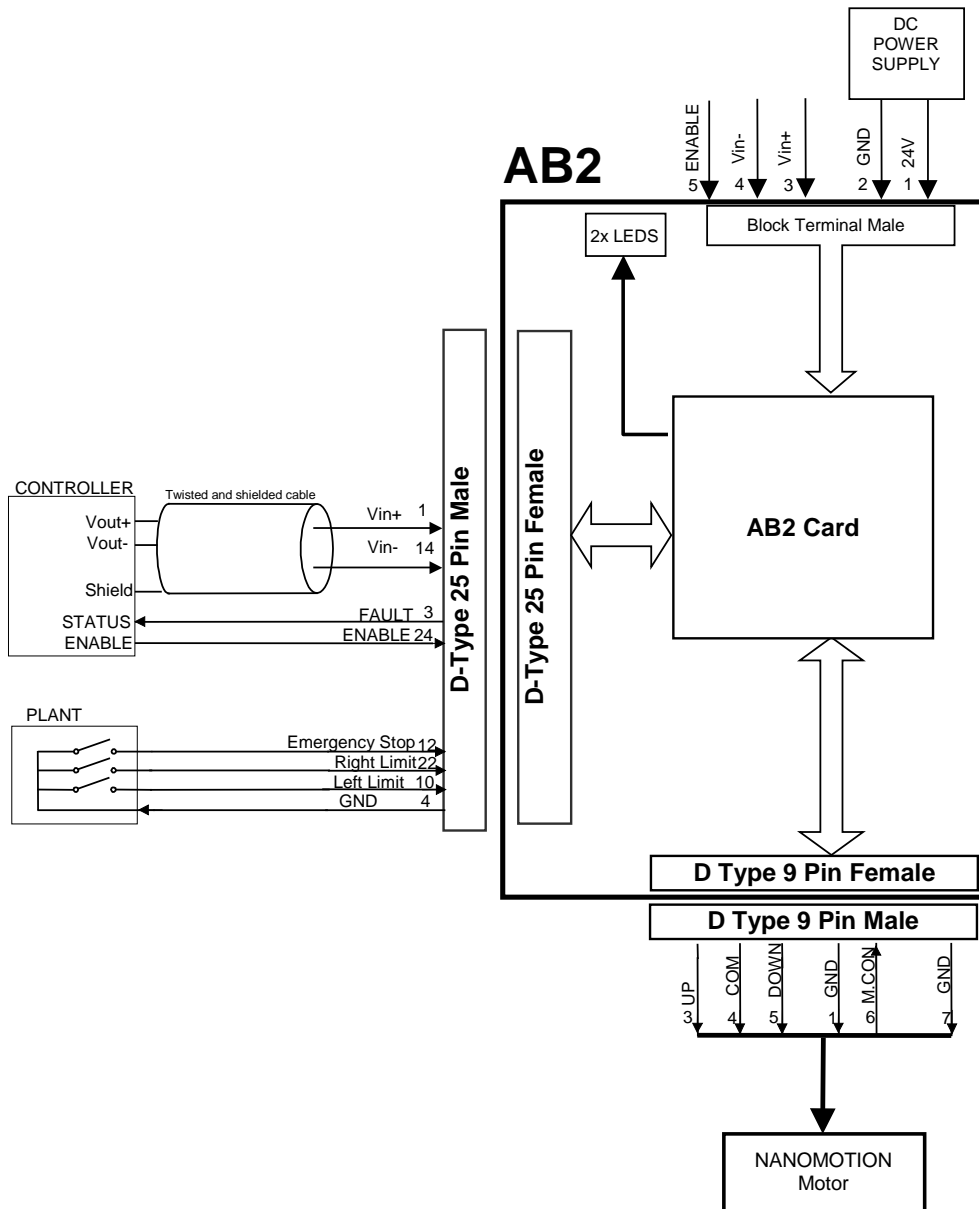

Figure 4: Differential Analog Input Connection

The other option of an analog controller connection is the single-ended connection.

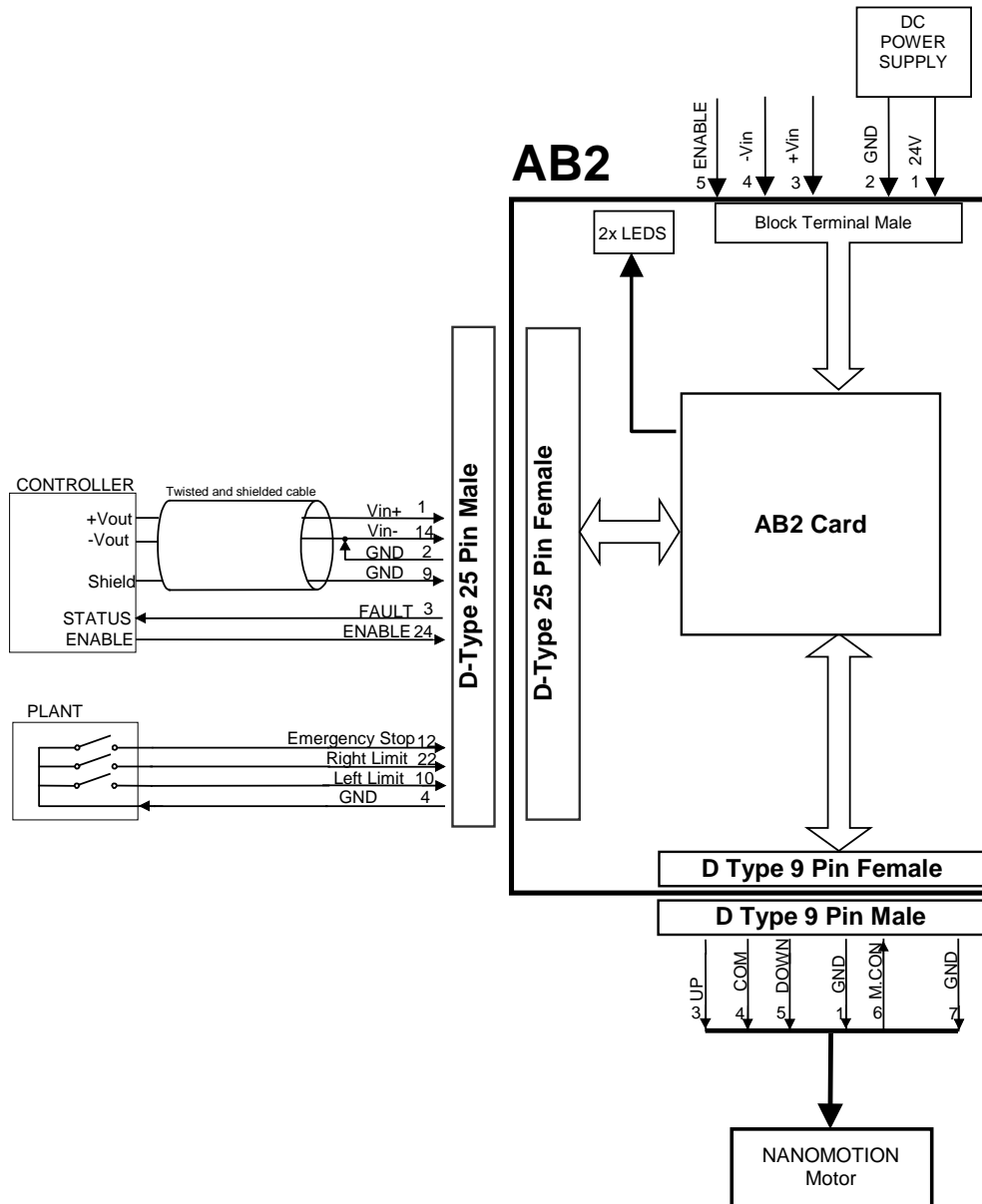

Figure 5: Non-Differential (single-ended) Analog Input Connection.

2.2.2 Joystick Connection

Using the joystick for supplying the command voltage to the AB2 Driver Box allows the user to manually drive the motor without using a motion controller.

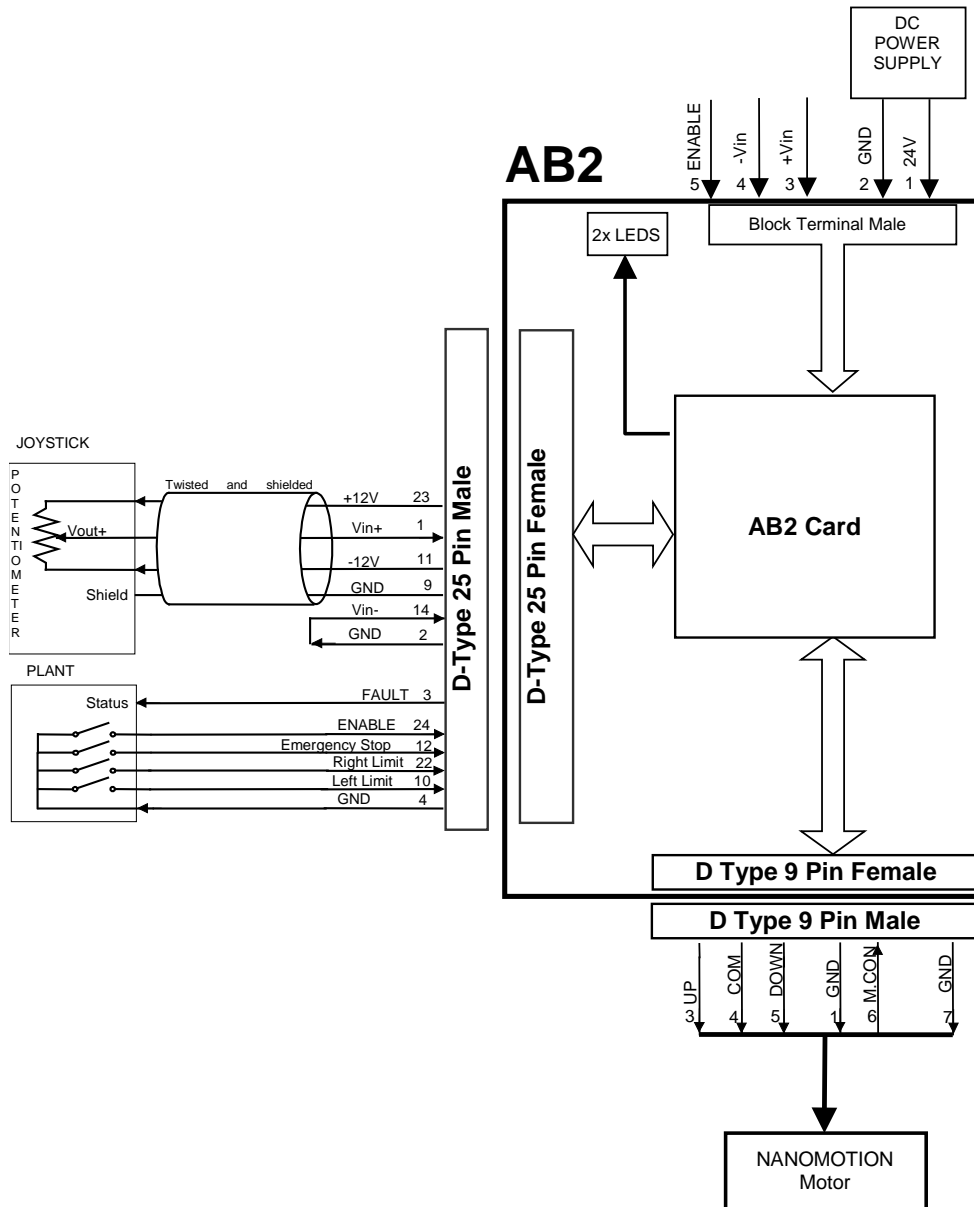

Figure 6: Joystick Connection

2.3 Cable Connections

Connect the following groups of cables together, isolating each of the signals:

- **POWER SUPPLIES** – use 22 AWG (or lower AWG) wires for the power supplies. For noisy surroundings, it is recommended to twist the ground line and the power line together.
- **ANALOG COMMAND** – a twisted shielded cable is recommended.
- **DISCRETE INPUTS** – These signals are not sensitive to noise and can be grouped together in the same harness with any of the other groups.

2.3.1 Shielding

Since the high motor voltage is induced on the cable shield, it is required to ground the shield on both sides. Both the driver card and the motor should be grounded to the infrastructure earth.

2.4 Motor Connections

The “Motor Connected” signal is available only at the motor connector, where it is shorted to ground (see Table 10). This ensures that unprotected motor pins will not be exposed to high voltage when the motor is not connected.

If more than one motor is connected to the AB2 Driver Box, use a suitable branch cable.

If the motor type or the number of motor elements is changed, consult Nanomotion for the appropriate driver configuration changes that may be required.

2.4.1 Motor Cable Length

The maximum allowed total cable length connecting the AB2 to the motor(s) is 20 meters for the HR types and 10 meters for the ST.

Use Nanomotion standard cables. Branching is possible to two and four identical motors. Branch cables must be of identical length, the sum of which not exceeding the allowed total cable length.



NOTE:

Nanomotion can guarantee proper driver and motor performance only when Nanomotion standard cables are used.

2.5 Opto-isolated Inputs

The following inputs are opto-isolated and are activated by shorting them to ground; See also Table 11:

- Powering
 - ◆ **Emergency Stop.** Disables the AB2 output.
 - ◆ **Enable_In.** Should be activated before the motor can be run.
- Mode Enabling
 - ◆ **Step_In.** Enables Step/Gate operation Modes.
 - ◆ **DC Mode.** Activates the DC mode of operation.
- Direction Restrictions
 - ◆ **Left SW.** Disables the motor motion to the left.
 - ◆ **Right SW.** Disables the motor motion to the right.

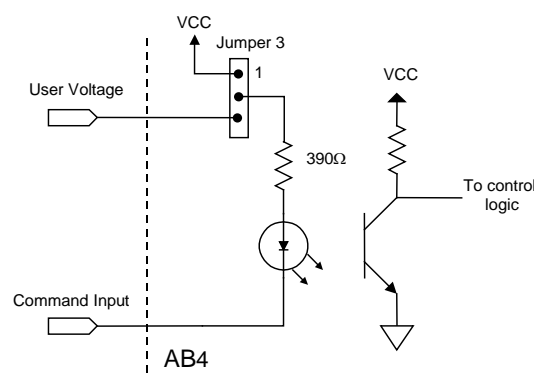

Figure 7: Opto-Isolated Input Interface

2.5.1 Voltage Source Configuration.

The opto-isolated input signals (2.2.1) are activated as short-to-ground. The voltage for the opto-isolated circuit (see Figure 8) is provided by either the internal +5V supply (default state) or an external voltage supply via pin 13 on the I/O Port connector. The input to be activated should be shorted to external voltage supply ground.

Configure jumper JP 1 on the AB2 card according to the voltage source:

- Pin 1 shorted to Pin 2, for an internal +5V source (default factory setting)
- Pin 2 shorted to Pin 3, for an external voltage source

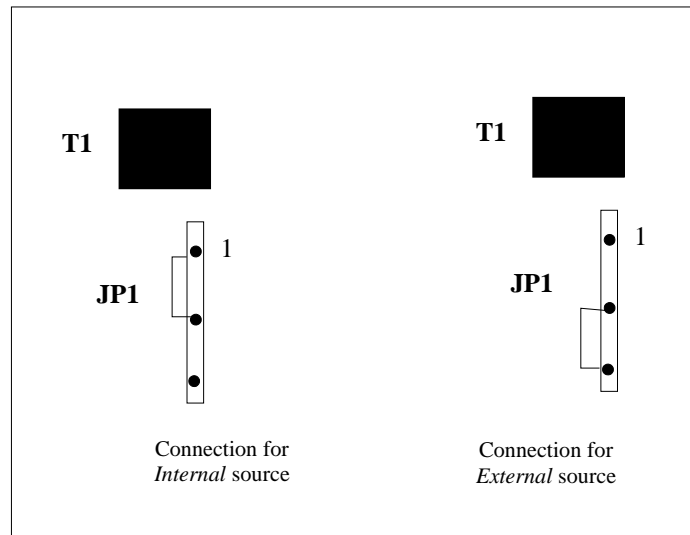

Figure 8: Jumper 3 Configuration



ATTENTION:

Do not short Pin 1 to Pin 3 on JP3. Doing so shorts the external power supply to the +5V supply! The input circuit is limited to sink up to 10 mA but not less than 3 mA.

2.6 Fault Output

The Fault Output follows open collector logic. When activated by shorting to ground it disables the motors under the following conditions:

- Over-current (8A)
- Over voltage
- The motor is not connected and the “Motor Connected” signal (section 2.4) is floating
- The AB2 is disabled or the Emergency Stop input is activated
- One of the Limit Switches is activated



NOTE:

The Fault output is capable of sinking a maximum of 20 mA, and is not protected from over current.

2.7 Before Operating the Motor

Before operating the AB2, verify the following:

- Jumper JP1 is set to the required mode of operation (see section 2.5.1)
- Mechanical screws lock all connectors
- The external power supply is capable of supplying the required power consumption of the AB2 (see Table 4)
- There is no command when switching the power to “ON”
- All motors are correctly mounted and preloaded.



ATTENTION:

- 1. The command should be limited according to the envelope of performance of the motor. Refer to the Motor User Manual.***
- 2. Driver should be grounded to infrastructure earth before operating.***

3 Thermal Envelope of Performance (EOP)

3.1 Description

Motor operating temperature is a result of the balance between heat generation and heat dissipation.

- The heat generation depends on motor's work regime (driver command level).
- The heat is dissipated through the following heat transfer mechanisms: conduction, radiation and convection (the convection mechanism is negligible in vacuum environment).

The heat dissipation mechanisms should be able to dissipate the heat generated in order to avoid overheating. The EOP gives the user the tools to assess the permitted operating conditions (for set ambient temperature and command, deriving the duty cycle and maximal continuous operation that assures safe operation).

The user can either operate the motor for an extended period of time at a specific duty cycle or alternatively, can operate the motor for a continuous time period specified under "Maximal Continuous Operation Time" (see graph and table in section 3.3). After the continuous operation is completed, the driver must be disabled to cool down the motor for 400 sec in air and for 700 sec in vacuum environment.

-  **Notes:**

- ▣ *The duty cycle is the ratio of the operation time and the total work cycle (operation time + idle time).*
- ▣ *Upon operating a motion system in vacuum, it is expected that the Coefficient of Friction of the bearing structure will increase. This may require changing the system operation point on the thermal EOP curves.*

3.2 Stage Heat Dissipation Consideration

The motor heat dissipation mechanism is by convection and radiation to the motor case, and by conduction through motor's 'finger tips'. Hence, the motor and the Ceramic Driving Strip bases, must both be thermally designed to dissipate 2W each (per motor's 'finger tip'), with maximum temperature rise of 15°C.

3.3 Thermal EOP for HR Motor Driven by AB1A, AB2, AB4 Drivers

Figure 9 illustrates motor velocity as a function of the applied driver command voltage. Allowing up to 30 mm/sec variations, use it as a reference and as a guideline for expected motor performance:

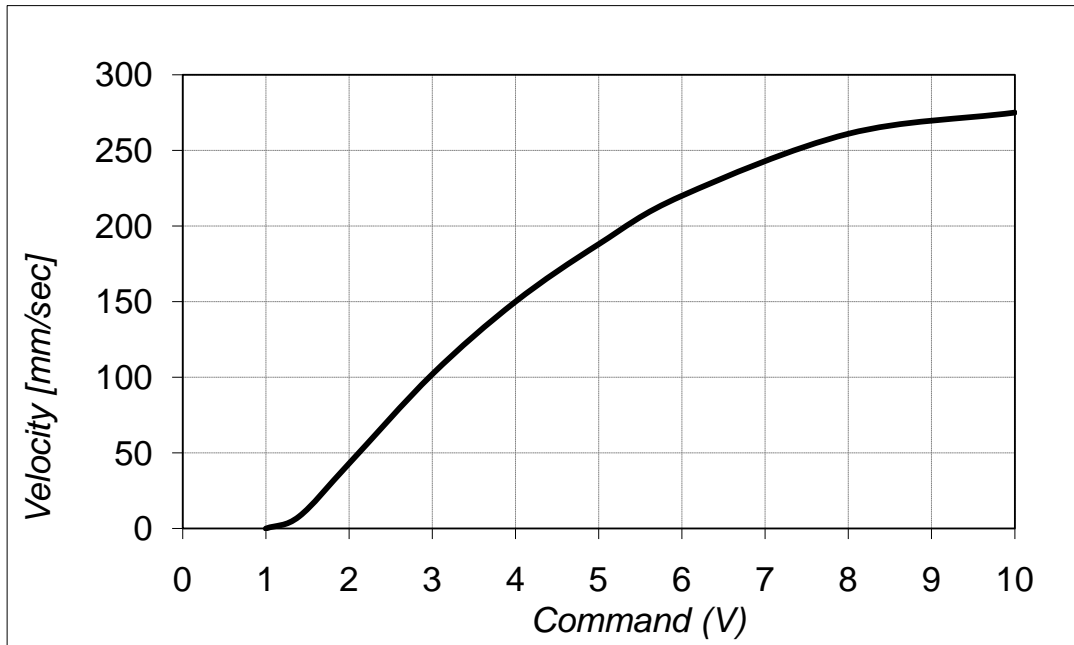

Figure 9: Motor Velocity vs. Command¹

Figure 10 and Table 2 are designed to help the user determining the correct envelope of performance and avoid overheating and damaging the motor.

¹ The motor operates horizontally at room temperature and low duty cycle (< 10%). It interfaces with the Ceramic Driving Strip (according to Nanomotion Specifications) and a cross-roller high quality slide.

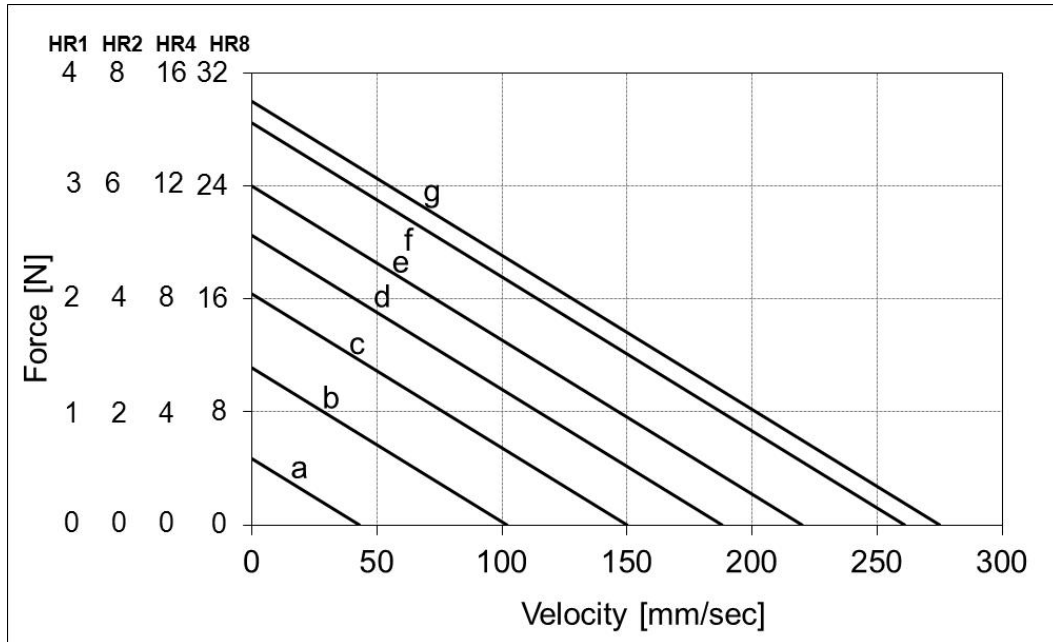

Figure 10: Motor Force vs. Velocity at the Various Work Regimes (a-g)

AB1A, AB2, AB4						
Curve	Air 25°C		Air 50°C		Vacuum	
	Duty Cycle [%]	Maximal Continuous Operation time [sec]	Duty Cycle [%]	Maximal Continuous Operation time [sec]	Duty Cycle [%]	Maximal Continuous Operation time [sec]
a	100	∞	100	∞	100	∞
b	100	∞	100	∞	44	184
c	100	∞	92	137	26	107
d	100	∞	62	93	17	72
e	78	87	47	70	13	55
f	56	62	33	50	9	39
g	50	56	30	45	8	35

Table 2: EOP Table for HR Motors Driven by AB1A, AB2, AB4

3.3.1 An Example for Defining the EOP for AB2 Driver in Vacuum Environment

An example for using the graph and table (Figure 10 and Table 2) for the AB2 driver and HR8 motor:

A vacuum application requires 10N at a velocity of 100mm/sec. The graph shows that this point of operation corresponds to the curve “d”.

The table shows that curve “d” and a vacuum environment require that a duty cycle of 17% will not be exceeded and the maximum continuous operation time is limited to 72 seconds.

4 AB2 Operation

4.1 Operation Modes

The AB2 can be operated in one of the following operation modes:

- **Velocity (AC) Mode**, in which the motor is driven continuously. This is the default mode.
- **Step Mode**, in which the driver output is turned OFF and ON at hardware, predefined intervals, thus driving the motor in discrete steps.
- **Gate Mode**, enables to drive the motor in low velocities in open loop by turning the driver output ON and OFF in time intervals defined by the user.
- **DC Mode**, in which the motor works as a piezo actuator, enabling accurate positioning of a few nanometers.

Both Enable_In and Motor_Connected inputs must be active for the four modes to operate.

4.1.1 Velocity (AC) Mode Operation

In this operation mode, the motor is driven continuously by applying the analog command voltage (± 10 V) using a relevant interface device (joystick or motion controller).

4.1.2 Step Mode operation

In this operation mode, the driver output to the motor is turned on and off for fixed time intervals defined in the hardware as follows:

- ON phase - 1/16 second
- OFF phase - 0.5 second

The amplitude of the output corresponds to the analog command input value and thus determines the speed of the motor.

4.1.2.1 Enabling the Step Mode

Enable the Step operation mode, by shorting pin 16 to the ground.

4.1.3 Gate Mode Operation

In Gate Mode, as opposed to Step Mode the pulse width and pulse frequency are user-defined. The driver output to the motor is turned on and off in time intervals defined by an external switching signal.

The amplitude of the output corresponds to the analog command input value and thus determines the speed of the motor.

The allowable parameter values for the external signal are as follows:

- Voltage levels: 0V-on; 5V-off. Open collector logic is also optional.
- Minimum pulse width: 50 μ sec.
- Maximum pulse frequency: 1 kHz.

4.1.3.1 Enabling the Gate Mode

Enable the Gate mode of operation by shorting pin 8 to the ground. Verify that pin 16 is not shorted to the ground at the same time. Once pin 8 is shorted, the driver is in Gate Mode. The external signal should now be conducted through pin 16.

4.1.4 DC Mode Operation

When operating in the DC mode, the driver enables the motor to converge to 10nm and less. The travel available in this mode is 300 nm from the point reached by the motor while operating in the regular Velocity (AC) mode.

As shown in Figure 11, the position is a linear function of the command voltage, with certain hysteresis; some asymmetry is normal and expected.

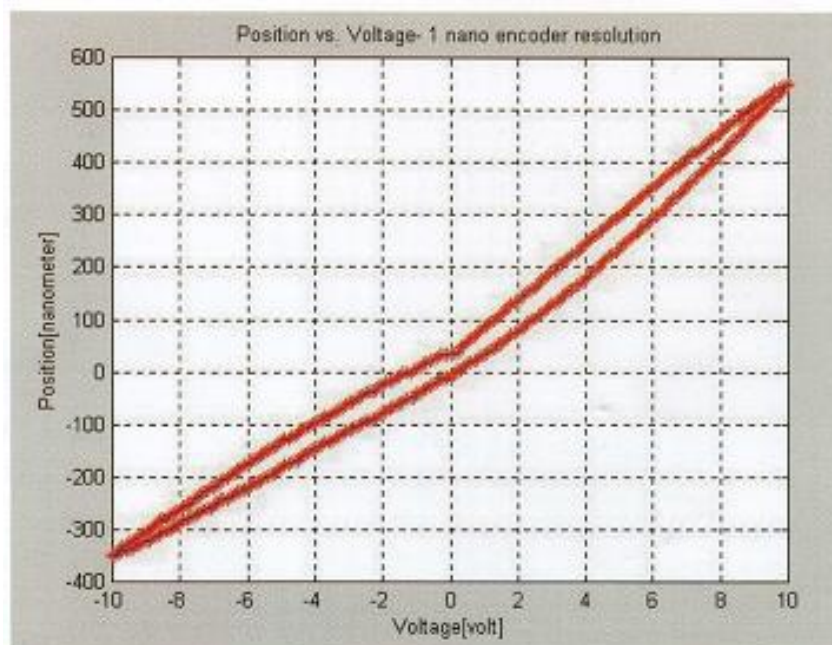

Figure 11: Typical DC Mode Behaviour

4.1.4.1 Enabling the DC Mode

Enable the DC mode of operation by shorting pin 21 to the ground.



Warning:

When switching between AC and DC modes, the command voltage should be less than 3V.

4.1.4.2DC mode EOP

When in DC mode, the driver's EOP (Envelope of performance) is limited. Exceeding it may result in damaging the driver. The following EOP should be maintained regardless of the type or number of motors driven.

Command [V]	Max continuous DC mode operation [min]	Max DC mode Duty cycle [%]
1-7	∞	100
8	12	40
9	6	25
10	4	17

5 Specifications

5.1 Parameters and Conditions

Table 3: AB2 Power Consumption

Power Input	+24 VDC \pm 5% (stabilized)
Max Motor Output	280 Vrms
Power Consumption without Load	+24 VDC/200 mA
Power Consumption with Max load	+24 VDC/5A

Table 4: Electrical Specifications

Supply Voltage	Current Consumption	Applicable When
	400 mA	HR1 is connected.
+24 VDC \pm 5%	800 mA	HR2 is connected.
	1500 mA	HR4 is connected.
	2800 mA	HR8 is connected.
	300 mA	ST is connected.

The required power supply value should be calculated by adding the total power consumption of all the motors that are connected to the AB2 power consumption without motor (+24 VDC/125 mA_{rms}) according to the following:

- $I = 125\text{mA} + n \cdot (\text{current consumption of a single motor})$
- $n = \text{Number of motors that are connected (n= 1/2/3/4)}$.

Table 5: Physical Properties

Weight	450g
---------------	------

Table 6: Environmental Conditions

Operating Temperature	0°C to 50°C
Storage Temperature	-40°C to 70°C

Operating Humidity	Up to 80% Non-condensing
--------------------	--------------------------

Table 7: Analog Input Specifications

Input voltage range:	$\pm 10V$
Input impedance:	10k Ω
Input low pass filter:	2.7 kHz

Table 8: DC Mode Specifications

Switch time between Velocity and DC modes:	1ms
Range:	$\pm 300nm$

5.2 AB2 Layout

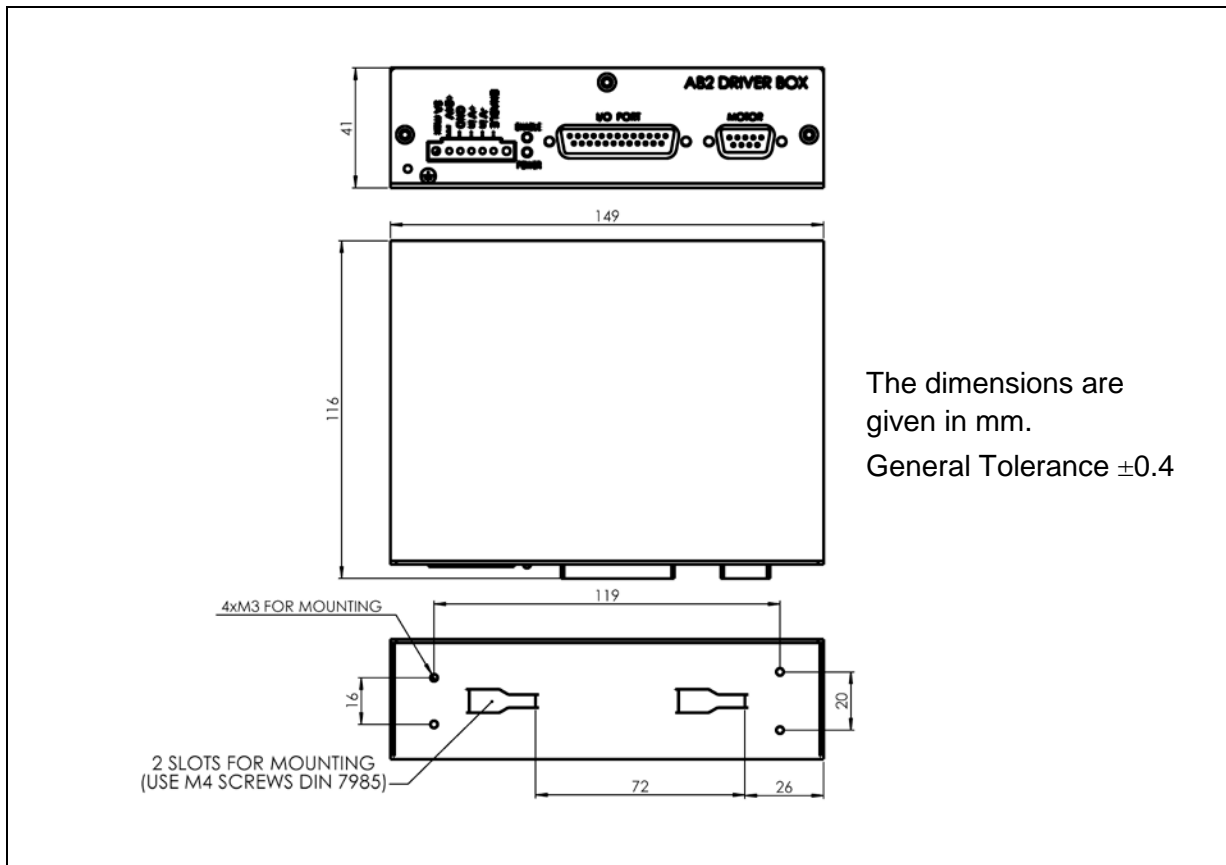

Figure 12: AB2 Layout

5.3 AB2 Pin Arrangement

Table 9: Control Terminal Pin Out

Pin	Signal Name	Function	Description
1	+24V	Input	+24 VDC Power Supply
2	GND	Ground	
3	+VIN	Input	Analog Command from controller.
4	-VIN	Input	Analog Command from controller.
5	ENABLE_IN	Input	Enable. See section 2.5

Table 10: Motor Output Port Pin Out

Pin	Signal Name	Function	Description
1	GND	Power supply ground	Safety input; shorted to pin 6 in order to verify the motor connection and to prevent driver operation without the motor.
2	N.C	Not used	
3	Motor_Up	High voltage output	Connected to the white motor terminal.
4	Motor_Common	High voltage output	Connected to the black motor terminal.
5	Motor_Down	High voltage output	Connected to the red motor terminal.
6	Motor Connected	Input	Safety input; shorted to pin 1 in order to verify the motor connection and prevent the driver operation without the motor.
7	GND	Power supply ground	Shorted to the shield
8	N.C	Not used	
9	N.C	Not used	

Table 11: I/O Port Pin Out

Pin	Name	Function	Description
1	+VIN	Input	Positive analog command input
2	GND		Ground
3	FAULT	Output	See section 2.6
4	GND		Ground
5	NC	Not used	
6	DIRECTION	Input	For Factory Use
7	NC	Not used	
8	GATE / INT_MODE	Input	Enables Gate Mode operation. (See section 4.1.3.1)
9	GND		Ground
10	LEFT_SW	Input	Left Limit Switch (see section 2.5)
11	-12V	Output	Accessory voltage for powering an external device. (Max 360mW). Return is the GND pin.
12	EMERGENCY_STOP	Input	Protection Input (see section 2.5)
13	USER_VOLTAGE	Input	External power supply for the opto-isolated type inputs. (see section 2.5.1)
14	-VIN	Input	Negative analog command input
15	GND		Ground
16	STEP_IN / GATE	Input	Used in Step & Gate modes. (see sections 4.1.2.1 , 4.1.3.1 and 2.5)
17	MRN	Input	Master Reset. Activated shorted to ground.
18	NC	Not used	
19	NC	Not used	
20	NC	Not used	
21	DC MODE	Input	Enables DC mode operation. (See Sections 4.1.4.1 and 2.5)
22	RIGHT_SW	Input	Right Limit Switch (see section 2.5)
23	+12V	Output	Accessory voltage for powering an external device. (Max 360mW). Return is the GND pin.
24	ENABLE_IN	Input	Enable signal (see section 2.5)
25	+5V	Output	Accessory voltage for powering an external device (max 3.5W). Return is the GND pin.