

Heason Lead-screw Actuator

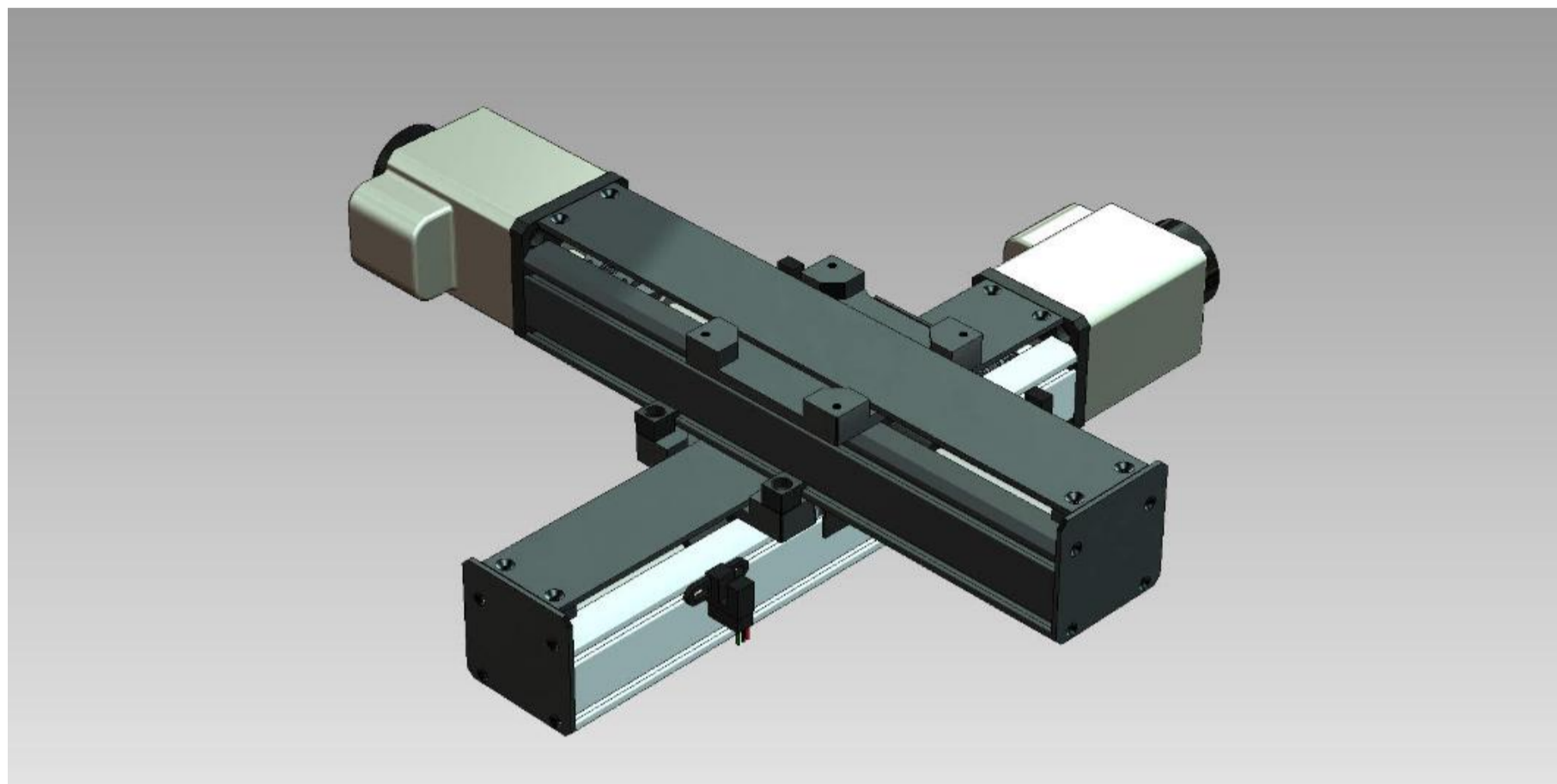

Description

- Extremely Cost Effective Linear Actuator targeted to the OEM markets
- Travel range from 25mm up to 300mm.
- Commercial or Precision grade options for increased Bi-directional repeatability.
- Multiple drive options: Integrated Stepper/Driver, Stepper Motor or Manual Knob.
- Unique carriage design provides a flexible mounting system for XY, XYZ, Gantry and telescopically extend travel
- Optional limit switches

Specifications

	Commercial (C)	Precision (P)
Axial load capacity	110 N	25 N
Maximum load capacity (static)	200 N	
Stroke	25, 50, 100, 150, 200, 250, 300 mm	
Screw Lead	6.35 mm	
Maximum linear speed	170 mm/s	
Resolution with micro-stepping	2 μ m	
Resolution per full step, 200 steps	32 μ m	
Bi-directional repeatability	\pm 0.2 μ m	\pm 0.1 μ m
Straightness, Flatness	100 μ m	
Motor (recommended)	DSMS Combo Stepper / Driver	
Bearings	Radial ball bearings	
Limit switches	Hall effect	
Duty Cycle	25 %*	
Efficiency	76 %*	
MTBF	20,000 hours*	
Weight	0.85 Kg max	0.9 Kg max

* please contact us for dynamic motion profile

For more information, please feel free to contact us at sales@heason.com or +44 (0)1403 755 855

www.heason.com

Dimensions

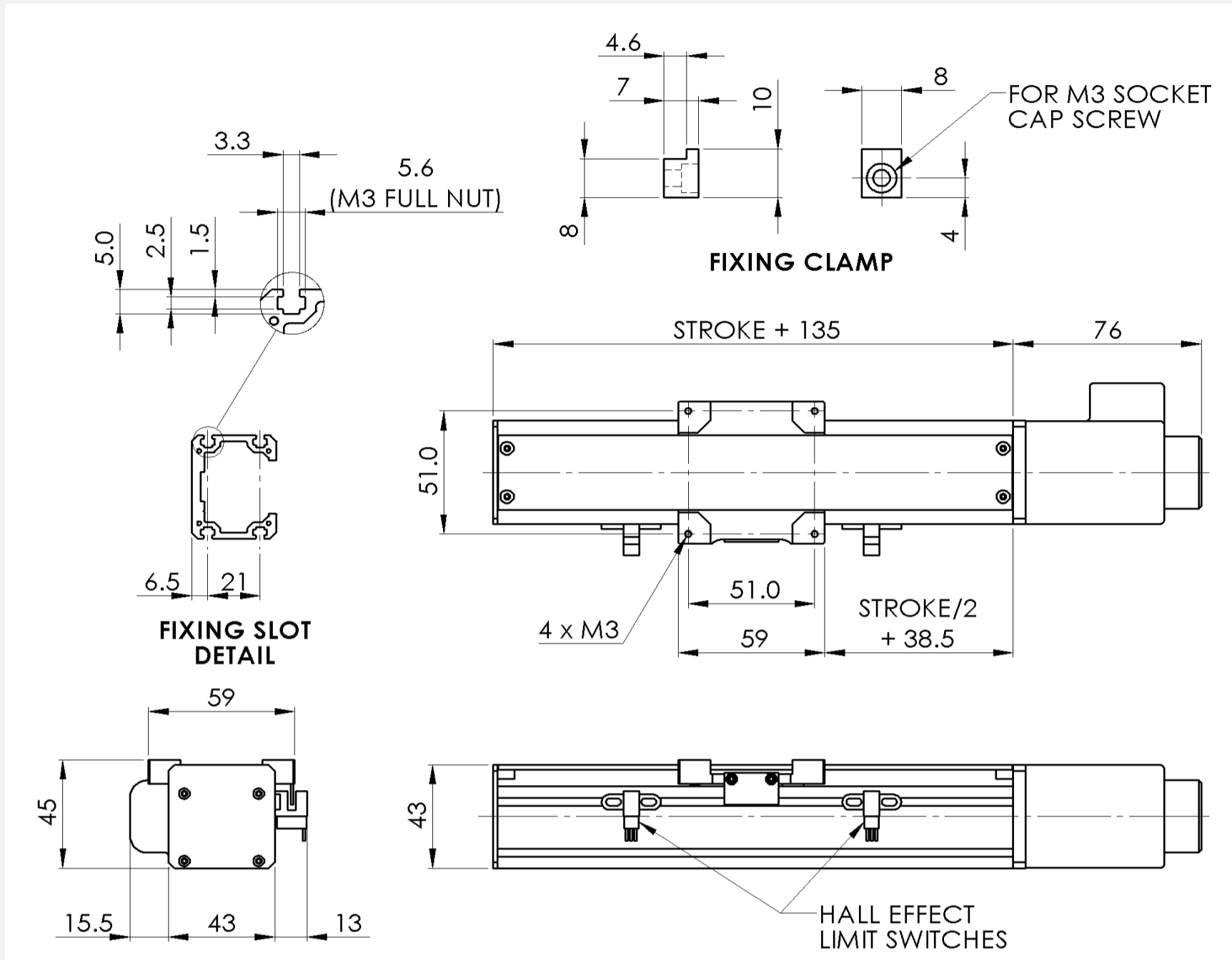

Part Numbering

HLA - 300 - C - LS - STDR - 00

HLA - Lead-screw version

25 - 25mm stroke
 50 - 50 mm stroke
 100 - 100mm stroke
 150 - 150mm stroke
 200 - 200mm stroke
 250 - 250mm stroke
 300 - 300mm stroke

P - Precision grade
 C - Commercial grade

LS - Limit switches
 00 - No Limit switches

Nema17 preparation
 STEP - Stepper Motor
 STDR - Stepper Motor/Driver Combo
 KNOB - Manual Knob

00 - standard
 SP - Special

For more information, please feel free to contact us at sales@heason.com or +44 (0)1403 755 855

www.heason.com