



T60 - Precision Linear Actuator

 THOMSON™
Linear Motion. Optimized.

T60

Ball Screw Drive, Slide Guide

Standard Features and Benefits

- Compact, robust and reliable
- High accuracy ball screw drive
- Stroke up to 1500 mm
- Load up to 10000 N
- Speed up to 3 m/s
- Hard chromed steel extension tube
- IP65 as standard
- Mounting accessories according to hydraulic cylinder standards available.

General Specifications

Parameter	T60
Profile size (w × h) [mm]	75 × 60
Type of screw	ball screw with single nut
Protection class	IP65
Lubrication	One point lubrication of ballscrew
Included accessories	–

Rod Idle Torque (M_{idle}) [Nm]

Input speed [rpm]	Screw lead (p) [mm]			
	p = 5	p = 10	p = 25	p = 50
500	1,5	1,5	2	3,5

M_{idle} = the input torque needed to move the rod with no load on it.

Performance Specifications

Parameter		T60
Stroke length (S max), maximum	[mm]	1500
Linear speed, maximum	[m/s]	3,0
Acceleration, maximum	[m/s ²]	8
Repeatability	[± mm]	0,05
Input speed, maximum	[rpm]	3000
Operation temperature limits	[°C]	-20 – 70
Dynamic load (F _x), maximum	[N]	10000
Dynamic load (F _y), maximum	[N]	100
Dynamic load (F _z), maximum	[N]	100
Dynamic load torque (M _z , M _y), max.	[Nm]	30
Drive shaft force (F _{rd}), maximum	[N]	500
Drive shaft torque (M _{ta}), maximum	[Nm]	48
Screw versions, diameter (d ₀) / lead (p)	[mm]	25/05, 25/10, 25/25, 25/50
Weight of units	[kg]	
of unit with zero stroke		4,60
of every 100 mm of stroke		0,95
of the rod with zero stroke		0,40
of every 100 mm of rod		0,35

¹ Value for the complete unit

T60

Ball Screw Drive, Slide Guide

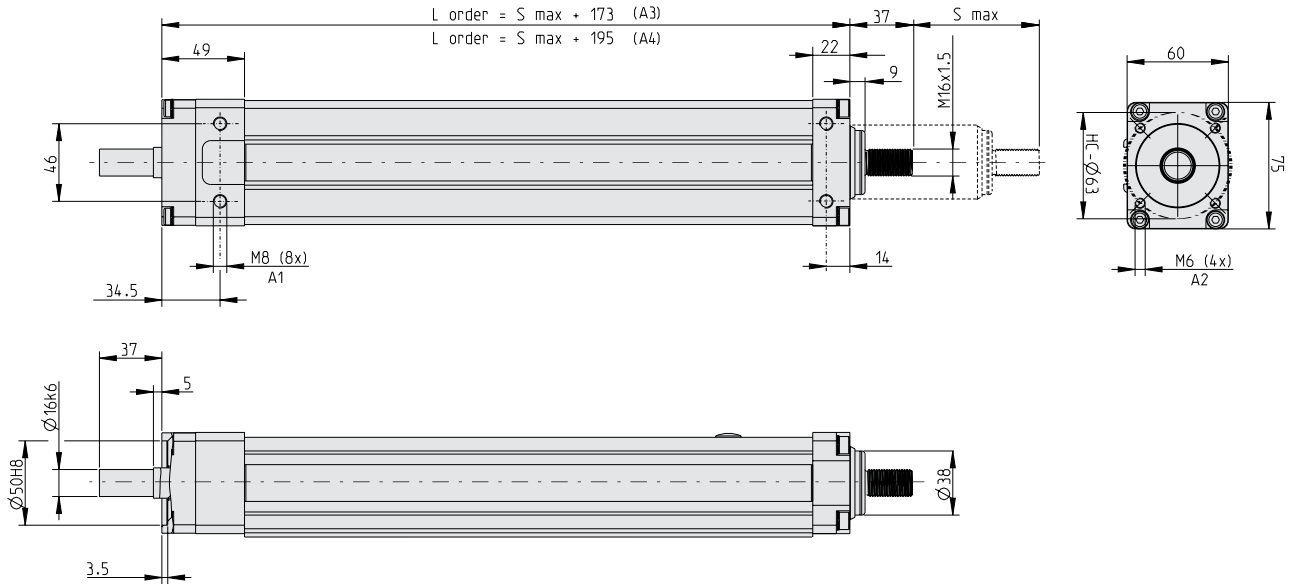

A1: depth ??
 A2: depth ??
 A3: screw 25/05 and 25/25
 A4: screw 25/10 and 25/50

T60 Ordering Key					
1	2	3	4	5	6
T06-B	2520	M	N	045	
1. Model T06-B = T60 unit			4. Type of adapter N = M16 × 1,5 outside thread		
2. Ball screw diameter, lead and tolerance class 2505 = 25 mm, 05 mm, T7 2510 = 25 mm, 10 mm, T7 2525 = 25 mm, 25 mm, T7 2550 = 25 mm, 50 mm, T7			5. Ordering length (L order) ••• = distance in cm		
3. Engineering unit M = metric			6. Protection option¹ +S1 = wash down protection		
¹ Leave blank if no protection option required.					

EUROPE

United Kingdom

Thomson
Fishleigh Road
Barnstaple
EX31 3UD
United Kingdom
Phone: +44 (0)1271 334 500
Fax: +44 (0)1271 334 501
E-mail: sales.uk@thomsonlinear.com

Germany

Thomson
Nürtinger Straße 70
72649 Wolfschlügen
Phone: +49 (0) 7022 504 100
Fax: +49 (0) 7022 504 405
E-Mail: sales.wolfschlügen@thomsonlinear.com

Sweden

Thomson
Box 9053
SE-291 09 Kristianstad
Sweden
Phone: +46 (0) 44-24 67 00
Fax: +46 (0) 44-24 40 85
E-mail: helpdesk.kid@thomsonlinear.com

Italy

Thomson
Largo Brughetti
I-20030 Bovisio Masciago
Italy
Phone: +39 0362 594260
Fax: +39 0362 594263
E-mail: info@thomsonlinear.it

France

Thomson
C.P 80018
12, Rue Antoine Becquerel – Z.I. Sud
F-72026 Le Mans Cedex 2
France
Phone: +33 (0) 243 50 03 30
Fax: +33 (0) 243 50 03 39
E-mail: sales.france@thomsonlinear.com

Spain

Thomson
Rbla Badal, 29-31 7th, 1st
08014 Barcelona
Spain
Phone: +34 (0) 9329 80278
Fax: +34 (0) 9329 80278
E-mail: josep.estaran@thomsonlinear.com

USA, CANADA and MEXICO

Thomson
203A West Rock Road
Radford, VA 24141 USA
Phone: 1-540-633-3549
Fax: 1-540-633-0294
E-mail: thomson@thomsonlinear.com
Literature: literature.thomsonlinear.com

ASIA

China

Thomson
Rm 2205, Scitech Tower
22 Jianguomen Wai Street
Beijing, China, 100004
Phone: +86 10 6515 0260
Fax: +86 10 6515 0263
E-mail: sales.china@thomsonlinear.com

Japan

Thomson
2F, Sigma Hatchobori Bldg,
2-7-1 Hatchobori Chuo-ku,
Tokyo 104-0032 Japan
Phone: +81-3-6222-1051
Fax: +81-3-6222-1055
E-mail: info@danahermotion.co.jp

Asia Pacific

Thomson
Unit A, 16 Floor, 169 Electric Road
Manulife Tower, North Point
Hong Kong
Phone: +852 2503 6581
Fax: +852 2571 8585
E-mail: victor.lim@thomsonlinear.com

Korea

Thomson
Room No. 715, Western Tower II
867, Janghang-dong,
Llsandong-gu, Koyang-city
Kyunggi-do, 410-380, Korea
Phone: +82 31 931 5170
Fax: +82 31 931 5176
E-mail: koreainfo@thomsonlinear.com

India

Thomson
Unit No 2, SDF 1
Seepz
Andheri, Mumbai 400 096, India
Phone: +91 22 28294058
Fax: +91 22 28394036
E-mail: girish.mahajani@danahermotion.com