

DuraTRUE™

True Planetary™ Gearheads

Ready for Immediate Delivery	
Precision	8 arc-minutes
Frame Sizes	60mm, 90mm, 115mm and 142mm
Torque Capacity	up to 834 Nm
Ratio Availability	3:1 thru 100:1
Radial load capacity	up to 11150 N
Mounting System	RediMount™

DuraTRUE™

- 1 **Sealed deep groove ball bearings**
provide high radial load carrying capability
- 2 **HRC 55-60 steel gears**
provide superior wear resistance
and increased backlash integrity
- 3 **Sealed deep groove ball bearing**
provides precision alignment of sun gear
- 4 **RediMount™ system**
provides error-free motor installation
- 5 **Anodized aluminum housing**
reduces weight and prevents corrosion

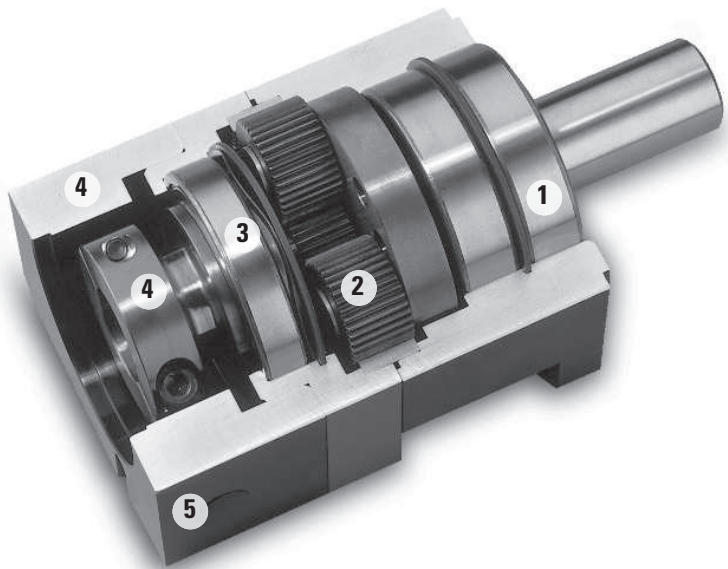

Micron True Planetary™ Gearheads
shipped within 24 hours!



*Need it fast? Go to the back cover
of the catalog for details.*

DuraTRUE™ Size 60

True Planetary™ Gearheads

Metric

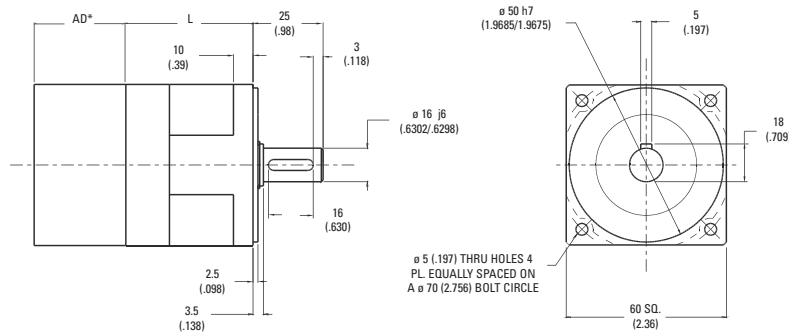

Ratio ¹	Dimension 'L' mm [in]	Backlash [arc-min]	Weight kg [lb]	Efficiency
3:1 to 10:1	53 [2.07]	8 max	1,0 [2.2]	93%
15:1 to 100:1	70 [2.76]	9 max	1,2 [2.7]	88%

All dimensions are: mm (inch)
 AD** = Adapter length
 Adapter length will vary depending on motor.
 Efficiency is calculated at 100% of the rated torque.

Performance Specifications

Part Number	Ratio ¹	10000 Hour Life				T _{peak} Nm [in-lb]	20000 Hour Life				J kg-cm ² [in-lb-sec ² ×10 ⁻⁴]	Torsional Stiffness Nm/arc-min [in-lb/arc-min]
		T _r (1000 rpm) Nm [in-lb]	T _r (2000 rpm) Nm [in-lb]	T _r (3000 rpm) Nm [in-lb]	T _r (4000 rpm) Nm [in-lb]		T _r (1000 rpm) Nm [in-lb]	T _r (2000 rpm) Nm [in-lb]	T _r (3000 rpm) Nm [in-lb]	T _r (4000 rpm) Nm [in-lb]		
DT60-003	3:1	15 [134]	12 [109]	11 [97]	10 [89]	52 [460]	12 [109]	10 [89]	9 [79]	8 [72]	0,52 [4.6]	0,9 [8.1]
DT60-004	4:1	19 [168]	16 [142]	14 [124]	13 [115]	44 [385]	16 [142]	13 [115]	12 [106]	11 [97]	0,46 [4.1]	0,9 [7.9]
DT60-005	5:1	17 [148]	14 [120]	12 [106]	11 [98]	46 [410]	14 [120]	11 [98]	10 [86]	9 [79]	0,46 [4.1]	0,9 [7.9]
DT60-007	7:1	16 [142]	13 [115]	11 [97]	10 [89]	41 [363]	13 [115]	10 [89]	9 [80]	8 [71]	0,46 [4.1]	0,9 [7.9]
DT60-010	10:1	15 [134]	14 [121]	13 [114]	12 [108]	45 [400]	14 [124]	13 [112]	11 [100]	10 [92]	0,44 [3.9]	0,8 [6.8]
DT60-015	15:1	25 [218]	20 [177]	18 [157]	16 [144]	52 [460]	20 [177]	16 [144]	14 [127]	13 [117]	0,46 [4.1]	0,9 [8.2]
DT60-020	20:1	26 [230]	24 [212]	21 [186]	20 [177]	46 [407]	24 [212]	20 [177]	18 [159]	17 [150]	0,46 [4.1]	0,9 [7.9]
DT60-025	25:1	24 [214]	22 [195]	19 [172]	18 [158]	52 [456]	22 [195]	18 [158]	16 [140]	15 [128]	0,46 [4.1]	0,9 [8.3]
DT60-030	30:1	28 [246]	25 [218]	22 [193]	20 [177]	52 [460]	25 [218]	20 [177]	18 [157]	16 [144]	0,44 [3.9]	1,0 [8.7]
DT60-040	40:1	27 [239]	26 [230]	26 [230]	24 [212]	46 [407]	27 [239]	24 [212]	21 [186]	20 [177]	0,44 [3.9]	0,9 [8.3]
DT60-050	50:1	25 [222]	24 [214]	24 [209]	22 [195]	52 [460]	25 [217]	22 [195]	19 [172]	18 [158]	0,44 [3.9]	0,9 [8.2]
DT60-070	70:1	24 [212]	23 [204]	23 [204]	21 [186]	46 [407]	24 [212]	21 [186]	18 [159]	17 [150]	0,44 [3.9]	0,9 [8.3]
DT60-100	100:1	20 [180]	19 [165]	18 [157]	17 [151]	51 [447]	19 [167]	17 [153]	16 [145]	16 [140]	0,44 [3.9]	0,9 [7.8]

Available with 24 hour delivery through the Gearhead Express Program.

¹ Ratios are exact, higher ratios and other custom options are also available, consult factory.
 T_r = Rated output torque at rated speed for specific hours of life.

T_{peak} = Allowable momentary peak torque for emergency stop or heavy shock loading.
 J = Mass moment of inertia reflected to the input shaft (including pinion assembly).

DuraTRUE™ Size 90

True Planetary™ Gearheads

Metric

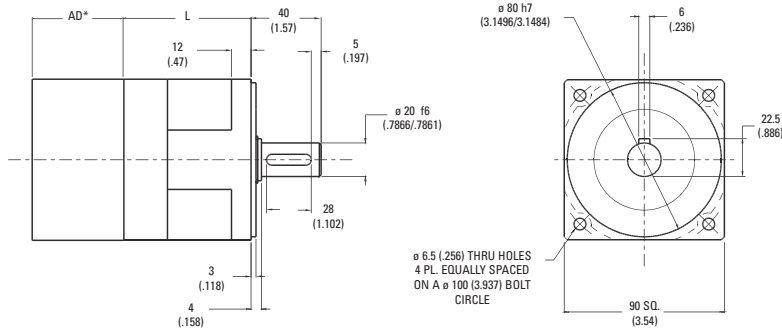

Ratio ¹	Dimension 'L' mm [in]	Backlash [arc-min]	Weight kg [lb]	Efficiency
3:1 to 10:1	67 [2.63]	8 max	3,0 [6.6]	93%
15:1 to 100:1	90 [3.53]	9 max	3,7 [8.1]	88%

All dimensions are: mm (inch)
 AD** = Adapter length
 Adapter length will vary depending on motor.
 Efficiency is calculated at 100% of the rated torque.

Performance Specifications

Part Number	Ratio ¹	10000 Hour Life				T _{peak} Nm [in-lb]	20000 Hour Life				J kg-cm ² [in-lb-sec ² x10 ⁻⁴]	Torsional Stiffness Nm/arc-min [in-lb/arc-min]
		T _r (1000 rpm) Nm [in-lb]	T _r (2000 rpm) Nm [in-lb]	T _r (3000 rpm) Nm [in-lb]	T _r (4000 rpm) Nm [in-lb]		T _r (1000 rpm) Nm [in-lb]	T _r (2000 rpm) Nm [in-lb]	T _r (3000 rpm) Nm [in-lb]	T _r (4000 rpm) Nm [in-lb]		
DT90-003	3:1	69 [614]	56 [499]	50 [442]	46 [405]	167 [1479]	56 [499]	46 [405]	41 [359]	37 [329]	2,22 [1.97]	4,9 [43.3]
DT90-004	4:1	80 [708]	67 [593]	60 [531]	55 [487]	157 [1389]	67 [593]	55 [487]	50 [443]	46 [407]	1,84 [1.60]	4,8 [42.4]
DT90-005	5:1	75 [664]	62 [549]	55 [486]	50 [446]	157 [1385]	62 [549]	50 [446]	45 [395]	41 [362]	1,76 [1.56]	4,8 [42.9]
DT90-007	7:1	73 [646]	60 [531]	53 [469]	48 [425]	157 [1389]	60 [531]	48 [425]	43 [381]	38 [336]	1,72 [1.50]	4,8 [42.4]
DT90-010	10:1	55 [488]	50 [439]	46 [411]	44 [392]	157 [1390]	51 [452]	46 [407]	43 [381]	41 [363]	1,63 [1.44]	4,0 [35.6]
DT90-015	15:1	93 [826]	84 [747]	79 [702]	74 [657]	167 [1479]	86 [764]	74 [657]	66 [582]	60 [534]	1,78 [1.58]	4,9 [43.7]
DT90-020	20:1	89 [788]	86 [761]	84 [743]	82 [726]	167 [1478]	88 [779]	84 [743]	77 [681]	71 [628]	1,77 [1.60]	4,8 [42.4]
DT90-025	25:1	84 [747]	81 [714]	78 [693]	77 [677]	167 [1479]	83 [730]	79 [698]	72 [640]	66 [587]	1,77 [1.56]	5,0 [44.5]
DT90-030	30:1	103 [908]	93 [826]	88 [780]	84 [747]	167 [1479]	95 [840]	86 [764]	81 [716]	74 [657]	1,64 [1.45]	4,9 [43.4]
DT90-040	40:1	93 [823]	89 [788]	87 [770]	86 [761]	167 [1478]	91 [805]	88 [779]	86 [761]	84 [743]	1,64 [1.40]	5,0 [44.2]
DT90-050	50:1	88 [776]	84 [747]	82 [728]	81 [714]	167 [1479]	86 [759]	83 [730]	81 [712]	79 [698]	1,63 [1.45]	5,0 [44.2]
DT90-070	70:1	86 [761]	82 [726]	80 [708]	79 [699]	167 [1478]	84 [743]	81 [717]	79 [699]	78 [690]	1,63 [1.40]	5,0 [44.2]
DT90-100	100:1	75 [663]	69 [608]	65 [576]	63 [555]	167 [1479]	69 [613]	64 [562]	60 [533]	58 [513]	1,63 [1.45]	4,4 [38.5]

Available with 24 hour delivery through the Gearhead Express Program.

¹ Ratios are exact, higher ratios and other custom options are also available, consult factory.
 T_r = Rated output torque at rated speed for specific hours of life.

T_{peak} = Allowable momentary peak torque for emergency stop or heavy shock loading.
 J = Mass moment of inertia reflected to the input shaft (including pinion assembly).

DuraTRUE™ Size 115

True Planetary™ Gearheads

Metric

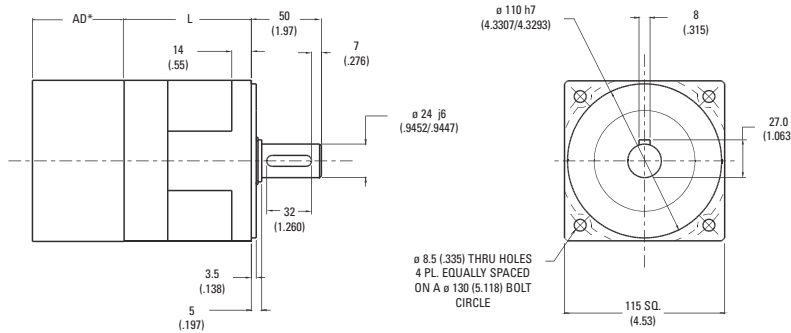

Ratio ¹	Dimension 'L' mm [in]	Backlash [arc-min]	Weight kg [lb]	Efficiency
3:1 to 10:1	88 [3.46]	8 max	5,7 [12.7]	93%
15:1 to 100:1	119 [4.69]	9 max	7,3 [16.2]	88%

All dimensions are: mm (inch)
 AD** = Adapter length
 Adapter length will vary depending on motor.
 Efficiency is calculated at 100% of the rated torque.

Performance Specifications

Part Number	Ratio ¹	10000 Hour Life				T _{peak} Nm [in-lb]	20000 Hour Life				J kg-cm ² [in-lb-sec ² ×10 ⁻⁴]	Torsional Stiffness Nm/arc-min [in-lb/arc-min]
		T _r (1000 rpm) Nm [in-lb]	T _r (2000 rpm) Nm [in-lb]	T _r (3000 rpm) Nm [in-lb]	T _r (4000 rpm) Nm [in-lb]		T _r (1000 rpm) Nm [in-lb]	T _r (2000 rpm) Nm [in-lb]	T _r (3000 rpm) Nm [in-lb]	T _r (4000 rpm) Nm [in-lb]		
DT115-003	3:1	105 [932]	86 [757]	76 [670]	70 [615]	284 [2511]	86 [757]	70 [615]	62 [544]	56 [499]	4,39 [3.88]	13,9 [123.4]
DT115-004	4:1	123 [1089]	98 [867]	91 [805]	85 [752]	284 [2513]	102 [903]	85 [752]	75 [664]	70 [620]	3,1 [2.7]	13,9 [122.7]
DT115-005	5:1	116 [1025]	91 [803]	83 [738]	77 [677]	284 [2511]	94 [833]	77 [677]	68 [599]	62 [550]	2,88 [2.55]	11,6 [102.4]
DT115-007	7:1	113 [1000]	88 [779]	81 [717]	75 [664]	284 [2513]	92 [814]	75 [664]	65 [575]	60 [531]	2,81 [2.5]	13,9 [122.7]
DT115-010	10:1	90 [796]	81 [715]	76 [668]	72 [635]	284 [2511]	83 [737]	75 [661]	70 [618]	66 [588]	2,47 [2.18]	11,6 [102.4]
DT115-015	15:1	171 [1510]	139 [1226]	123 [1086]	113 [996]	284 [2511]	139 [1226]	113 [996]	100 [882]	91 [809]	2,95 [2.61]	12,9 [114.1]
DT115-020	20:1	175 [1549]	161 [1425]	143 [1266]	132 [1168]	284 [2513]	161 [1425]	132 [1168]	118 [1044]	109 [965]	2,95 [2.6]	13,9 [122.7]
DT115-025	25:1	167 [1474]	153 [1350]	135 [1195]	124 [1096]	284 [2511]	153 [1350]	124 [1096]	110 [971]	101 [891]	2,90 [2.57]	14,1 [125.0]
DT115-030	30:1	203 [1794]	171 [218]	151 [1337]	139 [1226]	284 [2513]	171 [1510]	139 [1226]	123 [1086]	113 [996]	2,48 [2.20]	14,1 [124.4]
DT115-040	40:1	181 [1602]	175 [1549]	190 [1682]	161 [1425]	284 [2513]	178 [1575]	161 [1425]	143 [1266]	132 [1168]	2,47 [2.2]	14,1 [124.4]
DT115-050	50:1	173 [1535]	167 [1474]	162 [1435]	153 [1350]	284 [2511]	170 [1510]	153 [1350]	135 [1195]	124 [1096]	2,47 [2.19]	14,1 [125.0]
DT115-070	70:1	171 [1513]	165 [1460]	180 [1593]	151 [1336]	284 [2513]	168 [1487]	151 [1336]	133 [1177]	122 [1080]	2,47 [2.2]	14,1 [124.4]
DT115-100	100:1	123 [1087]	112 [995]	107 [943]	103 [907]	284 [2511]	114 [1006]	104 [921]	99 [873]	95 [840]	2,47 [2.19]	11,4 [100.6]

Available with 24 hour delivery through the Gearhead Express Program.

¹ Ratios are exact, higher ratios and other custom options are also available, consult factory.
 T_r = Rated output torque at rated speed for specific hours of life.

T_{peak} = Allowable momentary peak torque for emergency stop or heavy shock loading.
 J = Mass moment of inertia reflected to the input shaft (including pinion assembly).

DuraTRUE™ Size 142

True Planetary™ Gearheads

Metric

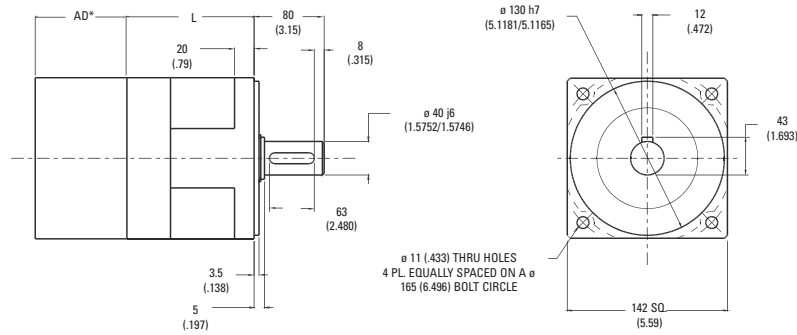

Ratio ¹	Dimension 'L' mm [in]	Backlash [arc-min]	Weight kg [lb]	Efficiency
3:1 to 10:1	121 [4.77]	8 max	12,8 [28.3]	93%
15:1 to 100:1	170 [6.71]	9 max	17,2 [38.0]	88%

All dimensions are: mm (inch)
 AD** = Adapter length
 Adapter length will vary depending on motor.
 Efficiency is calculated at 100% of the rated torque.

Performance Specifications

Part Number	Ratio ¹	10000 Hour Life				T _{peak} Nm [in-lb]	20000 Hour Life				J kg-cm ² [in-lb-sec ² ×10 ⁻⁴]	Torsional Stiffness Nm/arc-min [in-lb/arc-min]
		T _r (1000 rpm) Nm [in-lb]	T _r (2000 rpm) Nm [in-lb]	T _r (3000 rpm) Nm [in-lb]	T _r (4000 rpm) Nm [in-lb]		T _r (1000 rpm) Nm [in-lb]	T _r (2000 rpm) Nm [in-lb]	T _r (3000 rpm) Nm [in-lb]	T _r (4000 rpm) Nm [in-lb]		
DT142-003	3:1	372 [3289]	302 [2671]	267 [2365]	245 [2170]	834 [7377]	302 [2671]	245 [2170]	217 [1921]	199 [1762]	23,2 [2.05]	51,8 [458.7]
DT142-004	4:1	430 [3806]	353 [3124]	315 [2788]	290 [2567]	834 [7381]	353 [3124]	290 [2567]	259 [2292]	239 [2115]	15,1 [1.3]	52,9 [467.1]
DT142-005	5:1	410 [3625]	333 [2944]	295 [2607]	270 [2391]	834 [7377]	333 [2944]	270 [2391]	239 [2118]	219 [1942]	14,7 [1.30]	52,6 [465.1]
DT142-007	7:1	405 [3584]	328 [2903]	290 [2597]	265 [2345]	834 [7381]	328 [2903]	265 [2345]	234 [2071]	214 [1894]	14,5 [1.3]	50,5 [445.9]
DT142-010	10:1	229 [2022]	204 [1808]	190 [1685]	181 [1598]	834 [7377]	211 [1871]	189 [1673]	176 [1559]	167 [1479]	12,1 [1.07]	41,3 [365.1]
DT142-015	15:1	524 [4634]	471 [4167]	433 [3833]	397 [3516]	834 [7377]	484 [4287]	397 [3516]	352 [3114]	323 [2856]	15,1 [1.34]	59,6 [527.6]
DT142-020	20:1	500 [4425]	476 [4213]	461 [4080]	450 [3983]	834 [7381]	489 [4328]	458 [4053]	408 [3611]	376 [3328]	14,8 [1.3]	58,5 [516.6]
DT142-025	25:1	480 [4248]	456 [4038]	441 [3903]	430 [3801]	834 [7377]	469 [4154]	438 [3876]	388 [3432]	356 [3148]	14,8 [1.31]	57,7 [510.6]
DT142-030	30:1	578 [5113]	524 [4634]	493 [4359]	471 [4167]	834 [7377]	535 [4731]	484 [4287]	433 [3833]	397 [3516]	12,2 [1.08]	59,9 [529.9]
DT142-040	40:1	521 [4611]	500 [4425]	486 [4301]	476 [4213]	834 [7381]	510 [4514]	489 [4328]	476 [4213]	458 [4053]	12,9 [1.1]	57,5 [507.7]
DT142-050	50:1	501 [4435]	480 [4248]	466 [4128]	456 [4038]	834 [7377]	490 [4336]	469 [4154]	456 [4037]	438 [3876]	12,1 [1.07]	57,8 [511.1]
DT142-070	70:1	496 [4390]	475 [4204]	461 [4080]	451 [3991]	834 [7381]	485 [4292]	464 [4106]	451 [3991]	433 [3882]	12,1 [1.1]	54,4 [480.4]
DT142-100	100:1	314 [2782]	287 [2543]	272 [2408]	262 [2314]	834 [7377]	291 [2574]	266 [2353]	252 [2228]	242 [2141]	12,1 [1.07]	42,9 [379.5]

Available with 24 hour delivery through the Gearhead Express Program.

¹ Ratios are exact, higher ratios and other custom options are also available, consult factory.
 T_r = Rated output torque at rated speed for specific hours of life.

T_{peak} = Allowable momentary peak torque for emergency stop or heavy shock loading.
 J = Mass moment of inertia reflected to the input shaft (including pinion assembly).

Radial and Axial Load Ratings

DT60

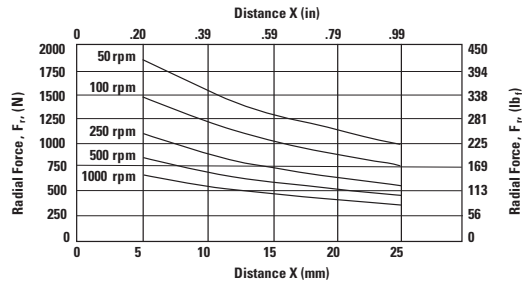
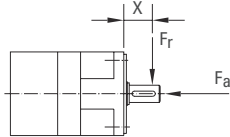

Speed rpm	Axial Load, F_a N [lb _f]
50	3075 [692]
100	2441 [549]
250	1798 [405]
500	1427 [321]
1000	1133 [255]

DT90

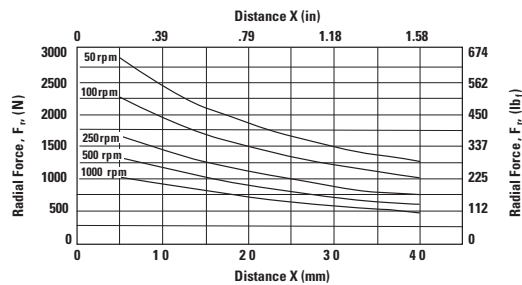
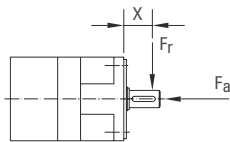

Speed rpm	Axial Load, F_a N [lb _f]
50	4506 [1014]
100	3576 [805]
250	2635 [593]
500	2091 [471]
1000	1660 [373]

DT115

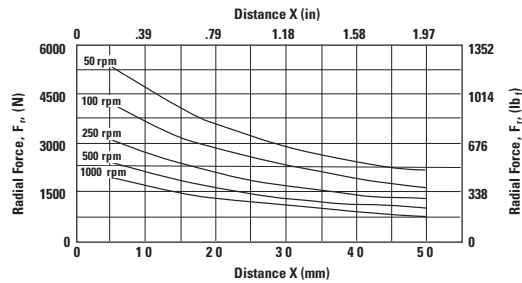
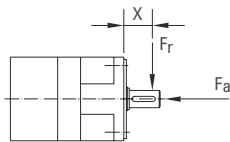

Speed rpm	Axial Load, F_a N [lb _f]
50	8196 [1844]
100	6505 [1464]
250	4793 [1078]
500	3804 [856]
1000	3019 [679]

DT142

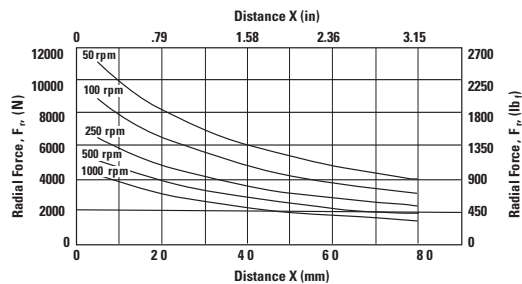
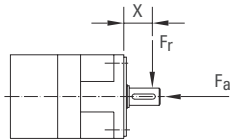

Speed rpm	Axial Load, F_a N [lb _f]
50	17023 [3830]
100	13511 [3040]
250	9956 [2240]
500	7902 [1778]
1000	6271 [1411]

These graphs display the allowable radial load at a given distance (X) from the mounting surface based on an L_{10} life of 10,000 hours for the mean output speed n_{mout} , as described on page 10,

DuraTRUE 90™

Right Angle Gearheads

Ready for Immediate Delivery	
Precision	8 arc-minutes
Frame Sizes	60mm, 90mm, 115mm and 142mm
Torque Capacity	up to 842 Nm
Ratio Availability	1:1 thru 500:1
Radial load capacity	up to 11150 N
Mounting System	RediMount™

- 1 Deep Groove Ball bearings**
provide high radial load carrying capabilities
- 2 HRC 55-60 steel gears**
provide superior wear resistance and increased backlash integrity
- 3 Innovative PowerTRUE™ gearing**
delivers smooth, quiet geared reduction
- 4 RediMount™ system**
provides error-free installation

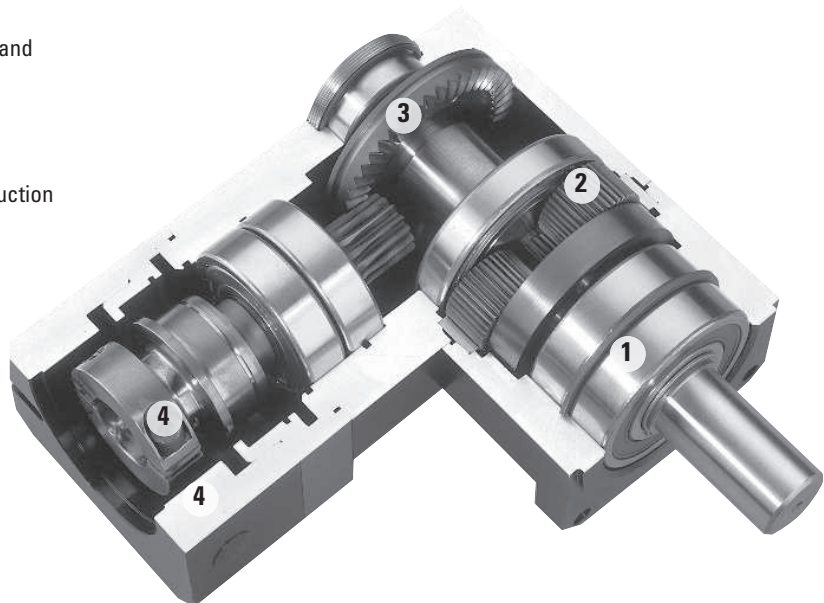

DuraTRUE 90™ Size 60

Right Angle Gearheads

Metric

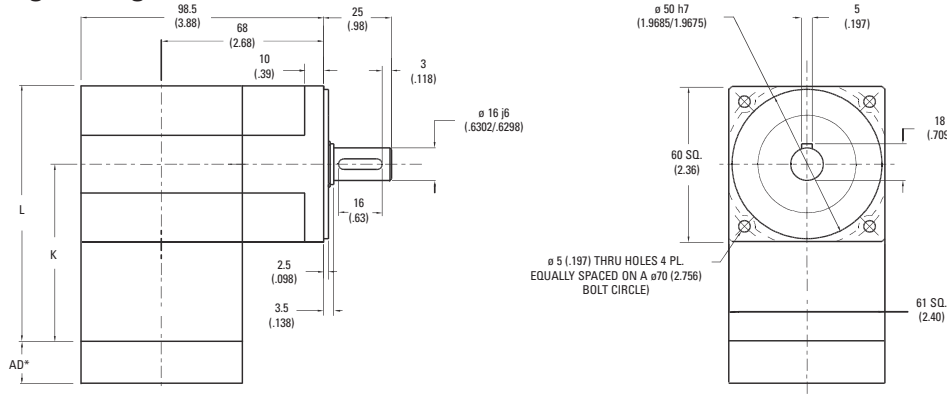

Ratio ¹	Dimension 'K' mm [in]	Dimension 'L' mm [in]	Backlash [arc-min]	Weight kg [lb]	Efficiency
5:1 to 50:1	79 [3.11]	109,5 [4.31]	9 max	2,5 [5.5]	93%
60:1 to 500:1	96 [3.79]	127 [4.99]	9 max	2,7 [6]	88%

All dimensions are: mm (inch)
 AD** = Adapter length
 Adapter length will vary depending on motor.
 Efficiency is calculated at 100% of the rated torque.

Performance Specifications

Part Number	Ratio ¹	10000 Hour Life			T _{peak} Nm [in-lb]	20000 Hour Life			J kg-cm ² [in-lb-sec ² x10 ⁻⁴]	Torsional Stiffness Nm/arc-min [in-lb/arc-min]
		T _r (1000 rpm) Nm [in-lb]	T _r (3000 rpm) Nm [in-lb]	T _r (5000 rpm) Nm [in-lb]		T _r (1000 rpm) Nm [in-lb]	T _r (3000 rpm) Nm [in-lb]	T _r (5000 rpm) Nm [in-lb]		
DTR60-005	5:1	18 [157]	13 [113]	11 [97]	52 [460]	14 [127]	10 [92]	9 [79]	0,42 [3.7]	2,3 [20.1]
DTR60-006	6:1	19 [166]	13 [119]	12 [102]	52 [460]	15 [134]	11 [97]	9 [83]	0,42 [3.7]	2,3 [20.3]
DTR60-009	9:1	21 [187]	15 [134]	13 [115]	52 [460]	17 [152]	12 [109]	11 [94]	0,36 [3.1]	2,3 [20.2]
DTR60-010	10:1	21 [182]	15 [131]	13 [112]	49 [435]	17 [148]	12 [106]	10 [91]	0,41 [3.5]	2,3 [20.2]
DTR60-012	12:1	18 [161]	17 [147]	14 [126]	45 [402]	18 [161]	13 [119]	12 [102]	0,33 [3.0]	2,3 [20.4]
DTR60-015	15:1	23 [206]	17 [148]	14 [127]	50 [445]	19 [167]	14 [120]	12 [103]	0,32 [2.9]	2,3 [20.4]
DTR60-020	20:1	24 [211]	18 [161]	16 [138]	51 [450]	21 [182]	15 [131]	13 [112]	0,33 [2.8]	2,3 [20.3]
DTR60-025	25:1	24 [214]	19 [172]	17 [148]	51 [455]	22 [195]	16 [140]	14 [120]	0,32 [2.7]	2,3 [20.3]
DTR60-030	30:1	18 [155]	15 [134]	14 [124]	49 [430]	16 [143]	14 [124]	13 [115]	0,35 [2.8]	1,7 [14.8]
DTR60-040	40:1	18 [161]	16 [139]	15 [130]	49 [430]	17 [149]	15 [129]	14 [120]	0,33 [2.7]	1,7 [14.8]
DTR60-050	50:1	19 [165]	16 [143]	15 [134]	49 [430]	17 [153]	15 [133]	14 [124]	0,32 [2.6]	1,7 [14.8]
DTR60-060	60:1	28 [244]	18 [155]	15 [133]	52 [460]	20 [175]	14 [126]	12 [108]	0,42 [3.7]	2,3 [20.2]
DTR60-075	75:1	28 [248]	20 [178]	17 [153]	50 [445]	23 [201]	16 [144]	14 [124]	0,35 [3.0]	2,3 [20.2]
DTR60-090	90:1	28 [244]	20 [175]	17 [150]	52 [460]	22 [198]	16 [142]	14 [122]	0,36 [3.1]	2,3 [20.0]
DTR60-100	100:1	27 [237]	19 [171]	16 [146]	49 [435]	22 [193]	16 [138]	13 [119]	0,41 [3.5]	2,2 [19.9]
DTR60-120	120:1	24 [210]	22 [192]	19 [164]	45 [402]	24 [210]	18 [155]	15 [133]	0,33 [3.0]	2,3 [20.2]
DTR60-125	125:1	29 [257]	23 [207]	20 [178]	51 [455]	27 [235]	19 [168]	16 [144]	0,32 [2.8]	2,4 [21.5]
DTR60-150	150:1	30 [268]	22 [193]	19 [165]	50 [445]	22 [198]	18 [156]	15 [134]	0,35 [2.9]	2,3 [20.1]
DTR60-200	200:1	31 [275]	24 [210]	20 [180]	51 [450]	27 [237]	19 [171]	16 [146]	0,41 [3.4]	2,3 [20.2]
DTR60-250	250:1	32 [279]	25 [224]	22 [193]	51 [455]	29 [254]	21 [182]	18 [156]	0,32 [2.7]	2,4 [21.5]
DTR60-300	300:1	23 [202]	20 [175]	18 [162]	49 [430]	21 [186]	18 [162]	17 [150]	0,35 [2.8]	1,7 [14.8]
DTR60-400	400:1	24 [210]	20 [181]	19 [169]	49 [430]	22 [194]	19 [168]	18 [156]	0,33 [2.7]	1,7 [14.8]
DTR60-500	500:1	24 [215]	21 [186]	20 [175]	49 [430]	23 [199]	20 [173]	18 [162]	0,30 [2.7]	1,7 [14.8]

¹ Ratios are exact, higher ratios and other custom options are also available, consult factory.
 T_r = Rated output torque at rated speed for specific hours of life.

T_{peak} = Allowable momentary peak torque for emergency stop or heavy shock loading.
 J = Mass moment of inertia reflected to the input shaft (including pinion assembly).

DuraTRUE 90™ Size 60S (Slim Line)

Right Angle Gearheads

Metric

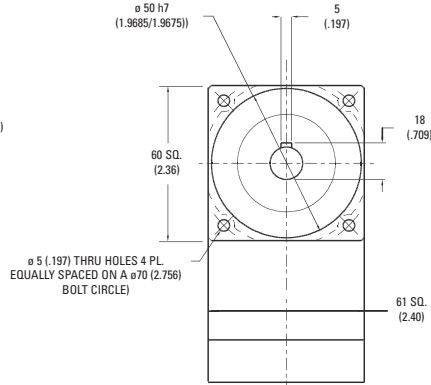
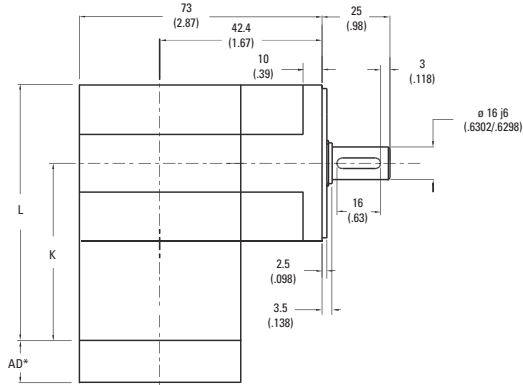

Ratio ¹	Dimension 'K' mm [in]	Dimension 'L' mm [in]	Backlash [arc-min]	Weight kg [lb]	Efficiency
1:1 to 5:1P	79 [3.11]	109,5 [4.31]	8 max	2,3 [5]	98%
5:1T to 50:1	96 [3.79]	127 [4.99]	9 max	2,5 [5.5]	93%
60:1 to 500:1	114 [4.48]	144 [5.68]	9 max	2,7 [6]	88%

All dimensions are: mm (inch)
 AD** = Adapter length
 Adapter length will vary depending on motor.
 Efficiency is calculated at 100% of the rated torque.

Performance Specifications

Part Number	Ratio ¹	10000 Hour Life			T _{peak} Nm [in-lb]	20000 Hour Life			J kg-cm ² [in-lb-sec ² x10 ⁻⁴]	Torsional Stiffness Nm/arc-min [in-lb/arc-min]
		T _r (1000 rpm) Nm [in-lb]	T _r (3000 rpm) Nm [in-lb]	T _r (5000 rpm) Nm [in-lb]		T _r (1000 rpm) Nm [in-lb]	T _r (3000 rpm) Nm [in-lb]	T _r (5000 rpm) Nm [in-lb]		
DTR60S-001	1:1	7 [66]	7 [60]	6 [54]	25 [217]	7 [61]	6 [56]	6 [50]	0,79 [7.0]	1,8 [15.8]
DTR60S-002	2:1	16 [145]	15 [132]	14 [120]	45 [400]	15 [134]	14 [122]	12 [111]	0,41 [3.6]	2,7 [23.8]
DTR60S-003	3:1	10 [92]	10 [84]	9 [76]	34 [300]	10 [85]	9 [78]	8 [70]	0,35 [3.1]	3,0 [26.9]
DTR60S-004	4:1	8 [68]	7 [62]	6 [56]	30 [264]	7 [63]	6 [57]	6 [52]	0,32 [2.9]	3,2 [28.2]
DTR60S-005P	5:1P	6 [56]	6 [51]	5 [46]	23 [200]	6 [52]	5 [47]	5 [43]	0,32 [2.8]	3,3 [28.8]
DTR60S-005T	5:1T	23 [200]	18 [162]	16 [138]	46 [407]	21 [182]	15 [132]	13 [112]	0,42 [3.7]	3,3 [28.8]
DTR60S-006	6:1	19 [171]	16 [145]	16 [141]	46 [407]	19 [167]	15 [134]	15 [130]	0,41 [3.7]	2,1 [18.8]
DTR60S-009	9:1	12 [109]	10 [92]	10 [90]	36 [321]	12 [106]	10 [85]	9 [83]	0,35 [3.1]	2,7 [23.7]
DTR60S-010	10:1	20 [176]	18 [160]	16 [145]	46 [407]	20 [174]	17 [154]	15 [134]	0,39 [3.5]	2,1 [18.5]
DTR60S-012	12:1	9 [80]	8 [68]	7 [66]	32 [280]	9 [78]	7 [63]	7 [61]	0,33 [3.0]	3,0 [26.1]
DTR60S-015	15:1	13 [112]	12 [102]	10 [92]	37 [330]	12 [110]	11 [98]	10 [85]	0,33 [2.9]	3,1 [27.4]
DTR60S-020	20:1	9 [82]	8 [75]	8 [68]	46 [407]	9 [81]	8 [72]	7 [63]	0,31 [2.8]	2,9 [26.0]
DTR60S-025	25:1	8 [68]	7 [62]	6 [56]	25 [220]	8 [67]	7 [59]	6 [52]	0,31 [2.7]	3,1 [27.3]
DTR60S-030	30:1	13 [114]	12 [109]	12 [105]	38 [339]	13 [114]	12 [107]	11 [101]	0,32 [2.8]	2,5 [22.4]
DTR60S-040	40:1	10 [84]	9 [81]	9 [77]	33 [292]	9 [84]	9 [79]	8 [74]	0,30 [2.7]	2,8 [25.2]
DTR60S-050	50:1	8 [69]	7 [66]	7 [63]	25 [225]	8 [69]	7 [65]	7 [61]	0,30 [2.6]	3,0 [26.8]
DTR60S-060	60:1	21 [182]	20 [180]	20 [177]	46 [407]	21 [182]	20 [178]	20 [175]	0,42 [3.7]	2,0 [18.1]
DTR60S-075	75:1	13 [116]	13 [114]	13 [112]	39 [345]	13 [115]	13 [113]	12 [110]	0,33 [3.0]	2,6 [23.4]
DTR60S-090	90:1	13 [116]	13 [114]	13 [113]	39 [348]	13 [116]	13 [114]	13 [111]	0,35 [3.1]	2,6 [23.3]
DTR60S-100	100:1	21 [183]	20 [181]	20 [180]	46 [407]	21 [182]	20 [180]	20 [178]	0,40 [3.5]	2,1 [18.3]
DTR60S-120	120:1	10 [85]	10 [84]	9 [83]	34 [300]	10 [85]	9 [84]	9 [82]	0,33 [3.0]	2,9 [25.8]
DTR60S-125	125:1	8 [70]	8 [69]	8 [68]	26 [230]	8 [70]	8 [68]	8 [67]	0,31 [2.8]	3,1 [27.3]
DTR60S-150	150:1	13 [116]	13 [115]	13 [114]	40 [351]	13 [116]	13 [115]	13 [114]	0,33 [2.9]	2,6 [23.4]
DTR60S-200	200:1	21 [183]	21 [182]	21 [181]	46 [407]	21 [183]	21 [182]	20 [181]	0,39 [3.4]	1,9 [17.0]
DTR60S-250	250:1	8 [70]	8 [70]	8 [69]	26 [230]	8 [70]	8 [69]	8 [69]	0,31 [2.7]	3,1 [27.3]
DTR60S-300	300:1	13 [116]	13 [116]	13 [115]	40 [354]	13 [116]	13 [116]	13 [115]	0,32 [2.8]	2,5 [22.4]
DTR60S-400	400:1	10 [86]	10 [85]	10 [85]	34 [304]	10 [86]	10 [85]	10 [85]	0,31 [2.7]	2,8 [25.2]
DTR60S-500	500:1	8 [70]	8 [70]	8 [70]	26 [230]	8 [70]	8 [70]	8 [70]	0,30 [2.7]	3,0 [26.8]

Ratio 5P is designed using only PowerTRUE face gearing technology.
 Ratio 5T adds a True Planetary gearing stage for increased torque capacity.
¹ Ratios are exact, higher ratios and other custom options are also available, consult factory.

T_r = Rated output torque at rated speed for specific hours of life.
 J = Mass moment of inertia reflected to the input shaft (including pinion assembly)
 T_{peak} = Allowable momentary peak torque for emergency stop or heavy shock loading.

DuraTRUE 90™ Size 90

Right Angle Gearheads

Metric

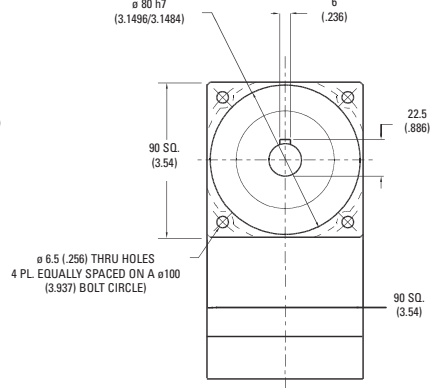
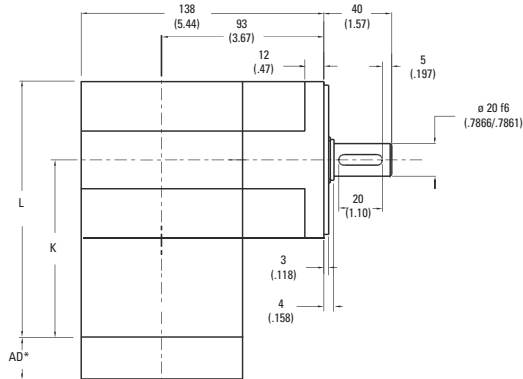

Ratio ¹	Dimension 'K' mm [in]	Dimension 'L' mm [in]	Backlash [arc-min]	Weight kg [lb]	Efficiency
5:1 to 50:1	101 [3.99]	146 [5.76]	9 max	4,8 [10]	93%
60:1 to 500:1	124 [4.89]	169 [6.66]	9 max	5,5 [12]	88%

All dimensions are: mm (inch)
 AD** = Adapter length
 Adapter length will vary depending on motor.
 Efficiency is calculated at 100% of the rated torque.

Performance Specifications

Part Number	Ratio ¹	10000 Hour Life			T _{peak} Nm [in-lb]	20000 Hour Life			J [in-lb-sec ² ×10 ⁻⁴] kg-cm ²	Torsional Stiffness Nm/arc-min [in-lb/arc-min]
		T _r (1000 rpm) Nm [in-lb]	T _r (3000 rpm) Nm [in-lb]	T _r (5000 rpm) Nm [in-lb]		T _r (1000 rpm) Nm [in-lb]	T _r (3000 rpm) Nm [in-lb]	T _r (5000 rpm) Nm [in-lb]		
DTR90-005	5:1	79 [702]	58 [515]	50 [442]	167 [1479]	66 [582]	47 [418]	41 [359]	1,64 [14.5]	7,8 [69.2]
DTR90-006	6:1	82 [722]	61 [544]	53 [467]	167 [1479]	69 [614]	50 [442]	43 [379]	1,63 [14.4]	5,5 [48.2]
DTR90-009	9:1	75 [665]	69 [614]	60 [527]	167 [1479]	75 [665]	56 [499]	48 [428]	1,39 [12.3]	5,5 [48.8]
DTR90-010	10:1	79 [703]	68 [599]	58 [514]	167 [1479]	76 [676]	55 [486]	47 [417]	1,62 [14.3]	5,5 [48.4]
DTR90-012	12:1	57 [509]	57 [509]	57 [509]	144 [1272]	57 [509]	57 [509]	53 [467]	1,29 [11.4]	5,5 [49.0]
DTR90-015	15:1	82 [723]	75 [664]	66 [580]	167 [1479]	80 [707]	62 [549]	53 [471]	1,26 [11.1]	5,5 [49.0]
DTR90-020	20:1	83 [737]	77 [681]	72 [633]	167 [1479]	81 [720]	68 [599]	58 [514]	1,28 [11.3]	5,5 [48.7]
DTR90-025	25:1	71 [624]	71 [624]	71 [624]	167 [1479]	71 [624]	71 [624]	62 [549]	1,26 [11.1]	5,5 [48.7]
DTR90-030	30:1	64 [568]	55 [488]	51 [452]	167 [1479]	59 [526]	51 [452]	47 [418]	1,38 [12.2]	4,0 [35.6]
DTR90-040	40:1	67 [590]	58 [509]	53 [472]	167 [1479]	62 [546]	53 [471]	49 [437]	1,28 [11.3]	4,0 [35.6]
DTR90-050	50:1	69 [608]	59 [525]	55 [488]	167 [1479]	63 [562]	55 [486]	51 [452]	1,25 [11.1]	4,0 [35.6]
DTR90-060	60:1	106 [941]	80 [709]	69 [608]	167 [1479]	90 [800]	65 [576]	56 [494]	1,63 [14.4]	5,5 [48.6]
DTR90-075	75:1	98 [870]	90 [799]	79 [698]	167 [1479]	96 [851]	75 [661]	64 [567]	1,39 [12.3]	5,5 [48.4]
DTR90-090	90:1	98 [866]	90 [800]	78 [687]	167 [1479]	98 [866]	73 [650]	63 [558]	1,39 [12.3]	5,4 [48.0]
DTR90-100	100:1	103 [916]	88 [780]	76 [670]	167 [1479]	100 [881]	72 [633]	61 [543]	1,62 [14.3]	5,4 [47.8]
DTR90-120	120:1	75 [663]	75 [663]	75 [663]	144 [1272]	75 [663]	75 [663]	69 [608]	1,29 [11.4]	5,5 [48.5]
DTR90-125	125:1	85 [751]	85 [751]	85 [751]	167 [1479]	85 [751]	85 [751]	75 [661]	1,26 [11.1]	5,8 [51.6]
DTR90-150	150:1	106 [942]	98 [865]	85 [756]	167 [1479]	98 [866]	81 [715]	69 [614]	1,39 [12.3]	5,5 [48.3]
DTR90-200	200:1	109 [960]	100 [887]	93 [825]	167 [1479]	108 [938]	88 [780]	76 [670]	1,61 [14.2]	5,5 [48.5]
DTR90-250	250:1	92 [813]	92 [813]	92 [813]	167 [1479]	92 [813]	92 [813]	81 [715]	1,26 [11.1]	5,8 [51.5]
DTR90-300	300:1	84 [740]	72 [636]	67 [589]	167 [1479]	77 [685]	67 [589]	62 [545]	1,38 [12.2]	4,0 [35.5]
DTR90-400	400:1	87 [769]	75 [663]	69 [615]	167 [1479]	80 [711]	69 [614]	64 [569]	1,28 [11.3]	4,0 [35.5]
DTR90-500	500:1	90 [792]	77 [684]	72 [636]	167 [1479]	83 [732]	72 [633]	67 [589]	1,20 [10.6]	4,0 [35.6]

¹ Ratios are exact, higher ratios and other custom options are also available, consult factory.
 T_r = Rated output torque at rated speed for specific hours of life.

T_{peak} = Allowable momentary peak torque for emergency stop or heavy shock loading.
 J = Mass moment of inertia reflected to the input shaft (including pinion assembly).

DuraTRUE 90™ Size 90S (Slim Line)

Right Angle Gearheads

Metric

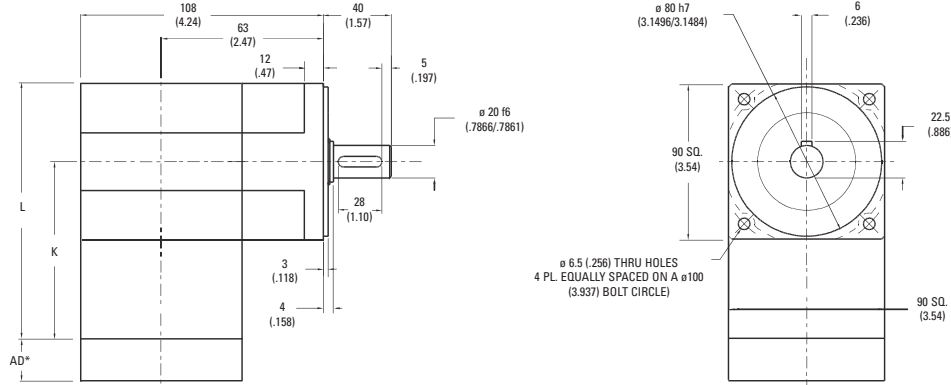

Ratio ¹	Dimension 'K' mm [in]	Dimension 'L' mm [in]	Backlash [arc-min]	Weight kg [lb]	Efficiency
1:1 to 5:1P	101 [3.99]	146 [5.76]	8 max	4,1 [9]	98%
5:1T to 50:1	124 [4.89]	169 [6.66]	9 max	4,8 [10]	93%
60:1 to 500:1	114 [5.79]	192 [7.56]	9 max	5,5 [12]	88%

All dimensions are: mm (inch)
 AD** = Adapter length
 Adapter length will vary depending on motor.
 Efficiency is calculated at 100% of the rated torque.

Performance Specifications

Part Number	Ratio ¹	10000 Hour Life			T _{peak} Nm [in-lb]	20000 Hour Life			J kg-cm ² [in-lb-sec ² x10 ⁻⁴]	Torsional Stiffness Nm/arc-min [in-lb/arc-min]
		T _r (1000 rpm) Nm [in-lb]	T _r (3000 rpm) Nm [in-lb]	T _r (5000 rpm) Nm [in-lb]		T _r (1000 rpm) Nm [in-lb]	T _r (3000 rpm) Nm [in-lb]	T _r (5000 rpm) Nm [in-lb]		
DTR90S-001	1:1	21 [188]	19 [171]	17 [155]	62 [548]	20 [173]	18 [158]	16 [143]	3,11 [27.5]	4,3 [37.9]
DTR90S-002	2:1	48 [426]	44 [389]	40 [352]	140 [1237]	44 [394]	41 [359]	37 [325]	1,59 [14.1]	6,5 [57.2]
DTR90S-003	3:1	32 [281]	29 [256]	26 [232]	114 [1005]	29 [260]	27 [237]	24 [214]	1,37 [12.1]	7,3 [64.6]
DTR90S-004	4:1	24 [215]	22 [196]	20 [177]	87 [772]	22 [199]	20 [181]	19 [164]	1,27 [11.2]	7,6 [67.7]
DTR90S-005P	5:1P	18 [158]	16 [144]	15 [131]	73 [645]	17 [146]	15 [133]	14 [121]	1,25 [11.0]	7,8 [69.2]
DTR90S-005T	5:1T	64 [568]	55 [483]	53 [469]	140 [1237]	63 [556]	50 [446]	49 [433]	1,64 [14.5]	5,1 [45.1]
DTR90S-006	6:1	57 [501]	48 [426]	47 [414]	140 [1237]	55 [490]	44 [394]	43 [382]	1,63 [14.4]	5,1 [45.1]
DTR90S-009	9:1	37 [331]	32 [281]	31 [273]	124 [1095]	37 [323]	29 [260]	28 [252]	1,37 [12.1]	6,4 [56.9]
DTR90S-010	10:1	58 [516]	53 [471]	48 [426]	140 [1237]	58 [510]	51 [452]	44 [394]	1,54 [13.7]	5,0 [44.5]
DTR90S-012	12:1	29 [253]	24 [215]	24 [209]	94 [836]	28 [247]	22 [199]	22 [193]	1,31 [11.6]	7,1 [62.7]
DTR90S-015	15:1	38 [340]	35 [311]	32 [281]	128 [1131]	38 [336]	34 [298]	29 [260]	1,28 [11.3]	7,4 [65.8]
DTR90S-020	20:1	29 [261]	27 [238]	24 [215]	140 [1237]	29 [257]	26 [228]	22 [199]	1,22 [10.8]	7,1 [62.4]
DTR90S-025	25:1	22 [192]	20 [175]	18 [158]	80 [705]	21 [189]	19 [168]	17 [146]	1,20 [10.6]	7,4 [65.6]
DTR90S-030	30:1	39 [348]	38 [333]	36 [318]	131 [1161]	39 [346]	37 [327]	35 [307]	1,25 [11.1]	6,1 [53.8]
DTR90S-040	40:1	30 [266]	29 [255]	28 [243]	99 [880]	30 [265]	28 [250]	27 [235]	1,19 [10.6]	6,8 [60.5]
DTR90S-050	50:1	22 [196]	21 [188]	20 [179]	82 [725]	22 [195]	21 [184]	20 [173]	1,17 [10.4]	7,3 [64.2]
DTR90S-060	60:1	60 [535]	60 [527]	59 [520]	140 [1237]	60 [534]	59 [524]	58 [514]	1,63 [14.4]	4,9 [43.5]
DTR90S-075	75:1	40 [352]	39 [346]	38 [340]	136 [1200]	40 [351]	39 [344]	38 [336]	1,31 [11.6]	6,4 [56.2]
DTR90S-090	90:1	40 [353]	39 [348]	39 [343]	136 [1206]	40 [352]	39 [346]	38 [339]	1,37 [12.1]	6,3 [55.8]
DTR90S-100	100:1	61 [536]	60 [532]	60 [527]	140 [1237]	61 [536]	60 [530]	59 [524]	1,55 [13.7]	5,0 [43.9]
DTR90S-120	120:1	31 [270]	30 [266]	30 [262]	103 [908]	30 [269]	30 [265]	29 [260]	1,31 [11.6]	7,0 [62.0]
DTR90S-125	125:1	22 [198]	22 [195]	22 [192]	84 [740]	22 [198]	22 [194]	21 [189]	1,23 [10.8]	7,4 [65.5]
DTR90S-150	150:1	40 [354]	40 [351]	39 [348]	138 [1218]	40 [353]	39 [350]	39 [346]	1,29 [11.4]	6,3 [56.1]
DTR90S-200	200:1	61 [538]	60 [535]	60 [533]	140 [1237]	61 [537]	60 [534]	60 [531]	1,52 [13.5]	4,6 [40.7]
DTR90S-250	250:1	23 [199]	22 [198]	22 [196]	85 [750]	22 [199]	22 [197]	22 [195]	1,21 [10.7]	7,4 [65.4]
DTR90S-300	300:1	40 [355]	40 [353]	40 [352]	139 [1230]	40 [354]	40 [352]	40 [350]	1,26 [11.1]	6,1 [53.7]
DTR90S-400	400:1	31 [271]	31 [270]	30 [269]	104 [924]	31 [271]	30 [270]	30 [268]	1,20 [10.6]	6,8 [60.5]
DTR90S-500	500:1	23 [200]	22 [199]	22 [198]	85 [755]	23 [200]	22 [198]	22 [197]	1,18 [10.4]	7,3 [64.2]

Ratio 5P is designed using only PowerTRUE face gearing technology.
 Ratio 5T adds a True Planetary gearing stage for increased torque capacity.
¹ Ratios are exact, higher ratios and other custom options are also available, consult factory.

T_r = Rated output torque at rated speed for specific hours of life.
 J = Mass moment of inertia reflected to the input shaft (including pinion assembly)
 T_{peak} = Allowable momentary peak torque for emergency stop or heavy shock loading.

DuraTRUE 90™ Size 115

Right Angle Gearheads

Metric

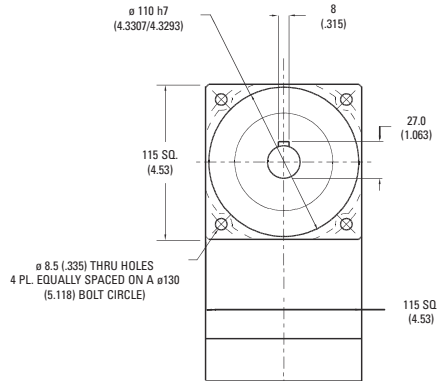
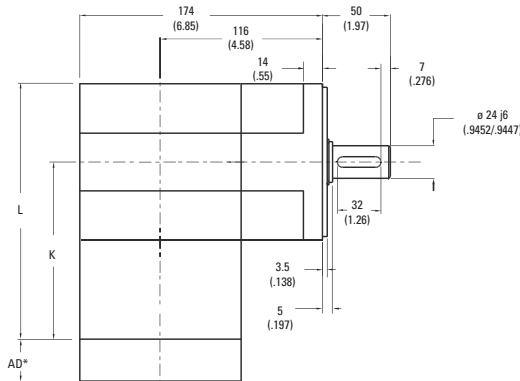

Ratio ¹	Dimension 'K' mm [in]	Dimension 'L' mm [in]	Backlash [arc-min]	Weight kg [lb]	Efficiency
5:1 to 50:1	137 [5.40]	195 [7.67]	8 max	11 [24]	93%
60:1 to 500:1	168,4 [6.63]	226 [8.90]	9 max	12 [27]	88%

All dimensions are: mm (inch)

AD** = Adapter length

Adapter length will vary depending on motor. Efficiency is calculated at 100% of the rated torque.

Performance Specifications

Part Number	Ratio ¹	10000 Hour Life			T _{peak} Nm [in-lb]	20000 Hour Life			J kg-cm ² [in-lb-sec ² ×10 ⁻⁴]	Torsional Stiffness Nm/arc-min [in-lb/arc-min]
		T _r (1000 rpm) Nm [in-lb]	T _r (3000 rpm) Nm [in-lb]	T _r (5000 rpm) Nm [in-lb]		T _r (1000 rpm) Nm [in-lb]	T _r (3000 rpm) Nm [in-lb]	T _r (5000 rpm) Nm [in-lb]		
DTR115-005	5:1	123 [1086]	88 [781]	76 [670]	284 [2511]	100 [882]	72 [634]	61 [544]	2,79 [24.7]	15,3 [135]
DTR115-006	6:1	130 [1147]	93 [825]	80 [708]	284 [2511]	105 [932]	76 [670]	65 [575]	2,77 [24.5]	12,5 [110]
DTR115-009	9:1	146 [1295]	105 [932]	90 [799]	284 [2511]	119 [1052]	86 [757]	73 [649]	2,37 [21.0]	12,6 [112]
DTR115-010	10:1	143 [1262]	103 [908]	88 [779]	284 [2511]	116 [1025]	83 [738]	72 [633]	2,75 [24.3]	13,1 [116]
DTR115-012	12:1	137 [1210]	115 [1016]	98 [871]	284 [2511]	130 [1147]	93 [825]	80 [708]	2,19 [19.4]	12,7 [112]
DTR115-015	15:1	161 [1425]	116 [1025]	99 [880]	284 [2511]	131 [1158]	94 [833]	81 [715]	2,14 [18.9]	12,7 [112]
DTR115-020	20:1	164 [1453]	126 [1118]	108 [959]	284 [2511]	143 [1262]	103 [908]	88 [779]	2,18 [19.3]	13,2 [117]
DTR115-025	25:1	167 [1474]	135 [1195]	116 [1025]	284 [2511]	153 [1350]	110 [971]	94 [833]	2,14 [18.9]	13,2 [117]
DTR115-030	30:1	105 [930]	90 [796]	83 [736]	284 [2511]	97 [861]	83 [737]	77 [681]	2,34 [20.7]	11,5 [102]
DTR115-040	40:1	109 [967]	94 [831]	87 [770]	284 [2511]	101 [894]	87 [769]	80 [712]	2,17 [19.2]	11,5 [102]
DTR115-050	50:1	112 [995]	97 [858]	90 [796]	284 [2511]	104 [921]	90 [794]	83 [737]	2,13 [18.8]	11,5 [102]
DTR115-060	60:1	169 [1495]	121 [1075]	104 [923]	284 [2511]	137 [1214]	99 [873]	85 [749]	2,77 [24.5]	13,2 [117]
DTR115-075	75:1	194 [1715]	139 [1233]	120 [1059]	284 [2511]	139 [1233]	113 [1002]	97 [860]	2,35 [20.8]	13,1 [116]
DTR115-090	90:1	191 [1687]	137 [1214]	118 [1041]	284 [2511]	155 [1371]	111 [986]	96 [846]	2,37 [21.0]	12,5 [110]
DTR115-100	100:1	186 [1644]	134 [1183]	115 [1015]	284 [2511]	151 [1336]	109 [962]	93 [825]	2,75 [24.3]	13,0 [115]
DTR115-120	120:1	178 [1577]	150 [1324]	128 [1135]	284 [2511]	169 [1495]	121 [1075]	104 [923]	2,19 [19.4]	12,6 [111]
DTR115-125	125:1	200 [1774]	162 [1438]	139 [1233]	284 [2511]	184 [1624]	132 [1168]	113 [1002]	2,14 [18.9]	13,2 [117]
DTR115-150	150:1	210 [1857]	151 [1336]	130 [1147]	284 [2511]	170 [1509]	123 [1085]	105 [932]	2,35 [20.8]	13,1 [116]
DTR115-200	200:1	214 [1893]	165 [1457]	141 [1250]	284 [2511]	186 [1644]	134 [1183]	115 [1015]	2,73 [24.2]	13,2 [116]
DTR115-250	250:1	217 [1921]	176 [1557]	151 [1336]	284 [2511]	199 [1759]	143 [1265]	123 [1085]	2,14 [18.9]	13,2 [117]
DTR115-300	300:1	137 [1212]	117 [1037]	108 [959]	284 [2511]	127 [1122]	109 [960]	100 [887]	2,34 [20.7]	11,5 [102]
DTR115-400	400:1	142 [1260]	122 [1083]	113 [1003]	284 [2511]	132 [1165]	113 [1002]	105 [928]	2,17 [19.2]	11,5 [102]
DTR115-500	500:1	146 [1296]	126 [1118]	117 [1037]	284 [2511]	136 [1200]	117 [1035]	109 [960]	2,03 [18.0]	11,5 [102]

¹ Ratios are exact, higher ratios and other custom options are also available, consult factory.
T_r = Rated output torque at rated speed for specific hours of life.

T_{peak} = Allowable momentary peak torque for emergency stop or heavy shock loading.
J = Mass moment of inertia reflected to the input shaft (including pinion assembly).

DuraTRUE 90™ Size 115S (Slim Line)

Right Angle Gearheads

Metric

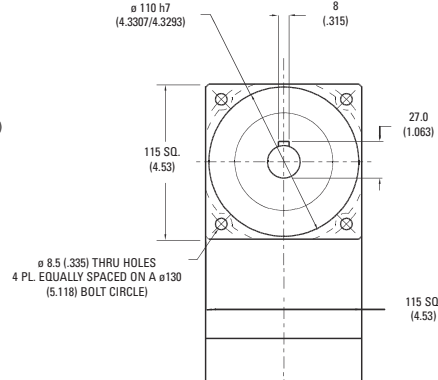
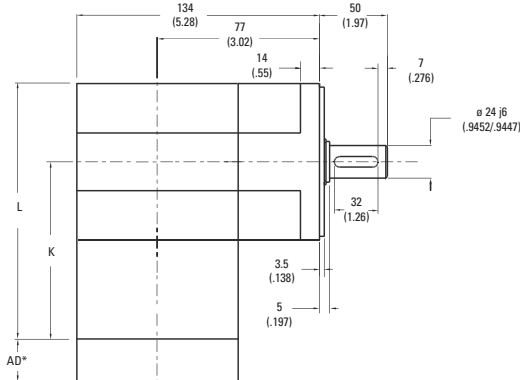

Ratio ¹	Dimension 'K' mm [in]	Dimension 'L' mm [in]	Backlash [arc-min]	Weight kg [lb]	Efficiency
1:1 to 5:1P	137 [5.40]	195 [7.67]	8 max	9 [20]	98%
5:1T to 50:1	168,4 [6.63]	226 [8.90]	9 max	11 [24]	93%
60:1 to 500:1	200 [7.87]	257 [10.13]	9 max	12 [27]	88%

All dimensions are: mm (inch)

AD** = Adapter length

Adapter length will vary depending on motor. Efficiency is calculated at 100% of the rated torque.

Performance Specifications

Part Number	Ratio ¹	10000 Hour Life			T _{peak} Nm [in-lb]	20000 Hour Life			J kg-cm ² [in-lb-sec ² x10 ⁻⁴]	Torsional Stiffness Nm/arc-min [in-lb/arc-min]
		T _r (1000 rpm) Nm [in-lb]	T _r (3000 rpm) Nm [in-lb]	T _r (5000 rpm) Nm [in-lb]		T _r (1000 rpm) Nm [in-lb]	T _r (3000 rpm) Nm [in-lb]	T _r (5000 rpm) Nm [in-lb]		
DTR115S-001	1:1	63 [554]	57 [506]	52 [457]	203 [1800]	58 [512]	53 [467]	48 [422]	5,28 [46.7]	7,6 [67.6]
DTR115S-002	2:1	112 [989]	102 [903]	92 [816]	283 [2505]	103 [913]	94 [834]	85 [754]	2,71 [23.9]	12,5 [111]
DTR115S-003	3:1	87 [768]	79 [701]	72 [634]	256 [2265]	80 [709]	73 [647]	66 [585]	2,33 [20.6]	14,2 [126]
DTR115S-004	4:1	58 [511]	53 [467]	48 [422]	199 [1760]	53 [472]	49 [431]	44 [390]	2,16 [19.1]	14,9 [132]
DTR115S-005P	5:1P	43 [384]	40 [350]	36 [316]	164 [1450]	40 [354]	37 [323]	33 [292]	2,12 [18.8]	15,3 [135]
DTR115S-005T	5:1T	170 [1505]	126 [1117]	108 [958]	283 [2505]	143 [1262]	102 [907]	88 [778]	2,78 [24.6]	15,3 [135]
DTR115S-006	6:1	131 [1163]	112 [989]	109 [960]	283 [2505]	129 [1138]	103 [913]	100 [887]	2,77 [24.5]	10,2 [90.7]
DTR115S-009	9:1	102 [903]	87 [768]	84 [746]	281 [2490]	100 [884]	80 [709]	78 [689]	2,32 [20.5]	12,8 [113]
DTR115S-010	10:1	135 [1198]	124 [1094]	112 [989]	283 [2505]	134 [1183]	118 [1048]	103 [913]	2,63 [23.2]	10,2 [90.3]
DTR115S-012	12:1	68 [601]	58 [511]	56 [496]	217 [1920]	66 [588]	53 [472]	52 [458]	2,22 [19.6]	14,0 [124]
DTR115S-015	15:1	105 [930]	96 [849]	87 [768]	283 [2505]	104 [919]	92 [814]	80 [709]	2,18 [19.3]	14,6 [130]
DTR115S-020	20:1	70 [619]	64 [565]	58 [511]	283 [2505]	69 [612]	61 [542]	53 [472]	2,08 [18.4]	14,0 [124]
DTR115S-025	25:1	52 [465]	48 [424]	43 [384]	183 [1620]	52 [459]	46 [406]	40 [354]	2,04 [18.0]	14,6 [129]
DTR115S-030	30:1	107 [951]	103 [910]	98 [869]	283 [2505]	107 [945]	101 [892]	95 [840]	2,13 [18.9]	12,5 [111]
DTR115S-040	40:1	72 [633]	68 [606]	65 [579]	231 [2040]	71 [629]	67 [594]	63 [559]	2,03 [18.0]	13,8 [122]
DTR115S-050	50:1	54 [475]	51 [454]	49 [434]	188 [1665]	53 [472]	50 [446]	47 [419]	1,99 [17.6]	14,5 [128]
DTR115S-060	60:1	140 [1242]	138 [1224]	136 [1207]	283 [2505]	140 [1239]	137 [1217]	135 [1194]	2,78 [24.6]	10,0 [88.5]
DTR115S-075	75:1	109 [963]	107 [947]	105 [930]	283 [2505]	109 [960]	106 [939]	104 [919]	2,22 [19.7]	12,7 [112]
DTR115S-090	90:1	109 [964]	107 [951]	106 [937]	283 [2505]	109 [962]	107 [945]	105 [927]	2,33 [20.6]	12,6 [112]
DTR115S-100	100:1	141 [1245]	140 [1235]	138 [1224]	283 [2505]	141 [1244]	139 [1230]	137 [1217]	2,64 [23.3]	10,1 [89.5]
DTR115S-120	120:1	73 [642]	72 [633]	70 [624]	238 [2108]	72 [641]	71 [629]	70 [617]	2,23 [19.7]	13,9 [123]
DTR115S-125	125:1	54 [481]	53 [473]	52 [465]	193 [1710]	54 [480]	53 [469]	52 [459]	2,08 [18.4]	14,6 [129]
DTR115S-150	150:1	109 [967]	108 [959]	107 [951]	283 [2505]	109 [966]	108 [955]	107 [945]	2,19 [19.4]	12,7 [112]
DTR115S-200	200:1	141 [1248]	140 [1243]	140 [1237]	283 [2505]	141 [1247]	140 [1240]	139 [1234]	2,59 [22.9]	9,8 [87.1]
DTR115S-250	250:1	55 [483]	54 [479]	54 [475]	196 [1735]	54 [482]	54 [477]	53 [472]	2,05 [18.1]	14,6 [129]
DTR115S-300	300:1	109 [969]	109 [965]	109 [961]	283 [2505]	109 [968]	109 [963]	108 [958]	2,14 [18.9]	12,5 [111]
DTR115S-400	400:1	73 [645]	73 [642]	72 [640]	244 [2160]	73 [645]	72 [641]	72 [638]	2,04 [18.1]	13,8 [122]
DTR115S-500	500:1	55 [484]	54 [482]	54 [480]	198 [1755]	55 [483]	54 [481]	54 [478]	2,00 [17.7]	14,5 [128]

Ratio 5P is designed using only PowerTRUE face gearing technology.

Ratio 5T adds a True Planetary gearing stage for increased torque capacity.

¹ Ratios are exact, higher ratios and other custom options are also available, consult factory.

T_r = Rated output torque at rated speed for specific hours of life.

J = Mass moment of inertia reflected to the input shaft (including pinion assembly)

T_{peak} = Allowable momentary peak torque for emergency stop or heavy shock loading.

DuraTRUE 90™ Size 142

Right Angle Gearheads

Metric

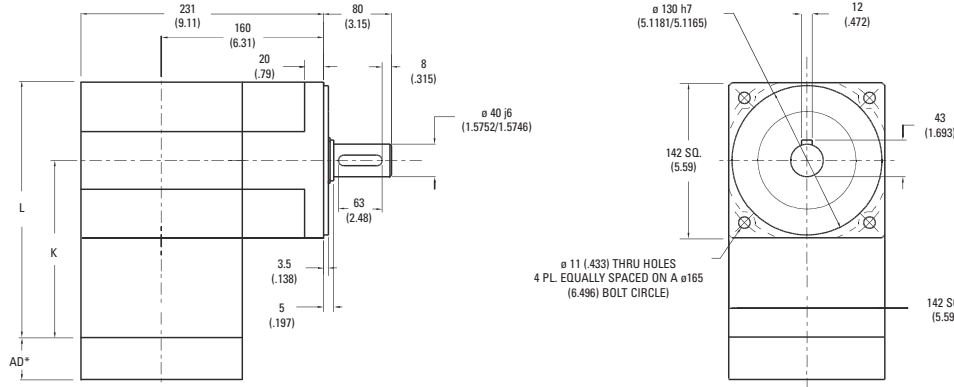

Ratio ¹	Dimension 'K' mm [in]	Dimension 'L' mm [in]	Backlash [arc-min]	Weight kg [lb]	Efficiency
5:1 to 50:1	160 [6.29]	231 [9.09]	9 max	24 [53]	93%
60:1 to 500:1	209 [8.23]	280 [11.03]	9 max	28 [62]	88%

All dimensions are: mm (inch)
 AD** = Adapter length
 Adapter length will vary depending on motor. Efficiency is calculated at 100% of the rated torque.

Performance Specifications

Part Number	Ratio ¹	10000 Hour Life			T _{peak} Nm [in-lb]	20000 Hour Life			J kg-cm ² [in-lb-sec ² x10 ⁻⁴]	Torsional Stiffness Nm/arc-min [in-lb/arc-min]
		T _r (1000 rpm) Nm [in-lb]	T _r (3000 rpm) Nm [in-lb]	T _r (5000 rpm) Nm [in-lb]		T _r (1000 rpm) Nm [in-lb]	T _r (3000 rpm) Nm [in-lb]	T _r (5000 rpm) Nm [in-lb]		
DTR142-005	5:1	433 [3833]	311 [2757]	267 [2365]	833 [7377]	352 [3114]	253 [2239]	217 [1921]	13,9 [123]	47,4 [419]
DTR142-006	6:1	454 [4020]	329 [2912]	282 [2498]	833 [7377]	372 [3289]	267 [2365]	229 [2029]	13,8 [122]	38,6 [342]
DTR142-009	9:1	444 [3934]	372 [3289]	319 [2821]	833 [7377]	420 [3714]	302 [2671]	259 [2292]	11,8 [104]	39,1 [346]
DTR142-010	10:1	448 [3965]	363 [3210]	311 [2754]	833 [7377]	410 [3625]	295 [2607]	253 [2237]	13,7 [121]	40,6 [360]
DTR142-012	12:1	319 [2825]	319 [2825]	319 [2825]	798 [7062]	319 [2825]	319 [2825]	282 [2498]	10,9 [96.3]	39,3 [348]
DTR142-015	15:1	463 [4096]	410 [3625]	351 [3110]	833 [7377]	453 [4005]	333 [2944]	285 [2526]	10,7 [94.2]	39,4 [349]
DTR142-020	20:1	473 [4183]	432 [3824]	383 [3390]	833 [7377]	462 [4090]	363 [3210]	311 [2754]	10,8 [95.9]	40,9 [362]
DTR142-025	25:1	399 [3532]	399 [3532]	399 [3532]	833 [7377]	399 [3532]	388 [3432]	333 [2944]	10,6 [94.0]	40,9 [362]
DTR142-030	30:1	268 [2373]	228 [2022]	134 [1185]	833 [7377]	248 [2196]	211 [1871]	195 [1724]	11,7 [103]	35,6 [315]
DTR142-040	40:1	279 [2468]	240 [2122]	221 [1952]	833 [7377]	258 [2284]	221 [1955]	204 [1807]	10,8 [95.5]	35,6 [315]
DTR142-050	50:1	287 [2543]	247 [2183]	228 [2022]	833 [7377]	266 [2353]	228 [2020]	211 [1871]	10,6 [93.7]	35,6 [315]
DTR142-060	60:1	592 [5238]	429 [3794]	368 [3255]	833 [7377]	486 [4297]	348 [3082]	299 [2644]	13,8 [122]	40,8 [361]
DTR142-075	75:1	557 [4928]	493 [4362]	423 [3742]	833 [7377]	544 [4819]	400 [3542]	343 [3039]	11,7 [104]	40,6 [360]
DTR142-090	90:1	579 [5126]	484 [4286]	415 [3676]	833 [7377]	547 [4839]	393 [3480]	337 [2986]	11,8 [104]	38,6 [342]
DTR142-100	100:1	584 [5166]	473 [4183]	405 [3588]	833 [7377]	534 [4723]	384 [3397]	329 [2915]	13,7 [121]	40,2 [356]
DTR142-120	120:1	416 [3681]	416 [3681]	416 [3681]	798 [7062]	416 [3681]	416 [3681]	368 [3255]	10,9 [96.3]	39,0 [345]
DTR142-125	125:1	480 [4250]	480 [4250]	480 [4250]	833 [7377]	480 [4250]	467 [4129]	400 [3542]	10,6 [94.0]	40,9 [362]
DTR142-150	150:1	603 [5337]	534 [4723]	458 [4052]	833 [7377]	590 [5218]	433 [3836]	372 [3291]	11,7 [104]	40,6 [360]
DTR142-200	200:1	616 [5450]	563 [4983]	499 [4417]	833 [7377]	602 [5329]	473 [4183]	405 [3588]	13,6 [120]	40,8 [361]
DTR142-250	250:1	520 [4602]	520 [4602]	520 [4602]	833 [7377]	520 [4602]	505 [4472]	433 [3836]	10,6 [94.0]	40,9 [362]
DTR142-300	300:1	349 [3092]	298 [2635]	174 [1544]	833 [7377]	323 [2861]	275 [2438]	254 [2246]	11,7 [103]	35,6 [315]
DTR142-400	400:1	363 [3216]	312 [2765]	287 [2543]	833 [7377]	336 [2976]	288 [2547]	266 [2355]	10,8 [95.5]	35,6 [315]
DTR142-500	500:1	374 [3314]	321 [2844]	298 [2635]	833 [7377]	346 [3066]	297 [2632]	275 [2438]	10,1 [89.4]	35,6 [315]

¹ Ratios are exact, higher ratios and other custom options are also available, consult factory.
 T_r = Rated output torque at rated speed for specific hours of life.

T_{peak} = Allowable momentary peak torque for emergency stop or heavy shock loading
 J = Mass moment of inertia reflected to the input shaft (including pinion assembly).

DuraTRUE 90™ Size 142S (Slim Line)

Right Angle Gearheads

Metric

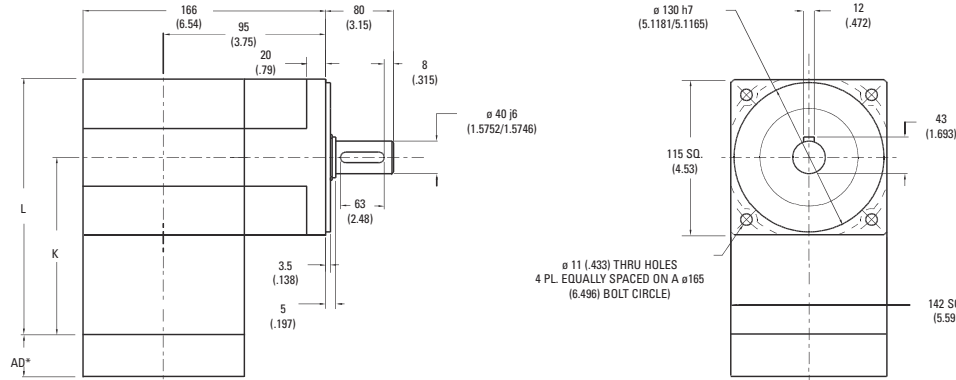

Ratio ¹	Dimension 'K' mm [in]	Dimension 'L' mm [in]	Backlash [arc-min]	Weight kg [lb]	Efficiency
1:1 to 5:1P	160 [6.29]	231 [9.09]	8 max	19 [43]	98%
5:1T to 50:1	209 [8.23]	280 [11.03]	9 max	24 [53]	93%
60:1 to 500:1	259 [10.18]	329 [12.97]	9 max	28 [62]	88%

All dimensions are: mm (inch)
 AD** = Adapter length
 Adapter length will vary depending on motor.
 Efficiency is calculated at 100% of the rated torque.

Performance Specifications

Part Number	Ratio ¹	10000 Hour Life			T _{peak} Nm [in-lb]	20000 Hour Life			J kg-cm ² [in-lb-sec ² x10 ⁻⁴]	Torsional Stiffness Nm/arc-min [in-lb/arc-min]
		T _r (1000 rpm) Nm [in-lb]	T _r (3000 rpm) Nm [in-lb]	T _r (5000 rpm) Nm [in-lb]		T _r (1000 rpm) Nm [in-lb]	T _r (3000 rpm) Nm [in-lb]	T _r (5000 rpm) Nm [in-lb]		
DTR142S-001	1:1	135 [1194]	123 [1090]	111 [985]	333 [2950]	125 [1103]	114 [1006]	103 [910]	26,3 [232]	23,7 [210]
DTR142S-002	2:1	279 [2474]	255 [2257]	231 [2041]	621 [5500]	258 [2284]	236 [2084]	213 [1885]	13,5 [119]	38,9 [344]
DTR142S-003	3:1	188 [1663]	171 [1518]	155 [1372]	478 [4230]	174 [1536]	158 [1401]	143 [1267]	11,6 [102]	44,1 [390]
DTR142S-004	4:1	135 [1194]	123 [1090]	111 [985]	414 [3660]	125 [1103]	114 [1006]	103 [910]	10,8 [95.1]	46,3 [410]
DTR142S-005P	5:1P	101 [896]	92 [818]	84 [739]	347 [3075]	93 [827]	85 [755]	77 [683]	10,6 [93.3]	47,4 [419]
DTR142S-005T	5:1T	340 [3009]	289 [2559]	281 [2484]	782 [6917]	333 [2944]	267 [2363]	259 [2294]	13,8 [122]	47,4 [419]
DTR142S-006	6:1	329 [2909]	279 [2474]	271 [2402]	678 [6000]	322 [2846]	258 [2284]	251 [2218]	13,8 [122]	31,8 [281]
DTR142S-009	9:1	221 [1956]	188 [1663]	182 [1614]	532 [4710]	216 [1913]	174 [1536]	168 [1491]	11,6 [102]	39,6 [351]
DTR142S-010	10:1	339 [2996]	309 [2735]	279 [2474]	734 [6500]	334 [2958]	296 [2621]	258 [2284]	13,1 [116]	31,6 [280]
DTR142S-012	12:1	159 [1404]	135 [1194]	131 [1159]	454 [4020]	155 [1374]	125 [1103]	121 [1071]	11,1 [97.7]	43,4 [384]
DTR142S-015	15:1	228 [2014]	208 [1839]	188 [1663]	551 [4875]	225 [1989]	199 [1762]	174 [1536]	10,9 [95.9]	45,4 [402]
DTR142S-020	20:1	163 [1446]	149 [1320]	135 [1194]	768 [6800]	161 [1428]	143 [1265]	125 [1103]	10,4 [91.5]	43,3 [383]
DTR142S-025	25:1	123 [1085]	112 [991]	101 [896]	391 [3460]	121 [1071]	107 [949]	93 [827]	10,2 [89.8]	45,3 [401]
DTR142S-030	30:1	233 [2058]	223 [1970]	213 [1882]	573 [5070]	231 [2045]	218 [1932]	205 [1819]	10,6 [93.8]	38,8 [343]
DTR142S-040	40:1	167 [1478]	160 [1415]	153 [1352]	486 [4300]	166 [1469]	157 [1387]	148 [1306]	10,1 [89.4]	42,8 [379]
DTR142S-050	50:1	125 [1109]	120 [1061]	115 [1014]	404 [3575]	125 [1102]	118 [1041]	111 [980]	9,91 [87.6]	45,0 [398]
DTR142S-060	60:1	351 [3105]	346 [3061]	341 [3018]	814 [7200]	350 [3099]	344 [3042]	337 [2986]	13,8 [122]	31,0 [274]
DTR142S-075	75:1	236 [2084]	232 [2049]	228 [2014]	593 [5250]	235 [2079]	230 [2034]	225 [1989]	11,1 [97.9]	39,4 [348]
DTR142S-090	90:1	236 [2087]	233 [2058]	229 [2029]	597 [5280]	235 [2083]	231 [2045]	227 [2008]	11,6 [103]	39,1 [346]
DTR142S-100	100:1	352 [3114]	349 [3088]	346 [3061]	825 [7300]	351 [3110]	348 [3076]	344 [3042]	13,1 [116]	31,3 [278]
DTR142S-120	120:1	169 [1499]	167 [1478]	165 [1457]	506 [4480]	169 [1496]	166 [1469]	163 [1442]	11,1 [98.2]	43,0 [380]
DTR142S-125	125:1	127 [1123]	125 [1104]	123 [1085]	415 [3675]	127 [1120]	124 [1096]	121 [1071]	10,4 [91.7]	45,3 [401]
DTR142S-150	150:1	237 [2093]	235 [2076]	233 [2058]	607 [5370]	236 [2091]	234 [2068]	231 [2045]	10,9 [96.4]	39,3 [348]
DTR142S-200	200:1	353 [3120]	351 [3107]	350 [3094]	842 [7450]	352 [3118]	350 [3101]	349 [3085]	12,9 [114]	30,5 [270]
DTR142S-250	250:1	127 [1128]	126 [1118]	125 [1109]	421 [3725]	127 [1126]	126 [1114]	125 [1102]	10,2 [90.3]	45,2 [400]
DTR142S-300	300:1	237 [2098]	236 [2089]	235 [2080]	614 [5430]	237 [2096]	236 [2085]	234 [2074]	10,7 [94.3]	38,8 [343]
DTR142S-400	400:1	170 [1506]	169 [1500]	169 [1494]	518 [4580]	170 [1505]	169 [1497]	168 [1489]	10,2 [89.8]	42,8 [379]
DTR142S-500	500:1	128 [1130]	127 [1125]	127 [1121]	427 [3775]	128 [1129]	127 [1123]	126 [1117]	9,96 [88.1]	45,0 [398]

Ratio 5P is designed using only PowerTRUE face gearing technology.
 Ratio 5T adds a True Planetary gearing stage for increased torque capacity.
¹ Ratios are exact, higher ratios and other custom options are also available, consult factory.

T_r = Rated output torque at rated speed for specific hours of life.
 J = Mass moment of inertia reflected to the input shaft (including pinion assembly)
 T_{peak} = Allowable momentary peak torque for emergency stop or heavy shock loading.

Radial and Axial Load Ratings

DTR60

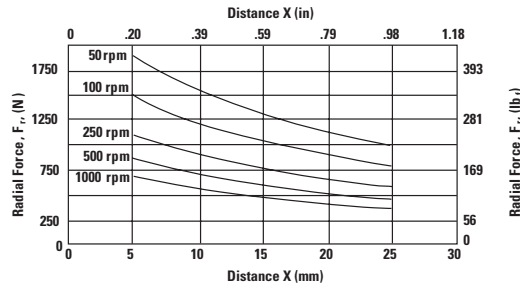
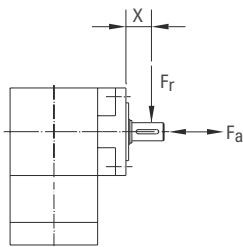

Speed rpm	Axial Load, F_a N [lb.]
50	3075 [692]
100	2441 [549]
250	1798 [405]
500	1427 [321]
1000	1133 [255]

DTR90

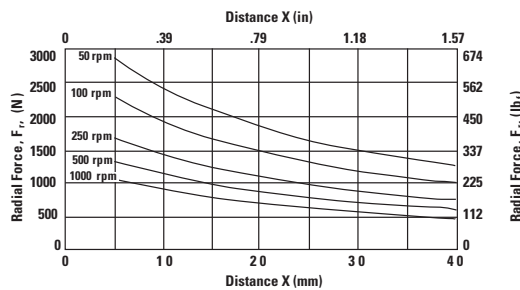
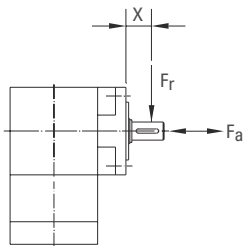

Speed rpm	Axial Load, F_a N [lb.]
50	4506 [1014]
100	3576 [805]
250	2635 [593]
500	2091 [471]
1000	1660 [373]

DTR115

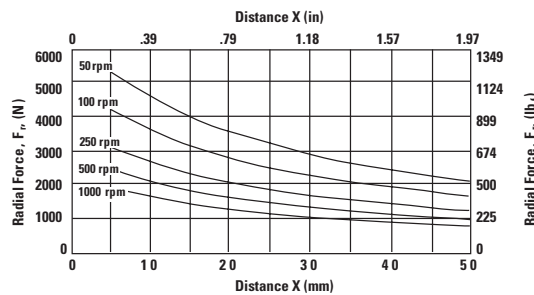
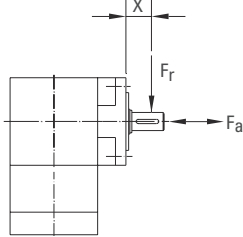

Speed rpm	Axial Load, F_a N [lb.]
50	8196 [1844]
100	6505 [1464]
250	4793 [1078]
500	3804 [856]
1000	3019 [679]

DTR142

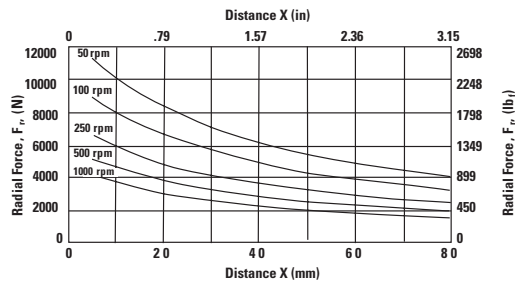
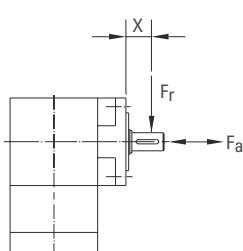

Speed rpm	Axial Load, F_a N [lb.]
50	17023 [3830]
100	13511 [3040]
250	9956 [2240]
500	7902 [1778]
1000	6271 [1411]

These graphs display the allowable radial load at a given distance (X) from the mounting surface based on an L_{10} life of 10,000 hours for the mean output speed n_{mout} , as described on page 10,

Radial and Axial Load Ratings

DTR60S

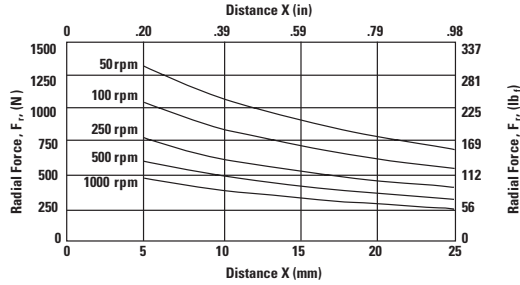
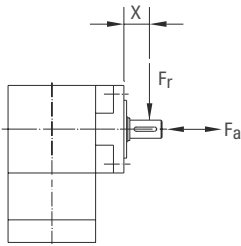

Speed rpm	Axial Load, F_a N [lb _f]
50	2155 [484]
100	1710 [384]
250	1260 [283]
500	1000 [225]
1000	794 [178]

DTR90S

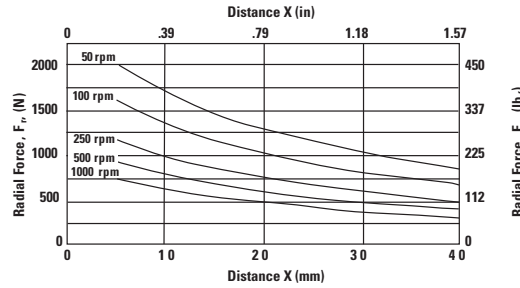
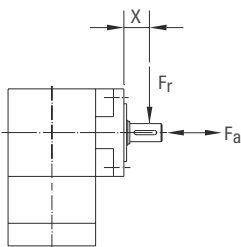

Speed rpm	Axial Load, F_a N [lb _f]
50	3157 [710]
100	2506 [563]
250	1846 [415]
500	1465 [329]
1000	1163 [261]

DuraTRUE 90™

DTR115S

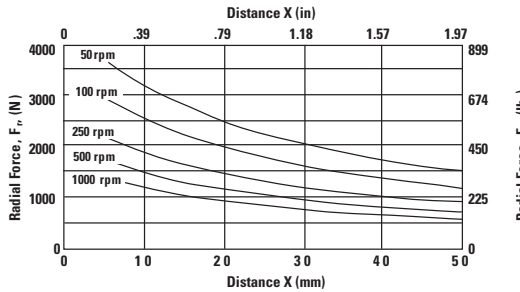
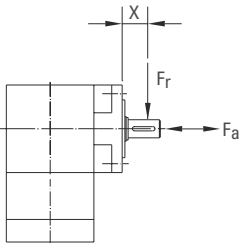

Speed rpm	Axial Load, F_a N [lb _f]
50	5742 [1291]
100	4558 [1025]
250	3358 [755]
500	2665 [599]
1000	2115 [476]

DTR142S

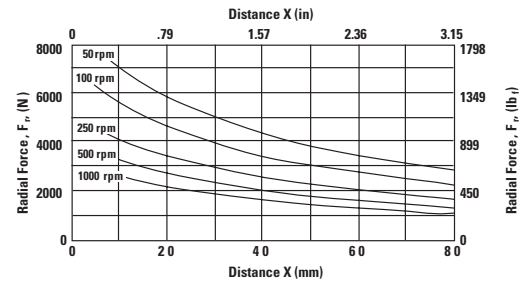
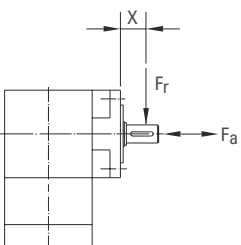

Speed rpm	Axial Load, F_a N [lb _f]
50	11925 [2681]
100	9465 [2128]
250	6974 [1568]
500	5535 [1244]
1000	4393 [988]

These graphs display the allowable radial load at a given distance (X) from the mounting surface based on an L₁₀ life of 10,000 hours for the mean output speed n_{mout} , as described on page 10,

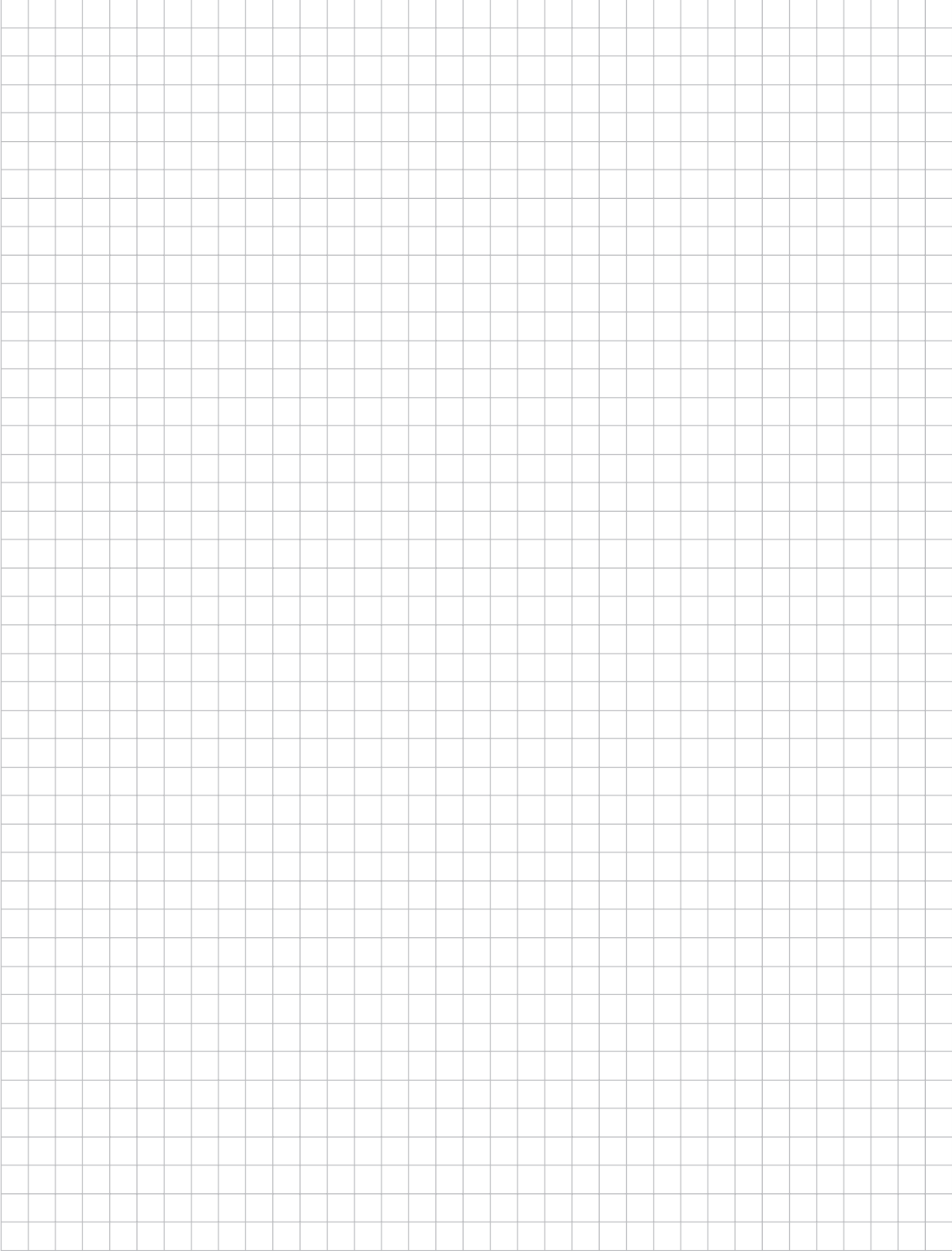

DuraTRUE 90™ Hollow Shaft

Right Angle Gearheads

Ready for Immediate Delivery	
Precision	8 arc-minutes
Frame Sizes	90mm, 115mm and 142mm
Torque Capacity	up to 865 Nm
Ratio Availability	1:1 thru 500:1
Radial load capacity	up to 11150 N
Mounting System	RediMount™

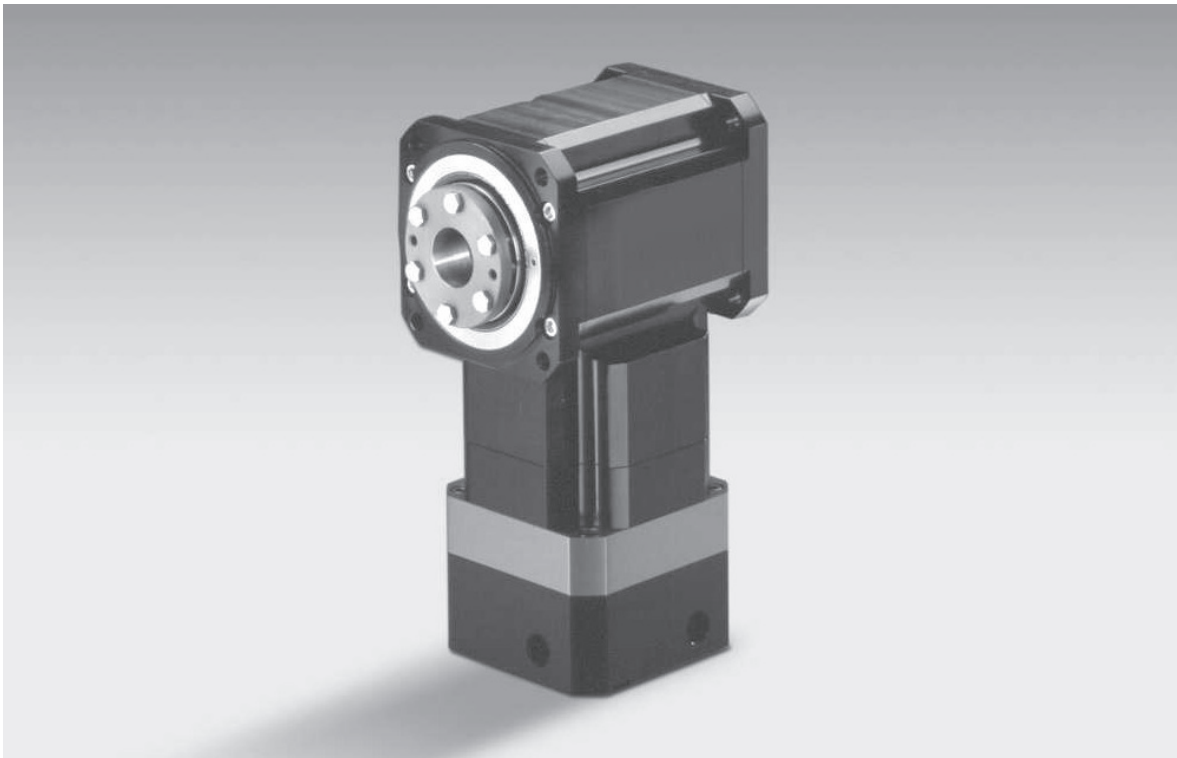

DuraTRUE 90™
Hollow & Dual

DuraTRUE 90™ Size 90H (Hollow Shaft)

Right Angle Gearheads

Metric

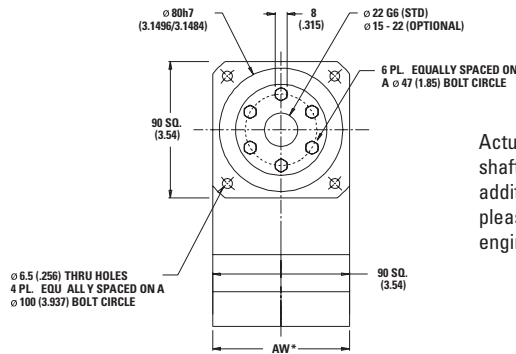
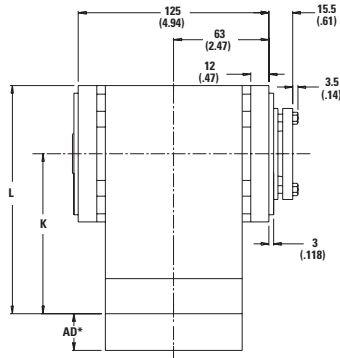

Actual thru bore of output shaft is larger than shown. For additional thru bore information, please contact application engineering.

Ratio ¹	Dimension 'K' mm [in]	Dimension 'L' mm [in]	Backlash [arc-min]	Weight kg [lb]	Efficiency
1:1 to 5:1P	101 [3.99]	146 [5.76]	8 max	4.1 [9]	98%
5:1T to 50:1	124 [4.89]	169 [6.66]	9 max	4.8 [10]	93%
60:1 to 500:1	147 [5.79]	192 [7.56]	9 max	5.5 [12]	88%

All dimensions are: mm (inch)
 AW* = Adapter width
 AD* = Adapter length
 Both will vary depending on motor.
 Efficiency is calculated at 100% of the rated torque.

Performance Specifications

Part Number	Ratio ¹	10,000 Hour Life			T _{peak} Nm [in-lb]	20,000 Hour Life			J kg-cm ² [in-lb-sec ² x10 ⁻⁴]	Torsional Stiffness Nm/arc-min [in-lb/arc-min]
		T _r (1000 rpm) Nm [in-lb]	T _r (3000 rpm) Nm [in-lb]	T _r (5000 rpm) Nm [in-lb]		T _r (1000 rpm) Nm [in-lb]	T _r (3000 rpm) Nm [in-lb]	T _r (5000 rpm) Nm [in-lb]		
DTR90H-001	1:1	21 [188]	19 [171]	17 [155]	140 [1237]	20 [173]	18 [158]	16 [143]	3,11 [27.5]	4,3 [37.9]
DTR90H-002	2:1	48 [426]	44 [389]	40 [352]	140 [1237]	44 [394]	41 [359]	37 [325]	1,59 [14.1]	6,5 [57.2]
DTR90H-003	3:1	32 [281]	29 [256]	26 [232]	140 [1237]	29 [260]	27 [237]	24 [214]	1,37 [12.1]	7,3 [64.6]
DTR90H-004	4:1	24 [215]	22 [196]	20 [177]	140 [1237]	22 [199]	20 [181]	19 [164]	1,27 [11.2]	7,6 [67.7]
DTR90H-005P	5:1P	18 [158]	16 [144]	15 [131]	140 [1237]	17 [146]	15 [133]	14 [121]	1,25 [11.0]	7,8 [69.2]
DTR90H-005T	5:1T	64 [568]	55 [483]	53 [469]	140 [1237]	63 [556]	50 [446]	49 [433]	1,64 [14.5]	5,1 [45.1]
DTR90H-006	6:1	57 [501]	48 [426]	47 [414]	140 [1237]	55 [490]	44 [394]	43 [382]	1,63 [14.4]	5,1 [45.1]
DTR90H-009	9:1	37 [331]	32 [281]	31 [273]	140 [1237]	37 [323]	29 [260]	28 [252]	1,37 [12.1]	6,4 [56.9]
DTR90H-010	10:1	58 [516]	53 [471]	48 [426]	140 [1237]	58 [510]	51 [452]	44 [394]	1,54 [13.7]	5,0 [44.5]
DTR90H-012	12:1	29 [253]	24 [215]	24 [209]	140 [1237]	28 [247]	22 [199]	22 [193]	1,31 [11.6]	7,1 [62.7]
DTR90H-015	15:1	38 [340]	35 [311]	32 [281]	140 [1237]	38 [336]	34 [298]	29 [260]	1,28 [11.3]	7,4 [65.8]
DTR90H-020	20:1	29 [261]	27 [238]	24 [215]	140 [1237]	29 [257]	26 [228]	22 [199]	1,22 [10.8]	7,1 [62.4]
DTR90H-025	25:1	22 [192]	20 [175]	18 [158]	140 [1237]	21 [189]	19 [168]	17 [146]	1,20 [10.6]	7,4 [65.6]
DTR90H-030	30:1	39 [348]	38 [333]	36 [318]	140 [1237]	39 [346]	37 [327]	35 [307]	1,25 [11.1]	6,1 [53.8]
DTR90H-040	40:1	30 [266]	29 [255]	28 [243]	140 [1237]	30 [265]	28 [250]	27 [235]	1,19 [10.6]	6,8 [60.5]
DTR90H-050	50:1	22 [196]	21 [188]	20 [179]	140 [1237]	22 [195]	21 [184]	20 [173]	1,17 [10.4]	7,3 [64.2]
DTR90H-060	60:1	60 [535]	60 [527]	59 [520]	140 [1237]	60 [534]	59 [524]	58 [514]	1,63 [14.4]	4,9 [43.5]
DTR90H-075	75:1	40 [352]	39 [346]	38 [340]	140 [1237]	40 [351]	39 [344]	38 [336]	1,31 [11.6]	6,4 [56.2]
DTR90H-090	90:1	40 [353]	39 [348]	39 [343]	140 [1237]	40 [352]	39 [346]	38 [339]	1,37 [12.1]	6,3 [55.8]
DTR90H-100	100:1	61 [536]	60 [532]	60 [527]	140 [1237]	61 [536]	60 [530]	59 [524]	1,55 [13.7]	5,0 [43.9]
DTR90H-120	120:1	31 [270]	30 [266]	30 [262]	140 [1237]	30 [269]	30 [265]	29 [260]	1,31 [11.6]	7,0 [62.0]
DTR90H-125	125:1	22 [198]	22 [195]	22 [192]	140 [1237]	22 [198]	22 [194]	21 [189]	1,23 [10.8]	7,4 [65.5]
DTR90H-150	150:1	40 [354]	40 [351]	39 [348]	140 [1237]	40 [353]	39 [350]	39 [346]	1,29 [11.4]	6,3 [56.1]
DTR90H-200	200:1	61 [538]	60 [535]	60 [533]	140 [1237]	61 [537]	60 [534]	60 [531]	1,52 [13.5]	4,6 [40.7]
DTR90H-250	250:1	23 [199]	22 [198]	22 [196]	140 [1237]	22 [199]	22 [197]	22 [195]	1,21 [10.7]	7,4 [65.4]
DTR90H-300	300:1	40 [355]	40 [353]	40 [352]	140 [1237]	40 [354]	40 [352]	40 [350]	1,26 [11.1]	6,1 [53.7]
DTR90H-400	400:1	31 [271]	31 [270]	30 [269]	140 [1237]	31 [271]	30 [270]	30 [268]	1,20 [10.6]	6,8 [60.5]
DTR90H-500	500:1	23 [200]	22 [199]	22 [198]	140 [1237]	23 [200]	22 [198]	22 [197]	1,18 [10.4]	7,3 [64.2]

Ratio 5P is designed using only PowerTRUE face gearing technology.
 Ratio 5T adds a True Planetary gearing stage for increased torque capacity.
¹ Ratios are exact, higher ratios are also available, consult factory.

T_r = Rated output torque at rated speed for specific hours of life.
 J = Mass moment of inertia reflected to the input shaft (including pinion assembly)
 T_{peak} = Allowable momentary peak torque for emergency stop or heavy shock loading.

DuraTRUE 90™ Size 115H (Hollow Shaft)

Right Angle Gearheads

Metric

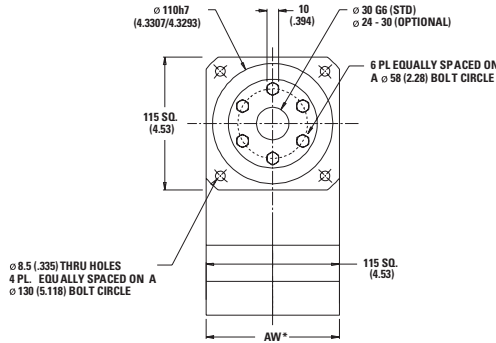
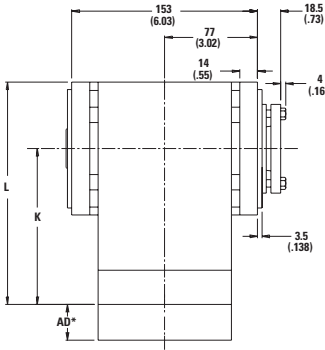

Actual thru bore of output shaft is larger than shown. For additional thru bore information, please contact application engineering.

Ratio ¹	Dimension 'K' mm [in]	Dimension 'L' mm [in]	Backlash [arc-min]	Weight kg [lb]	Efficiency
1:1 to 5:1P	137 [5.41]	195 [7.67]	8 max	9 [20]	98%
5:1T to 50:1	169 [6.64]	226 [8.90]	9 max	11 [24]	93%
60:1 to 500:1	200 [7.87]	257 [10.13]	9 max	12 [27]	88%

All dimensions are: mm (inch)
 AW* = Adapter width
 AD* = Adapter length
 Both will vary depending on motor.
 Efficiency is calculated at 100% of the rated torque.

Performance Specifications

Part Number	Ratio ¹	10,000 Hour Life				T peak Nm [in-lb]	20,000 Hour Life			J kg-cm ² [in-lb-sec ² x10 ⁻⁴]	Torsional Stiffness Nm/arc-min [in-lb/arc-min]
		T _r (1000 rpm) Nm [in-lb]	T _r (3000 rpm) Nm [in-lb]	T _r (5000 rpm) Nm [in-lb]	T _r (1000 rpm) Nm [in-lb]		T _r (3000 rpm) Nm [in-lb]	T _r (5000 rpm) Nm [in-lb]			
DTR115H-001	1:1	63 [554]	57 [506]	52 [457]	283 [2505]	58 [512]	53 [467]	48 [422]	5,28 [46.7]	7,6 [67.6]	
DTR115H-002	2:1	112 [989]	102 [903]	92 [816]	283 [2505]	103 [913]	94 [834]	85 [754]	2,71 [23.9]	12,5 [111]	
DTR115H-003	3:1	87 [768]	79 [701]	72 [634]	283 [2505]	80 [709]	73 [647]	66 [585]	2,33 [20.6]	14,2 [126]	
DTR115H-004	4:1	58 [511]	53 [467]	48 [422]	283 [2505]	53 [472]	49 [431]	44 [390]	2,16 [19.1]	14,9 [132]	
DTR115H-005P	5:1P	43 [384]	40 [350]	36 [316]	283 [2505]	40 [354]	37 [323]	33 [292]	2,12 [18.8]	15,3 [135]	
DTR115H-005T	5:1T	170 [1505]	126 [1117]	108 [958]	283 [2505]	143 [1262]	102 [907]	88 [778]	2,78 [24.6]	15,3 [135]	
DTR115H-006	6:1	131 [1163]	112 [989]	109 [960]	283 [2505]	129 [1138]	103 [913]	100 [887]	2,77 [24.5]	10,2 [90.7]	
DTR115H-009	9:1	102 [903]	87 [768]	84 [746]	283 [2505]	100 [884]	80 [709]	78 [689]	2,32 [20.5]	12,8 [113]	
DTR115H-010	10:1	135 [1198]	124 [1094]	112 [989]	283 [2505]	134 [1183]	118 [1048]	103 [913]	2,63 [23.2]	10,2 [90.3]	
DTR115H-012	12:1	68 [601]	58 [511]	56 [496]	283 [2505]	66 [588]	53 [472]	52 [458]	2,22 [19.6]	14,0 [124]	
DTR115H-015	15:1	105 [930]	96 [849]	87 [768]	283 [2505]	104 [919]	92 [814]	80 [709]	2,18 [19.3]	14,6 [130]	
DTR115H-020	20:1	70 [619]	64 [565]	58 [511]	283 [2505]	69 [612]	61 [542]	53 [472]	2,08 [18.4]	14,0 [124]	
DTR115H-025	25:1	52 [465]	48 [424]	43 [384]	283 [2505]	52 [459]	46 [406]	40 [354]	2,04 [18.0]	14,6 [129]	
DTR115H-030	30:1	107 [951]	103 [910]	98 [869]	283 [2505]	107 [945]	101 [892]	95 [840]	2,13 [18.9]	12,5 [111]	
DTR115H-040	40:1	72 [633]	68 [606]	65 [579]	283 [2505]	71 [629]	67 [594]	63 [559]	2,03 [18.0]	13,8 [122]	
DTR115H-050	50:1	54 [475]	51 [454]	49 [434]	283 [2505]	53 [472]	50 [446]	47 [419]	1,99 [17.6]	14,5 [128]	
DTR115H-060	60:1	140 [1242]	138 [1224]	136 [1207]	283 [2505]	140 [1239]	137 [1217]	135 [1194]	2,78 [24.6]	10,0 [88.5]	
DTR115H-075	75:1	109 [963]	107 [947]	105 [930]	283 [2505]	109 [960]	106 [939]	104 [919]	2,22 [19.7]	12,7 [112]	
DTR115H-090	90:1	109 [964]	107 [951]	106 [937]	283 [2505]	109 [962]	107 [945]	105 [927]	2,33 [20.6]	12,6 [112]	
DTR115H-100	100:1	141 [1245]	140 [1235]	138 [1224]	283 [2505]	141 [1244]	137 [1230]	137 [1217]	2,64 [23.3]	10,1 [89.5]	
DTR115H-120	120:1	73 [642]	72 [633]	70 [624]	283 [2505]	72 [641]	70 [629]	70 [617]	2,23 [19.7]	13,9 [123]	
DTR115H-125	125:1	54 [481]	53 [473]	52 [465]	283 [2505]	54 [480]	52 [469]	52 [459]	2,08 [18.4]	14,6 [129]	
DTR115H-150	150:1	109 [967]	108 [959]	107 [951]	283 [2505]	109 [966]	107 [955]	107 [945]	2,19 [19.4]	12,7 [112]	
DTR115H-200	200:1	141 [1248]	140 [1243]	140 [1237]	283 [2505]	141 [1247]	139 [1240]	138 [1234]	2,59 [22.9]	9,8 [87.1]	
DTR115H-250	250:1	55 [483]	54 [479]	54 [475]	283 [2505]	54 [482]	53 [477]	53 [472]	2,05 [18.1]	14,6 [129]	
DTR115H-300	300:1	109 [969]	109 [965]	109 [961]	283 [2505]	109 [968]	108 [963]	108 [958]	2,14 [18.9]	12,5 [111]	
DTR115H-400	400:1	73 [645]	73 [642]	72 [640]	283 [2505]	73 [645]	72 [641]	72 [638]	2,04 [18.1]	13,8 [122]	
DTR115H-500	500:1	55 [484]	54 [482]	54 [480]	283 [2505]	55 [483]	54 [481]	54 [478]	2,00 [17.7]	14,5 [128]	

Ratio 5P is designed using only PowerTRUE face gearing technology.
 Ratio 5T adds a True Planetary gearing stage for increased torque capacity.
¹ Ratios are exact, higher ratios are also available, consult factory.

T_r = Rated output torque at rated speed for specific hours of life.
 J = Mass moment of inertia reflected to the input shaft (including pinion assembly)
 T_{peak} = Allowable momentary peak torque for emergency stop or heavy shock loading.

DuraTRUE 90™ Size 142H (Hollow Shaft)

Right Angle Gearheads

Metric

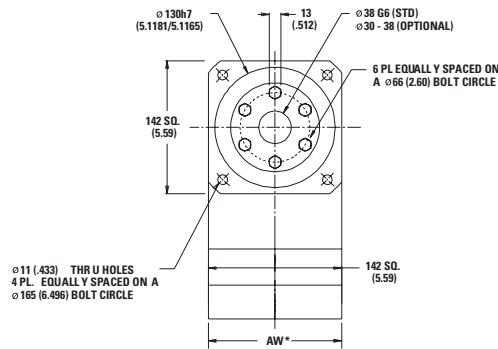
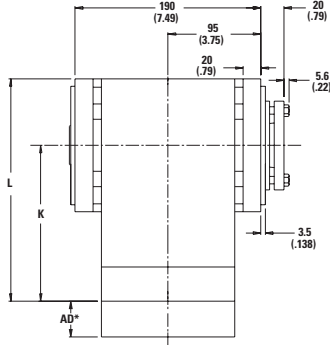

Actual thru bore of output shaft is larger than shown. For additional thru bore information, please contact application engineering.

Ratio ¹	Dimension 'K' mm [in]	Dimension 'L' mm [in]	Backlash [arc-min]	Weight kg [lb]	Efficiency
1:1 to 5:1P	163 [6.43]	234 [9.22]	8 max	19 [43]	98%
5:1T to 50:1	233 [9.17]	304 [11.96]	9 max	24 [53]	93%
60:1 to 500:1	262 [10.3]	332 [13.10]	9 max	28 [62]	88%

All dimensions are: mm (inch)
 AW* = Adapter width
 AD* = Adapter length
 Both will vary depending on motor.
 Efficiency is calculated at 100% of the rated torque.

Performance Specifications

Part Number	Ratio ¹	10,000 Hour Life			T peak Nm [in-lb]	20,000 Hour Life			J kg-cm ² [in-lb-sec ² x10 ⁻⁴]	Torsional Stiffness Nm/arc-min [in-lb/arc-min]
		T _r (1000 rpm) Nm [in-lb]	T _r (3000 rpm) Nm [in-lb]	T _r (5000 rpm) Nm [in-lb]		T _r (1000 rpm) Nm [in-lb]	T _r (3000 rpm) Nm [in-lb]	T _r (5000 rpm) Nm [in-lb]		
DTR142H-001	1:1	135 [1194]	123 [1090]	111 [985]	865 [7659]	125 [1103]	114 [1006]	103 [910]	26.3 [232]	23.7 [210]
DTR142H-002	2:1	279 [2474]	255 [2257]	231 [2041]	865 [7659]	258 [2284]	236 [2084]	213 [1885]	13.5 [119]	38.9 [344]
DTR142H-003	3:1	188 [1663]	171 [1518]	155 [1372]	865 [7659]	174 [1536]	158 [1401]	143 [1267]	11.6 [102]	44.1 [390]
DTR142H-004	4:1	135 [1194]	123 [1090]	111 [985]	865 [7659]	125 [1103]	114 [1006]	103 [910]	10.8 [95.1]	46.3 [410]
DTR142H-005P	5:1P	101 [896]	92 [818]	84 [739]	865 [7659]	93 [827]	85 [755]	77 [683]	10.6 [93.3]	47.4 [419]
DTR142H-005T	5:1T	340 [3009]	289 [2559]	281 [2484]	865 [7659]	333 [2944]	267 [2363]	259 [2294]	13.8 [122]	47.4 [419]
DTR142H-006	6:1	329 [2909]	279 [2474]	271 [2402]	865 [7659]	322 [2846]	258 [2284]	251 [2218]	13.8 [122]	31.8 [281]
DTR142H-009	9:1	221 [1956]	188 [1663]	182 [1614]	865 [7659]	216 [1913]	174 [1536]	168 [1491]	11.6 [102]	39.6 [351]
DTR142H-010	10:1	339 [2996]	309 [2735]	279 [2474]	865 [7659]	334 [2958]	296 [2621]	258 [2284]	13.1 [116]	31.6 [280]
DTR142H-012	12:1	159 [1404]	135 [1194]	131 [1159]	865 [7659]	155 [1374]	125 [1103]	121 [1071]	11.1 [97.7]	43.4 [384]
DTR142H-015	15:1	228 [2014]	208 [1839]	188 [1663]	865 [7659]	225 [1989]	199 [1762]	174 [1536]	10.9 [95.9]	45.4 [402]
DTR142H-020	20:1	163 [1446]	149 [1320]	135 [1194]	865 [7659]	161 [1428]	143 [1265]	125 [1103]	10.4 [91.5]	43.3 [383]
DTR142H-025	25:1	123 [1085]	112 [991]	101 [896]	865 [7659]	121 [1071]	107 [949]	93 [827]	10.2 [89.8]	45.3 [401]
DTR142H-030	30:1	233 [2058]	223 [1970]	213 [1882]	865 [7659]	231 [2045]	218 [1932]	205 [1819]	10.6 [93.8]	38.8 [343]
DTR142H-040	40:1	167 [1478]	160 [1415]	153 [1352]	865 [7659]	166 [1469]	157 [1387]	148 [1306]	10.1 [89.4]	42.8 [379]
DTR142H-050	50:1	125 [1109]	120 [1061]	115 [1014]	865 [7659]	125 [1102]	118 [1041]	111 [980]	9.91 [87.6]	45.0 [398]
DTR142H-060	60:1	351 [3105]	346 [3061]	341 [3018]	865 [7659]	350 [3099]	344 [3042]	337 [2986]	13.8 [122]	31.0 [274]
DTR142H-075	75:1	236 [2084]	232 [2049]	228 [2014]	865 [7659]	235 [2079]	230 [2034]	225 [1989]	11.1 [97.9]	39.4 [348]
DTR142H-090	90:1	236 [2087]	233 [2058]	229 [2029]	865 [7659]	235 [2083]	231 [2045]	227 [2008]	11.6 [103]	39.1 [346]
DTR142H-100	100:1	352 [3114]	349 [3088]	346 [3061]	865 [7659]	351 [3110]	348 [3076]	344 [3042]	13.1 [116]	31.3 [278]
DTR142H-120	120:1	169 [1499]	167 [1478]	165 [1457]	865 [7659]	169 [1496]	166 [1469]	163 [1442]	11.1 [98.2]	43.0 [380]
DTR142H-125	125:1	127 [1123]	125 [1104]	123 [1085]	865 [7659]	127 [1120]	124 [1096]	121 [1071]	10.4 [91.7]	45.3 [401]
DTR142H-150	150:1	237 [2093]	235 [2076]	233 [2058]	865 [7659]	236 [2091]	234 [2068]	231 [2045]	10.9 [96.4]	39.3 [348]
DTR142H-200	200:1	353 [3120]	351 [3107]	350 [3094]	865 [7659]	352 [3118]	350 [3101]	349 [3085]	12.9 [114]	30.5 [270]
DTR142H-250	250:1	127 [1128]	126 [1118]	125 [1109]	865 [7659]	127 [1126]	126 [1114]	125 [1102]	10.2 [90.3]	45.2 [400]
DTR142H-300	300:1	237 [2098]	236 [2089]	235 [2080]	865 [7659]	237 [2096]	236 [2085]	234 [2074]	10.7 [94.3]	38.8 [343]
DTR142H-400	400:1	170 [1506]	169 [1500]	169 [1494]	865 [7659]	170 [1505]	169 [1497]	168 [1489]	10.2 [89.8]	42.8 [379]
DTR142H-500	500:1	128 [1130]	127 [1125]	127 [1121]	865 [7659]	128 [1129]	127 [1123]	126 [1117]	9.96 [88.1]	45.0 [398]

Ratio 5P is designed using only PowerTRUE face gearing technology.
 Ratio 5T adds a True Planetary gearing stage for increased torque capacity.
¹ Ratios are exact, higher ratios are also available, consult factory.

T_r = Rated output torque at rated speed for specific hours of life.
 J = Mass moment of inertia reflected to the input shaft (including pinion assembly)
 T_{peak} = Allowable momentary peak torque for emergency stop or heavy shock loading.

Radial and Axial Load Ratings

DTR90H

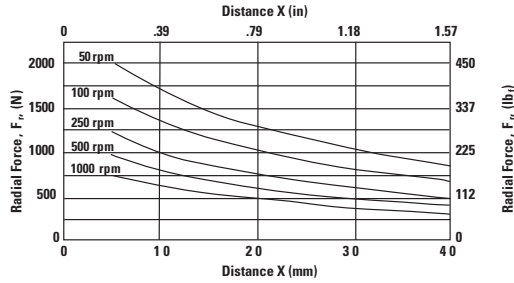
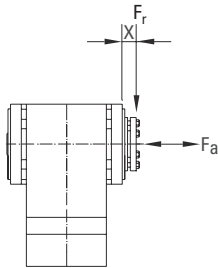

Speed rpm	Axial Load, F_a N [lb _f]
50	3157 [710]
100	2506 [563]
250	1846 [415]
500	1465 [329]
1000	1163 [261]

DTR115H

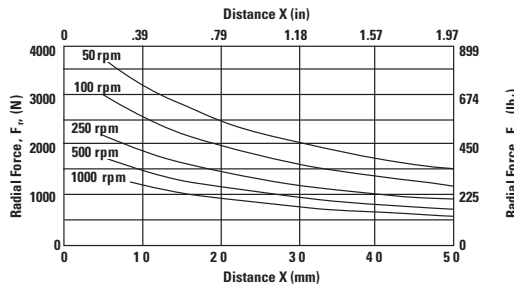
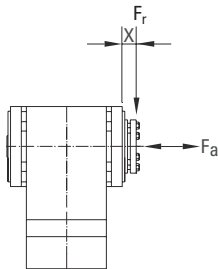

Speed rpm	Axial Load, F_a N [lb _f]
50	5742 [1291]
100	4558 [1025]
250	3358 [755]
500	2665 [599]
1000	2115 [476]

DTR142H

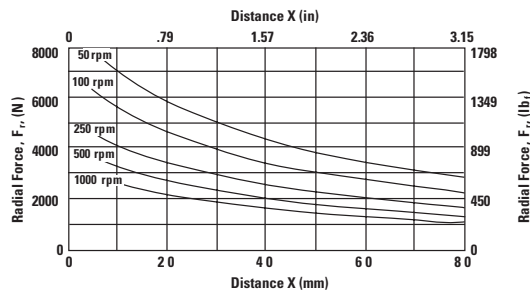
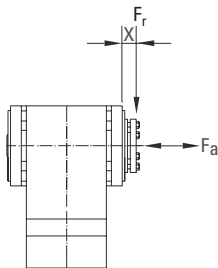

Speed rpm	Axial Load, F_a N [lb _f]
50	11925 [2681]
100	9465 [2128]
250	6974 [1568]
500	5535 [1244]
1000	4393 [988]

These graphs display the allowable radial load at a given distance (X) from the mounting surface based on an L₁₀ life of 10,000 hours for the mean output speed n_{mout} , as described on page 10.

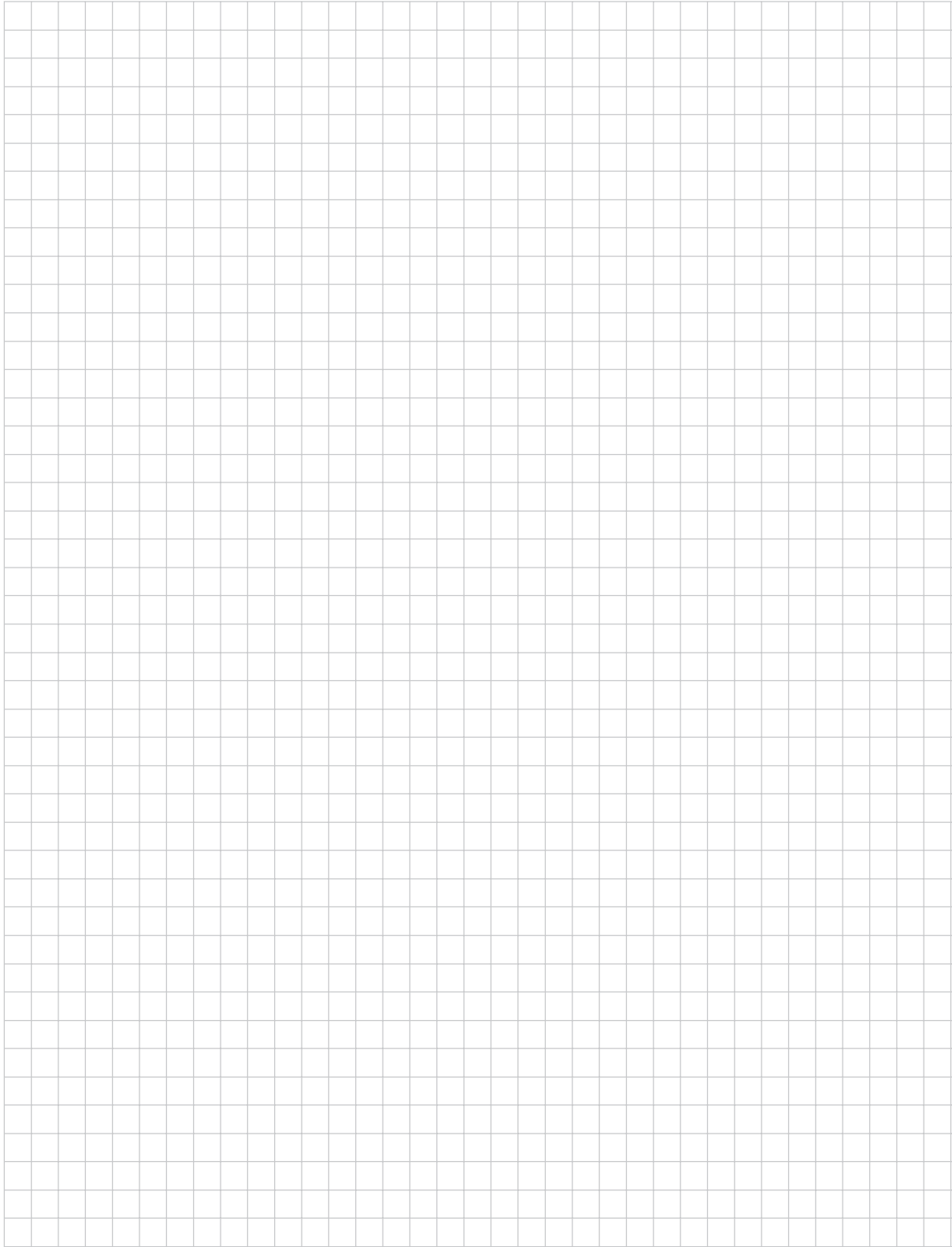

DuraTRUE 90™ Dual Shaft

Right Angle Gearheads

Ready for Immediate Delivery	
Precision	8 arc-minutes
Frame Sizes	60mm, 90mm, 115mm and 142mm
Torque Capacity	up to 865 Nm
Ratio Availability	1:1 thru 500:1
Radial load capacity	up to 11150 N
Mounting System	RediMount™

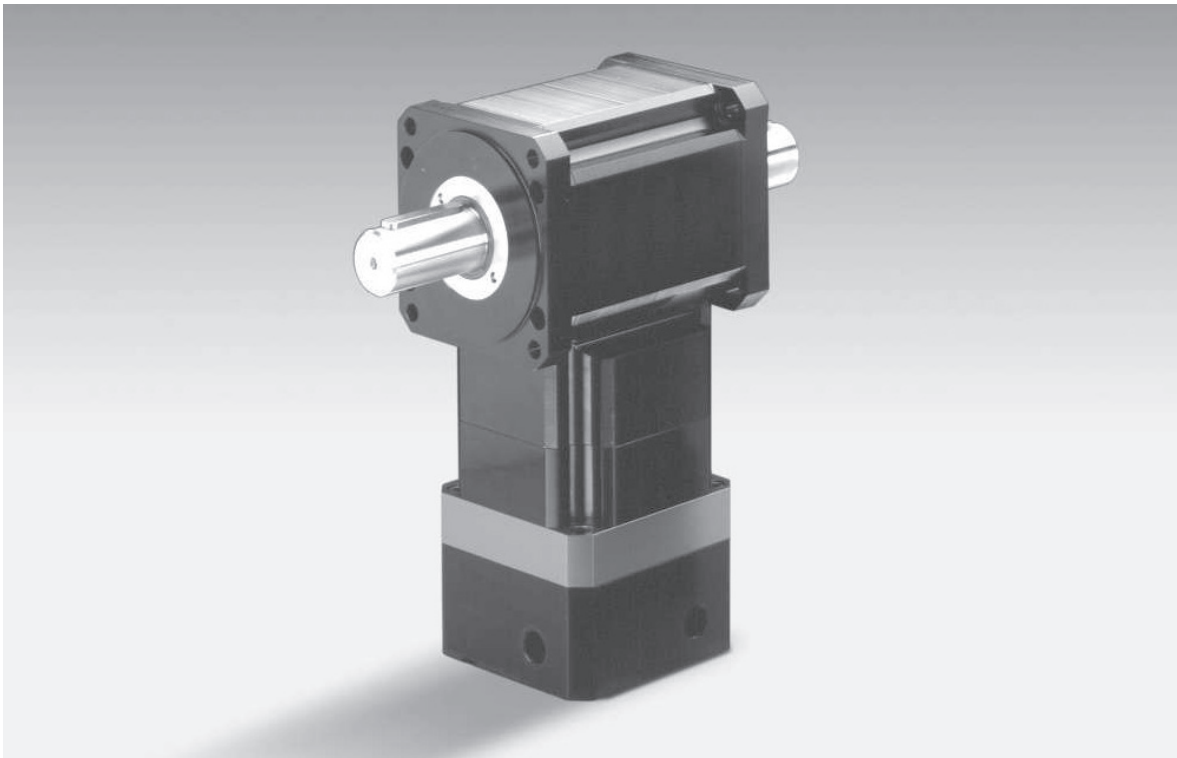

DuraTRUE 90™
Hollow & Dual

DuraTRUE 90™ Size 60D (Dual Shaft)

Right Angle Gearheads

Metric

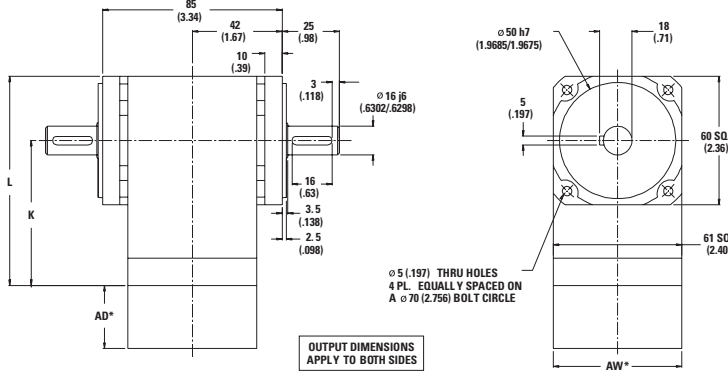

Ratio ¹	Dimension 'K' mm [in]	Dimension 'L' mm [in]	Backlash [arc-min]	Weight kg [lb]	Efficiency
1:1 to 5:1P	80 [3.15]	110 [4.33]	8 max	2,3 [5]	98%
5:1T to 50:1	97 [3.83]	127 [5.01]	9 max	2,5 [5.5]	93%
60:1 to 500:1	115 [4.52]	145 [5.70]	9 max	2,7 [6]	88%

All dimensions are: mm (inch)
 AW* = Adapter width
 AD* = Adapter length
 Both will vary depending on motor.
 Efficiency is calculated at 100% of the rated torque.

Performance Specifications

Part Number	Ratio ¹	10,000 Hour Life			T peak Nm [in-lb]	20,000 Hour Life			J kg-cm ² [in-lb-sec ² ×10 ⁻⁴]	Torsional Stiffness Nm/arc-min [in-lb/arc-min]
		T _r (1000 rpm) Nm [in-lb]	T _r (3000 rpm) Nm [in-lb]	T _r (5000 rpm) Nm [in-lb]		T _r (1000 rpm) Nm [in-lb]	T _r (3000 rpm) Nm [in-lb]	T _r (5000 rpm) Nm [in-lb]		
DTR60D-001	1:1	7 [66]	7 [60]	6 [54]	46 [407]	7 [61]	6 [56]	6 [50]	,79 [7.0]	1,8 [15.8]
DTR60D-002	2:1	16 [145]	15 [132]	14 [120]	46 [407]	15 [134]	14 [122]	12 [111]	,41 [3.6]	2,7 [23.8]
DTR60D-003	3:1	10 [92]	10 [84]	9 [76]	46 [407]	10 [85]	9 [78]	8 [70]	,35 [3.1]	3,0 [26.9]
DTR60D-004	4:1	8 [68]	7 [62]	6 [56]	46 [407]	7 [63]	6 [57]	6 [52]	,32 [2.9]	3,2 [28.2]
DTR60D-005P	5:1P	6 [56]	6 [51]	5 [46]	46 [407]	6 [52]	5 [47]	5 [43]	,32 [2.8]	3,3 [28.8]
DTR60D-005T	5:1T	23 [200]	18 [162]	16 [138]	46 [407]	21 [182]	15 [132]	13 [112]	,42 [3.7]	3,3 [28.8]
DTR60D-006	6:1	19 [171]	16 [145]	16 [141]	46 [407]	19 [167]	15 [134]	15 [130]	,41 [3.7]	2,1 [18.8]
DTR60D-009	9:1	12 [109]	10 [92]	10 [90]	46 [407]	12 [106]	10 [85]	9 [83]	,35 [3.1]	2,7 [23.7]
DTR60D-010	10:1	20 [176]	18 [160]	16 [145]	46 [407]	20 [174]	17 [154]	15 [134]	,39 [3.5]	2,1 [18.5]
DTR60D-012	12:1	9 [80]	8 [68]	7 [66]	46 [407]	9 [78]	7 [63]	7 [61]	,33 [3.0]	3,0 [26.1]
DTR60D-015	15:1	13 [112]	12 [102]	10 [92]	46 [407]	12 [110]	11 [98]	10 [85]	,33 [2.9]	3,1 [27.4]
DTR60D-020	20:1	9 [82]	8 [75]	8 [68]	46 [407]	9 [81]	8 [72]	7 [63]	,31 [2.8]	2,9 [26.0]
DTR60D-025	25:1	8 [68]	7 [62]	6 [56]	46 [407]	8 [67]	7 [59]	6 [52]	,31 [2.7]	3,1 [27.3]
DTR60D-030	30:1	13 [114]	12 [109]	12 [105]	46 [407]	13 [114]	12 [107]	11 [101]	,32 [2.8]	2,5 [22.4]
DTR60D-040	40:1	10 [84]	9 [81]	9 [77]	46 [407]	9 [84]	9 [79]	8 [74]	,30 [2.7]	2,8 [25.2]
DTR60D-050	50:1	8 [69]	7 [66]	7 [63]	46 [407]	8 [69]	7 [65]	7 [61]	,30 [2.6]	3,0 [26.8]
DTR60D-060	60:1	21 [182]	20 [180]	20 [177]	46 [407]	21 [182]	20 [178]	20 [175]	,42 [3.7]	2,0 [18.1]
DTR60D-075	75:1	13 [116]	13 [114]	13 [112]	46 [407]	13 [115]	13 [113]	12 [110]	,33 [3.0]	2,6 [23.4]
DTR60D-090	90:1	13 [116]	13 [114]	13 [113]	46 [407]	13 [116]	13 [114]	13 [111]	,35 [3.1]	2,6 [23.3]
DTR60D-100	100:1	21 [183]	20 [181]	20 [180]	46 [407]	21 [182]	20 [180]	20 [178]	,40 [3.5]	2,1 [18.3]
DTR60D-120	120:1	10 [85]	10 [84]	9 [83]	46 [407]	10 [85]	9 [84]	9 [82]	,33 [3.0]	2,9 [25.8]
DTR60D-125	125:1	8 [70]	8 [69]	8 [68]	46 [407]	8 [70]	8 [68]	8 [67]	,31 [2.8]	3,1 [27.3]
DTR60D-150	150:1	13 [116]	13 [115]	13 [114]	46 [407]	13 [116]	13 [115]	13 [114]	,33 [2.9]	2,6 [23.4]
DTR60D-200	200:1	21 [183]	21 [182]	21 [181]	46 [407]	21 [183]	21 [182]	20 [181]	,39 [3.4]	1,9 [17.0]
DTR60D-250	250:1	8 [70]	8 [70]	8 [69]	46 [407]	8 [70]	8 [69]	8 [69]	,31 [2.7]	3,1 [27.3]
DTR60D-300	300:1	13 [116]	13 [116]	13 [115]	46 [407]	13 [116]	13 [116]	13 [115]	,32 [2.8]	2,5 [22.4]
DTR60D-400	400:1	10 [86]	10 [85]	10 [85]	46 [407]	10 [86]	10 [85]	10 [85]	,31 [2.7]	2,8 [25.2]
DTR60D-500	500:1	8 [70]	8 [70]	8 [70]	46 [407]	8 [70]	8 [70]	8 [70]	,30 [2.7]	3,0 [26.8]

Ratio 5P is designed using only PowerTRUE face gearing technology.
 Ratio 5T adds a True Planetary gearing stage for increased torque capacity.
¹ Ratios are exact, higher ratios are also available, consult factory.

T_r = Rated output torque at rated speed for specific hours of life.
 J = Mass moment of inertia reflected to the input shaft (including pinion assembly)
 T_{peak} = Allowable momentary peak torque for emergency stop or heavy shock loading.

DuraTRUE 90™ Size 90D (Dual Shaft)

Right Angle Gearheads

Metric

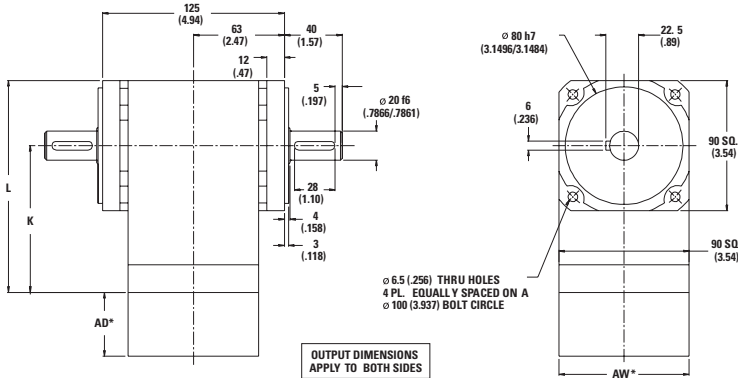

Ratio ¹	Dimension 'K' mm [in]	Dimension 'L' mm [in]	Backlash [arc-min]	Weight kg [lb]	Efficiency
1:1 to 5:1P	101 [3.99]	146 [5.76]	8 max	4,1 [9]	98%
5:1T to 50:1	124 [4.89]	169 [6.66]	9 max	4,8 [10]	93%
60:1 to 500:1	147 [5.79]	192 [7.56]	9 max	5,5 [12]	88%

All dimensions are: mm (inch)
 AW* = Adapter width
 AD* = Adapter length
 Both will vary depending on motor.
 Efficiency is calculated at 100% of the rated torque.

Performance Specifications

Part Number	Ratio ¹	10,000 Hour Life			T peak Nm [in-lb]	20,000 Hour Life			J kg-cm ² [in-lb-sec ² x10 ⁻⁴]	Torsional Stiffness Nm/arc-min [in-lb/arc-min]
		T _r (1000 rpm) Nm [in-lb]	T _r (3000 rpm) Nm [in-lb]	T _r (5000 rpm) Nm [in-lb]		T _r (1000 rpm) Nm [in-lb]	T _r (3000 rpm) Nm [in-lb]	T _r (5000 rpm) Nm [in-lb]		
DTR90D-001	1:1	21 [188]	19 [171]	17 [155]	140 [1237]	20 [173]	18 [158]	16 [143]	3,11 [27.5]	4,3 [37.9]
DTR90D-002	2:1	48 [426]	44 [389]	40 [352]	140 [1237]	44 [394]	41 [359]	37 [325]	1,59 [14.1]	6,5 [57.2]
DTR90D-003	3:1	32 [281]	29 [256]	26 [232]	140 [1237]	29 [260]	27 [237]	24 [214]	1,37 [12.1]	7,3 [64.6]
DTR90D-004	4:1	24 [215]	22 [196]	20 [177]	140 [1237]	22 [199]	20 [181]	19 [164]	1,27 [11.2]	7,6 [67.7]
DTR90D-005P	5:1P	18 [158]	16 [144]	15 [131]	140 [1237]	17 [146]	15 [133]	14 [121]	1,25 [11.0]	7,8 [69.2]
DTR90D-005T	5:1T	64 [568]	55 [483]	53 [469]	140 [1237]	63 [556]	50 [446]	49 [433]	1,64 [14.5]	5,1 [45.1]
DTR90D-006	6:1	57 [501]	48 [426]	47 [414]	140 [1237]	55 [490]	44 [394]	43 [382]	1,63 [14.4]	5,1 [45.1]
DTR90D-009	9:1	37 [331]	32 [281]	31 [273]	140 [1237]	37 [323]	29 [260]	28 [252]	1,37 [12.1]	6,4 [56.9]
DTR90D-010	10:1	58 [516]	53 [471]	48 [426]	140 [1237]	58 [510]	51 [452]	44 [394]	1,54 [13.7]	5,0 [44.5]
DTR90D-012	12:1	29 [253]	24 [215]	24 [209]	140 [1237]	28 [247]	22 [199]	22 [193]	1,31 [11.6]	7,1 [62.7]
DTR90D-015	15:1	38 [340]	35 [311]	32 [281]	140 [1237]	38 [336]	34 [298]	29 [260]	1,28 [11.3]	7,4 [65.8]
DTR90D-020	20:1	29 [261]	27 [238]	24 [215]	140 [1237]	29 [257]	26 [228]	22 [199]	1,22 [10.8]	7,1 [62.4]
DTR90D-025	25:1	22 [192]	20 [175]	18 [158]	140 [1237]	21 [189]	19 [168]	17 [146]	1,20 [10.6]	7,4 [65.6]
DTR90D-030	30:1	39 [348]	38 [333]	36 [318]	140 [1237]	39 [346]	37 [327]	35 [307]	1,25 [11.1]	6,1 [53.8]
DTR90D-040	40:1	30 [266]	29 [255]	28 [243]	140 [1237]	30 [265]	28 [250]	27 [235]	1,19 [10.6]	6,8 [60.5]
DTR90D-050	50:1	22 [196]	21 [188]	20 [179]	140 [1237]	22 [195]	21 [184]	20 [173]	1,17 [10.4]	7,3 [64.2]
DTR90D-060	60:1	60 [535]	60 [527]	59 [520]	140 [1237]	60 [534]	59 [524]	58 [514]	1,63 [14.4]	4,9 [43.5]
DTR90D-075	75:1	40 [352]	39 [346]	38 [340]	140 [1237]	40 [351]	39 [344]	38 [336]	1,31 [11.6]	6,4 [56.2]
DTR90D-090	90:1	40 [353]	39 [348]	39 [343]	140 [1237]	40 [352]	39 [346]	38 [339]	1,37 [12.1]	6,3 [55.8]
DTR90D-100	100:1	61 [536]	60 [532]	60 [527]	140 [1237]	61 [536]	60 [530]	59 [524]	1,55 [13.7]	5,0 [43.9]
DTR90D-120	120:1	31 [270]	30 [266]	30 [262]	140 [1237]	30 [269]	30 [265]	29 [260]	1,31 [11.6]	7,0 [62.0]
DTR90D-125	125:1	22 [198]	22 [195]	22 [192]	140 [1237]	22 [198]	22 [194]	21 [189]	1,23 [10.8]	7,4 [65.5]
DTR90D-150	150:1	40 [354]	40 [351]	39 [348]	140 [1237]	40 [353]	39 [350]	39 [346]	1,29 [11.4]	6,3 [56.1]
DTR90D-200	200:1	61 [538]	60 [535]	60 [533]	140 [1237]	61 [537]	60 [534]	60 [531]	1,52 [13.5]	4,6 [40.7]
DTR90D-250	250:1	23 [199]	22 [198]	22 [196]	140 [1237]	22 [199]	22 [197]	22 [195]	1,21 [10.7]	7,4 [65.4]
DTR90D-300	300:1	40 [355]	40 [353]	40 [352]	140 [1237]	40 [354]	40 [352]	40 [350]	1,26 [11.1]	6,1 [53.7]
DTR90D-400	400:1	31 [271]	31 [270]	30 [269]	140 [1237]	31 [271]	30 [270]	30 [268]	1,20 [10.6]	6,8 [60.5]
DTR90D-500	500:1	23 [200]	22 [199]	22 [198]	140 [1237]	23 [200]	22 [198]	22 [197]	1,18 [10.4]	7,3 [64.2]

Ratio 5P is designed using only PowerTRUE face gearing technology.
 Ratio 5T adds a True Planetary gearing stage for increased torque capacity.
¹ Ratios are exact, higher ratios are also available, consult factory.

T_r = Rated output torque at rated speed for specific hours of life.
 J = Mass moment of inertia reflected to the input shaft (including pinion assembly)
 T_{peak} = Allowable momentary peak torque for emergency stop or heavy shock loading.

DuraTRUE 90™ Size 115D (Dual Shaft)

Right Angle Gearheads

Metric

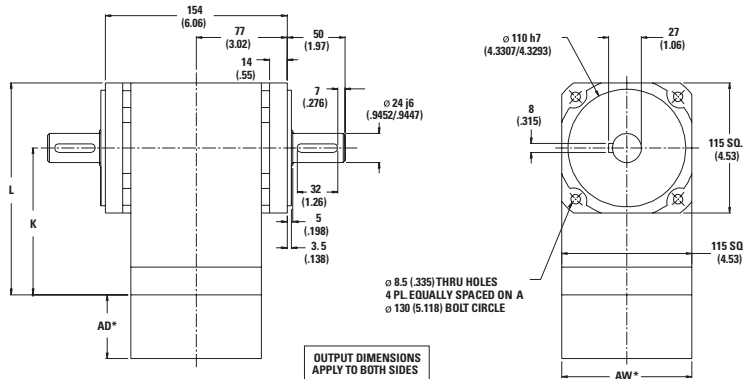

Ratio ¹	Dimension 'K' mm [in]	Dimension 'L' mm [in]	Backlash [arc-min]	Weight kg [lb]	Efficiency
1:1 to 5:1P	137 (5.41)	195 (7.76)	8 max	9 [20]	98%
5:1T to 50:1	169 (6.64)	226 (8.90)	9 max	11 [24]	93%
60:1 to 500:1	200 (7.87)	257 (10.13)	9 max	12 [27]	88%

All dimensions are: mm (inch)
 AW* = Adapter width
 AD* = Adapter length
 Both will vary depending on motor.
 Efficiency is calculated at 100% of the rated torque.

Performance Specifications

Part Number	Ratio ¹	10,000 Hour Life			T peak Nm [in-lb]	20,000 Hour Life			J kg-cm ² [in-lb-sec ² x10 ⁻⁴]	Torsional Stiffness Nm/arc-min [in-lb/arc-min]
		T _r (1000 rpm) Nm [in-lb]	T _r (3000 rpm) Nm [in-lb]	T _r (5000 rpm) Nm [in-lb]		T _r (1000 rpm) Nm [in-lb]	T _r (3000 rpm) Nm [in-lb]	T _r (5000 rpm) Nm [in-lb]		
DTR115D-001	1:1	63 [554]	57 [506]	52 [457]	283 [2505]	58 [512]	53 [467]	48 [422]	5,28 [46.7]	7,6 [67.6]
DTR115D-002	2:1	112 [989]	102 [903]	92 [816]	283 [2505]	103 [913]	94 [834]	85 [754]	2,71 [23.9]	12,5 [111]
DTR115D-003	3:1	87 [768]	79 [701]	72 [634]	283 [2505]	80 [709]	73 [647]	66 [585]	2,33 [20.6]	14,2 [126]
DTR115D-004	4:1	58 [511]	53 [467]	48 [422]	283 [2505]	53 [472]	49 [431]	44 [390]	2,16 [19.1]	14,9 [132]
DTR115D-005P	5:1P	43 [384]	40 [350]	36 [316]	283 [2505]	40 [354]	37 [323]	33 [292]	2,12 [18.8]	15,3 [135]
DTR115D-005T	5:1T	170 [1505]	126 [1117]	108 [958]	283 [2505]	143 [1262]	102 [907]	88 [778]	2,78 [24.6]	15,3 [135]
DTR115D-006	6:1	131 [1163]	112 [989]	109 [960]	283 [2505]	129 [1138]	103 [913]	100 [887]	2,77 [24.5]	10,2 [90.7]
DTR115D-009	9:1	102 [903]	87 [768]	84 [746]	283 [2505]	100 [884]	80 [709]	78 [689]	2,32 [20.5]	12,8 [113]
DTR115D-010	10:1	135 [1198]	124 [1094]	112 [989]	283 [2505]	134 [1183]	118 [1048]	103 [913]	2,63 [23.2]	10,2 [90.3]
DTR115D-012	12:1	68 [601]	58 [511]	56 [496]	283 [2505]	66 [588]	53 [472]	52 [458]	2,22 [19.6]	14,0 [124]
DTR115D-015	15:1	105 [930]	96 [849]	87 [768]	283 [2505]	104 [919]	92 [814]	80 [709]	2,18 [19.3]	14,6 [130]
DTR115D-020	20:1	70 [619]	64 [565]	58 [511]	283 [2505]	69 [612]	61 [542]	53 [472]	2,08 [18.4]	14,0 [124]
DTR115D-025	25:1	52 [465]	48 [424]	43 [384]	283 [2505]	52 [459]	46 [406]	40 [354]	2,04 [18.0]	14,6 [129]
DTR115D-030	30:1	107 [951]	103 [910]	98 [869]	283 [2505]	107 [945]	101 [892]	95 [840]	2,13 [18.9]	12,5 [111]
DTR115D-040	40:1	72 [633]	68 [606]	65 [579]	283 [2505]	71 [629]	67 [594]	63 [559]	2,03 [18.0]	13,8 [122]
DTR115D-050	50:1	54 [475]	51 [454]	49 [434]	283 [2505]	53 [472]	50 [446]	47 [419]	1,99 [17.6]	14,5 [128]
DTR115D-060	60:1	140 [1242]	138 [1224]	136 [1207]	283 [2505]	140 [1239]	137 [1217]	135 [1194]	2,78 [24.6]	10,0 [88.5]
DTR115D-075	75:1	109 [963]	107 [947]	105 [930]	283 [2505]	109 [960]	106 [939]	104 [919]	[2,22 19.7]	12,7 [112]
DTR115D-090	90:1	109 [964]	107 [951]	106 [937]	283 [2505]	109 [962]	107 [945]	105 [927]	2,33 [20.6]	12,6 [112]
DTR115D-100	100:1	141 [1245]	140 [1235]	138 [1224]	283 [2505]	141 [1244]	139 [1230]	137 [1217]	2,64 [23.3]	10,1 [89.5]
DTR115D-120	120:1	73 [642]	72 [633]	70 [624]	283 [2505]	72 [641]	71 [629]	70 [617]	2,23 [19.7]	13,9 [123]
DTR115D-125	125:1	54 [481]	53 [473]	52 [465]	283 [2505]	54 [480]	53 [469]	52 [459]	2,08 [18.4]	14,6 [129]
DTR115D-150	150:1	109 [967]	108 [959]	107 [951]	283 [2505]	109 [966]	108 [955]	107 [945]	2,19 [19.4]	12,7 [112]
DTR115D-200	200:1	141 [1248]	140 [1243]	140 [1237]	283 [2505]	141 [1247]	140 [1240]	139 [1234]	2,59 [22.9]	9,8 [87.1]
DTR115D-250	250:1	55 [483]	54 [479]	54 [475]	283 [2505]	54 [482]	54 [477]	53 [472]	2,05 [18.1]	14,6 [129]
DTR115D-300	300:1	109 [969]	109 [965]	109 [961]	283 [2505]	109 [968]	109 [963]	108 [958]	2,14 [18.9]	12,5 [111]
DTR115D-400	400:1	73 [645]	73 [642]	73 [640]	283 [2505]	73 [645]	72 [641]	72 [638]	2,04 [18.1]	13,8 [122]
DTR115D-500	500:1	55 [484]	54 [482]	54 [480]	283 [2505]	55 [483]	54 [481]	54 [478]	2,00 [17.7]	14,5 [128]

Ratio 5P is designed using only PowerTRUE face gearing technology.
 Ratio 5T adds a True Planetary gearing stage for increased torque capacity.
¹ Ratios are exact, higher ratios are also available, consult factory.

T_r = Rated output torque at rated speed for specific hours of life.
 J = Mass moment of inertia reflected to the input shaft (including pinion assembly)
 T_{peak} = Allowable momentary peak torque for emergency stop or heavy shock loading.

DuraTRUE 90™ Size 142D (Dual Shaft)

Right Angle Gearheads

Metric

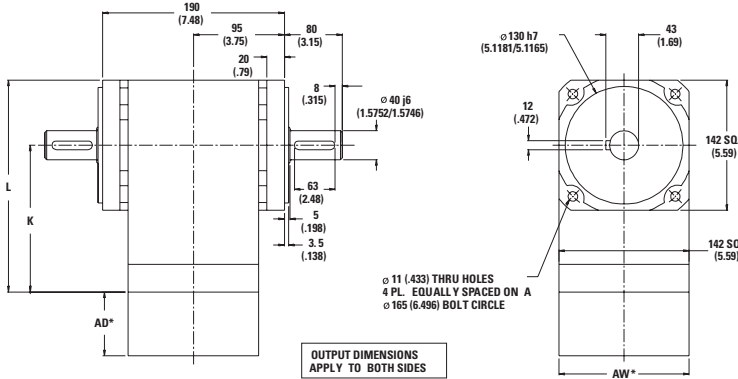

Ratio ¹	Dimension 'K' mm [in.]	Dimension 'L' mm [in.]	Backlash [arc-min]	Weight kg [lb]	Efficiency
1:1 to 5:1P	163 [6.43]	234 [9.22]	8 max	19 [43]	98%
5:1T to 50:1	233 [9.17]	304 [11.96]	9 max	24 [53]	93%
60:1 to 500:1	262 [10.3]	332 [13.10]	9 max	28 [62]	88%

All dimensions are: mm (inch)
 AW* = Adapter width
 AD* = Adapter length
 Both will vary depending on motor.
 Efficiency is calculated at 100% of the rated torque.

Performance Specifications

Part Number	Ratio ¹	10,000 Hour Life			T _{peak} Nm [in.-lb]	20,000 Hour Life			J [in.-lb-sec ² ×10 ⁻⁴]	Torsional Stiffness Nm/arc-min [in.-lb/arc-min]
		T _r (1000 rpm) Nm [in.-lb]	T _r (3000 rpm) Nm [in.-lb]	T _r (5000 rpm) Nm [in.-lb]		T _r (1000 rpm) Nm [in.-lb]	T _r (3000 rpm) Nm [in.-lb]	T _r (5000 rpm) Nm [in.-lb]		
DTR142D-001	1:1	135 [1194]	123 [1090]	111 [985]	865 [7659]	125 [1103]	114 [1006]	103 [910]	26,3 [232]	23,7 [210]
DTR142D-002	2:1	279 [2474]	255 [2257]	231 [2041]	865 [7659]	258 [2284]	236 [2084]	213 [1885]	13,5 [119]	38,9 [344]
DTR142D-003	3:1	188 [1663]	171 [1518]	155 [1372]	865 [7659]	174 [1536]	158 [1401]	143 [1267]	11,6 [102]	44,1 [390]
DTR142D-004	4:1	135 [1194]	123 [1090]	111 [985]	865 [7659]	125 [1103]	114 [1006]	103 [910]	10,8 [95.1]	46,3 [410]
DTR142D-005P	5:1P	101 [896]	92 [818]	84 [739]	865 [7659]	93 [827]	85 [755]	77 [683]	10,6 [93.3]	47,4 [419]
DTR142D-005T	5:1T	340 [3009]	289 [2559]	281 [2484]	865 [7659]	333 [2944]	267 [2363]	259 [2294]	13,8 [122]	47,4 [419]
DTR142D-006	6:1	329 [2909]	279 [2474]	271 [2402]	865 [7659]	322 [2846]	258 [2284]	251 [2218]	13,8 [122]	31,8 [281]
DTR142D-009	9:1	221 [1956]	188 [1663]	182 [1614]	865 [7659]	216 [1913]	174 [1536]	168 [1491]	11,6 [102]	39,6 [351]
DTR142D-010	10:1	339 [2996]	309 [2735]	279 [2474]	865 [7659]	334 [2958]	296 [2621]	258 [2284]	13,1 [116]	31,6 [280]
DTR142D-012	12:1	159 [1404]	135 [1194]	131 [1159]	865 [7659]	155 [1374]	125 [1103]	121 [1071]	11,1 [97.7]	43,4 [384]
DTR142D-015	15:1	228 [2014]	208 [1839]	188 [1663]	865 [7659]	225 [1989]	199 [1762]	174 [1536]	10,9 [95.9]	45,4 [402]
DTR142D-020	20:1	163 [1446]	149 [1320]	135 [1194]	865 [7659]	161 [1428]	143 [1265]	125 [1103]	10,4 [91.5]	43,3 [383]
DTR142D-025	25:1	123 [1085]	112 [991]	101 [896]	865 [7659]	121 [1071]	107 [949]	93 [827]	10,2 [89.8]	45,3 [401]
DTR142D-030	30:1	233 [2058]	223 [1970]	213 [1882]	865 [7659]	231 [2045]	218 [1932]	205 [1819]	10,6 [93.8]	38,8 [343]
DTR142D-040	40:1	167 [1478]	160 [1415]	153 [1352]	865 [7659]	166 [1469]	157 [1387]	148 [1306]	10,1 [89.4]	42,8 [379]
DTR142D-050	50:1	125 [1109]	120 [1061]	115 [1014]	865 [7659]	125 [1102]	118 [1041]	111 [980]	9,91 [87.6]	45,0 [398]
DTR142D-060	60:1	351 [3105]	346 [3061]	341 [3018]	865 [7659]	350 [3099]	344 [3042]	337 [2986]	13,8 [122]	31,0 [274]
DTR142D-075	75:1	236 [2084]	232 [2049]	228 [2014]	865 [7659]	235 [2079]	230 [2034]	225 [1989]	11,1 [97.9]	39,4 [348]
DTR142D-090	90:1	236 [2087]	233 [2058]	229 [2029]	865 [7659]	235 [2083]	231 [2045]	227 [2008]	11,6 [103]	39,1 [346]
DTR142D-100	100:1	352 [3114]	349 [3088]	346 [3061]	865 [7659]	351 [3110]	348 [3076]	344 [3042]	13,1 [116]	31,3 [278]
DTR142D-120	120:1	169 [1499]	167 [1478]	165 [1457]	865 [7659]	169 [1496]	166 [1469]	163 [1442]	11,1 [98.2]	43,0 [380]
DTR142D-125	125:1	127 [1123]	125 [1104]	123 [1085]	865 [7659]	127 [1120]	124 [1096]	121 [1071]	10,4 [91.7]	45,3 [401]
DTR142D-150	150:1	237 [2093]	235 [2076]	233 [2058]	865 [7659]	236 [2091]	234 [2068]	231 [2045]	10,9 [96.4]	39,3 [348]
DTR142D-200	200:1	353 [3120]	351 [3107]	350 [3094]	865 [7659]	352 [3118]	350 [3101]	349 [3085]	12,9 [114]	30,5 [270]
DTR142D-250	250:1	127 [1128]	126 [1118]	125 [1109]	865 [7659]	127 [1126]	126 [1114]	125 [1102]	10,2 [90.3]	45,2 [400]
DTR142D-300	300:1	237 [2098]	236 [2089]	235 [2080]	865 [7659]	237 [2096]	236 [2085]	234 [2074]	10,7 [94.3]	38,8 [343]
DTR142D-400	400:1	170 [1506]	169 [1500]	169 [1494]	865 [7659]	170 [1505]	169 [1497]	168 [1489]	10,2 [89.8]	42,8 [379]
DTR142D-500	500:1	128 [1130]	127 [1125]	127 [1121]	865 [7659]	128 [1129]	127 [1123]	126 [1117]	9,96 [88.1]	45,0 [398]

Ratio 5P is designed using only PowerTRUE face gearing technology.
 Ratio 5T adds a True Planetary gearing stage for increased torque capacity.
¹ Ratios are exact, higher ratios are also available, consult factory.

T_r = Rated output torque at rated speed for specific hours of life.
 J = Mass moment of inertia reflected to the input shaft (including pinion assembly)
 T_{peak} = Allowable momentary peak torque for emergency stop or heavy shock loading.

DuraTRUE 90™
Hollow & Dual

Radial and Axial Load Ratings

DTR60D

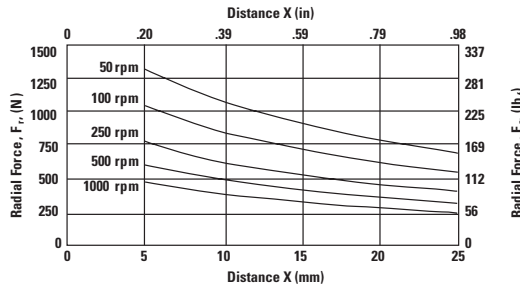
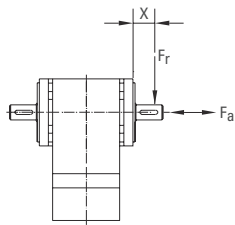

Speed rpm	Axial Load, F_a N [lb _f]
50	2155 [484]
100	1710 [384]
250	1260 [283]
500	1000 [225]
1000	794 [178]

DTR90D

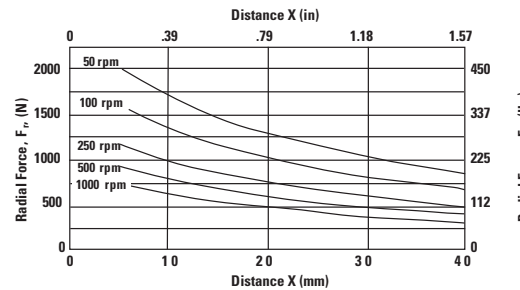
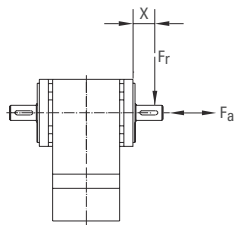

Speed rpm	Axial Load, F_a N [lb _f]
50	3157 [710]
100	2506 [563]
250	1846 [415]
500	1465 [329]
1000	1163 [261]

DTR115D

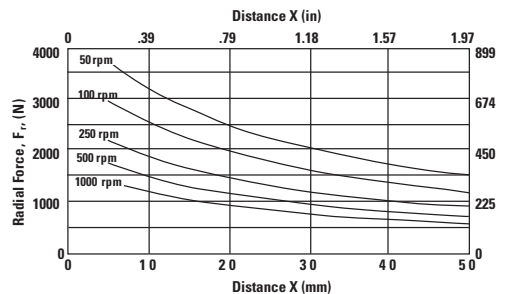
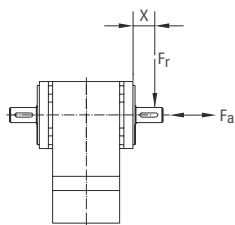

Speed rpm	Axial Load, F_a N [lb _f]
50	5742 [1291]
100	4558 [1025]
250	3358 [755]
500	2665 [599]
1000	2115 [476]

DTR142D

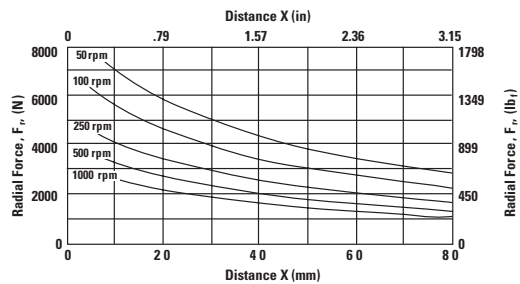
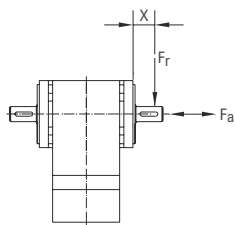

Speed rpm	Axial Load, F_a N [lb _f]
50	11925 [2681]
100	9465 [2128]
250	6974 [1568]
500	5535 [1244]
1000	4393 [988]

These graphs display the allowable radial load at a given distance (X) from the mounting surface based on an L_{10} life of 10,000 hours for the mean output speed n_{mout} , as described on page 10.