

# WH80

## Belt Drive, Wheel Guide

- » Ordering key - see page 214
- » Accessories - see page 137
- » Additional data - see page 193

### General Specifications

Parameter	WH80
Profile size (w × h) [mm]	80 × 80
Type of belt	32ATL10
Carriage sealing system	none
Adjustable belt tensioning	the belt can be retensioned by the customer if necessary
Lubrication	lubrication og guiding surfaces
Included accessories	4 × mounting clamps

### Performance Specifications

Parameter		WH80
Stroke length (S max), maximum	[mm]	11000
Linear speed, maximum	[m/s]	10,0
Acceleration, maximum	[m/s <sup>2</sup> ]	40
Repeatability	[± mm]	0,05
Input speed, maximum	[rpm]	3000
Operation temperature limits	[°C]	0 – 80
Dynamic load (Fx), maximum	[N]	2700 <sup>3</sup>
Dynamic load (Fy), maximum	[N]	882 <sup>1</sup> / 8150 <sup>2</sup>
Dynamic load (Fz), maximum	[N]	2100 <sup>1</sup> / 14680 <sup>2</sup>
Dynamic load torque (Mx), maximum	[Nm]	75 <sup>1</sup> / 480 <sup>2</sup>
Dynamic load torque (My), maximum	[Nm]	230 <sup>1</sup> / 1610 <sup>2</sup>
Dynamic load torque (Mz), maximum	[Nm]	100 <sup>1</sup> / 900 <sup>2</sup>
Drive shaft force (Frd), maximum	[N]	500
Drive shaft torque (Mta), maximum	[Nm]	100
Pulley diameter	[mm]	63,66
Stroke per shaft revolution	[mm]	200
Weight of unit with zero stroke of every 100 mm of stroke of each carriage	[kg]	8,63 0,93 2,75

<sup>1</sup> Value for the complete unit

<sup>2</sup> Value for the wheel guide only

<sup>3</sup> See diagram Force Fx

### Carriage Idle Torque, (M idle) [Nm]

Input speed [rpm]	Idle torque [Nm]
150	2,4
1500	3,5
3000	5,0

M idle = the input torque needed to move the carriage with no load on it.

### Deflection of the Profile

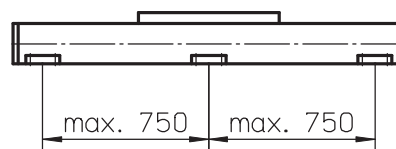

A mounting clamp must be installed at least at every 750 mm to be able to operate the maximum load. Less clamps may be required if less load is being operated, see the additional technical data for more information. Units with a profile length over 6300 mm consists of two profiles where the joint between the two profiles must be adequately supported on both sides.

### Force Fx as a Function of the Speed

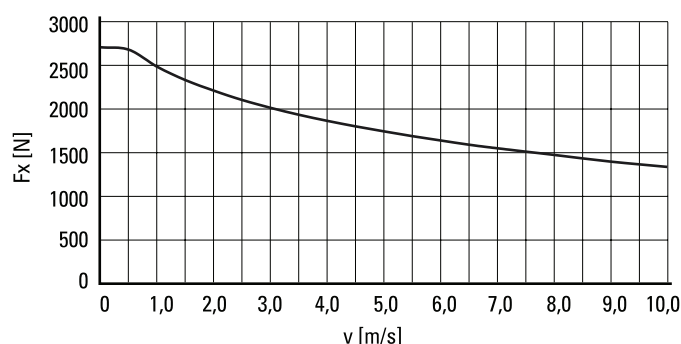

### Definition of Forces

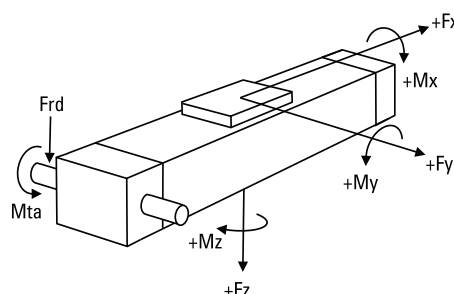

# WH80

## Belt Drive, Wheel Guide

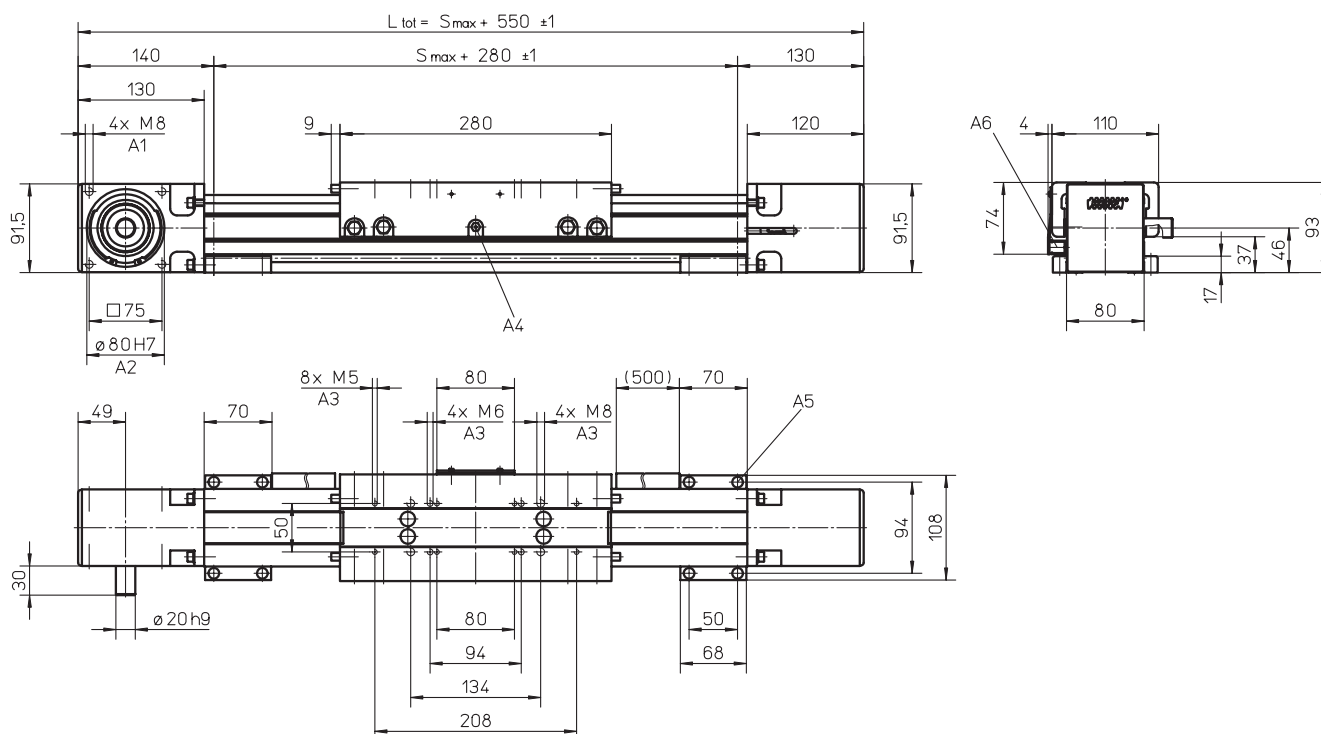

A1: depth 16  
 A2: depth 2,5  
 A3: depth 12

A4: funnel type lubricating nipple DIN3405-M6x1-D1  
 A5: socket cap screw ISO4762-M6x20 8.8  
 A6: ENF inductive sensor rail option kit (optional)

### Long Carriage

Parameter	WH80	
Carriage length	[mm]	450
Dynamic load torque (My), maximum	[Nm]	345
Dynamic load torque (Mz), maximum	[Nm]	150
Weight	[kg]	3,43

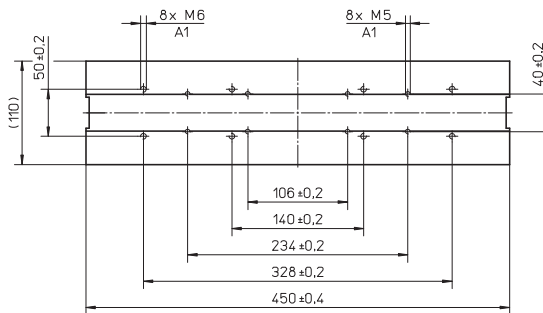

A1: depth 12

### Double Carriages

Parameter	WH80	
Minimum distance between carriages (L <sub>A</sub> )	[mm]	300
Dynamic load (F <sub>y</sub> ), maximum	[N]	1764
Dynamic load (F <sub>z</sub> ), maximum	[N]	4200
Dynamic load torque (M <sub>y</sub> ), maximum	[Nm]	L <sub>A</sub> <sup>1</sup> × 0,882
Dynamic load torque (M <sub>z</sub> ), maximum	[Nm]	L <sub>A</sub> <sup>1</sup> × 2,1
Force required to move second carriage	[N]	20
Total length (L <sub>tot</sub> )	[mm]	S <sub>max</sub> + 550 + L <sub>A</sub>

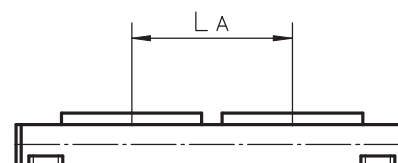

<sup>1</sup> Value in mm