

WM80Z

Belt Drive, Ball Guide, Short Carriage

- » Ordering key - see page 210
- » Accessories - see page 137
- » Additional data - see page 192

General Specifications

Parameter	WM80Z
Profile size (w × h) [mm]	80 × 80
Type of belt	25 AT 10
Carriage sealing system	self-adjusting plastic cover band
Adjustable belt tensioning	the belt can be retensioned by the customer if necessary
Lubrication	central lubrication of all parts that require lubrication
Included accessories	4 × mounting clamps

Performance Specifications

Parameter		WM80Z
Stroke length (S max), maximum	[mm]	5500
Linear speed, maximum	[m/s]	5,0
Acceleration, maximum	[m/s ²]	20
Repeatability	[± mm]	0,05
Input speed, maximum	[rpm]	885
Operation temperature limits	[°C]	0 – 80
Dynamic load (F _x), maximum	[N]	1470
Dynamic load (F _y), maximum	[N]	2100 ¹ / 37450 ²
Dynamic load (F _z), maximum	[N]	2100 ¹ / 35840 ²
Dynamic load torque (M _x), maximum	[Nm]	68 ¹ / 890 ²
Dynamic load torque (M _y), maximum	[Nm]	135 ¹ / 580 ²
Dynamic load torque (M _z), maximum	[Nm]	135 ¹ / 610 ²
Drive shaft force (F _{rd}), maximum	[N]	600
Drive shaft torque (M _{ta}), maximum	[Nm]	40
Pulley diameter	[mm]	54,11
Stroke per shaft revolution	[mm]	170
Weight	[kg]	
of unit with zero stroke		9,2
of every 100 mm of stroke		0,8
of each carriage		2,1

¹ Value for the complete unit, also see diagram Force F_x

² Value for the ball guide only

Carriage Idle Torque, (M_{idle}) [Nm]

Input speed [rpm]	Idle torque [Nm]
150	4,0
450	5,4
885	6,2

M_{idle} = the input torque needed to move the carriage with no load on it.

Deflection of the Profile

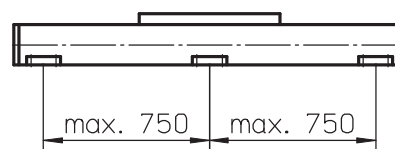

A mounting clamp must be installed at least at every 750 mm to be able to operate the maximum load. Less clamps may be required if less load is being operated, see the additional technical data for more information.

Force F_x as a Function of the Speed

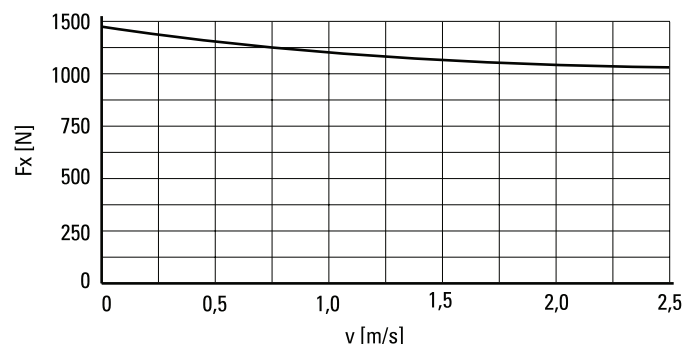

Definition of Forces

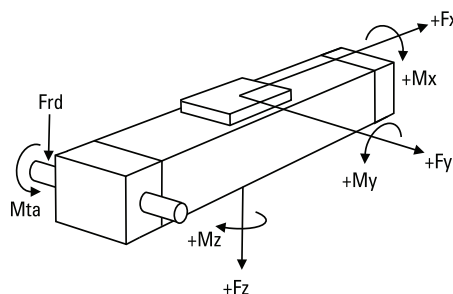

WM80Z

Belt Drive, Ball Guide, Short Carriage

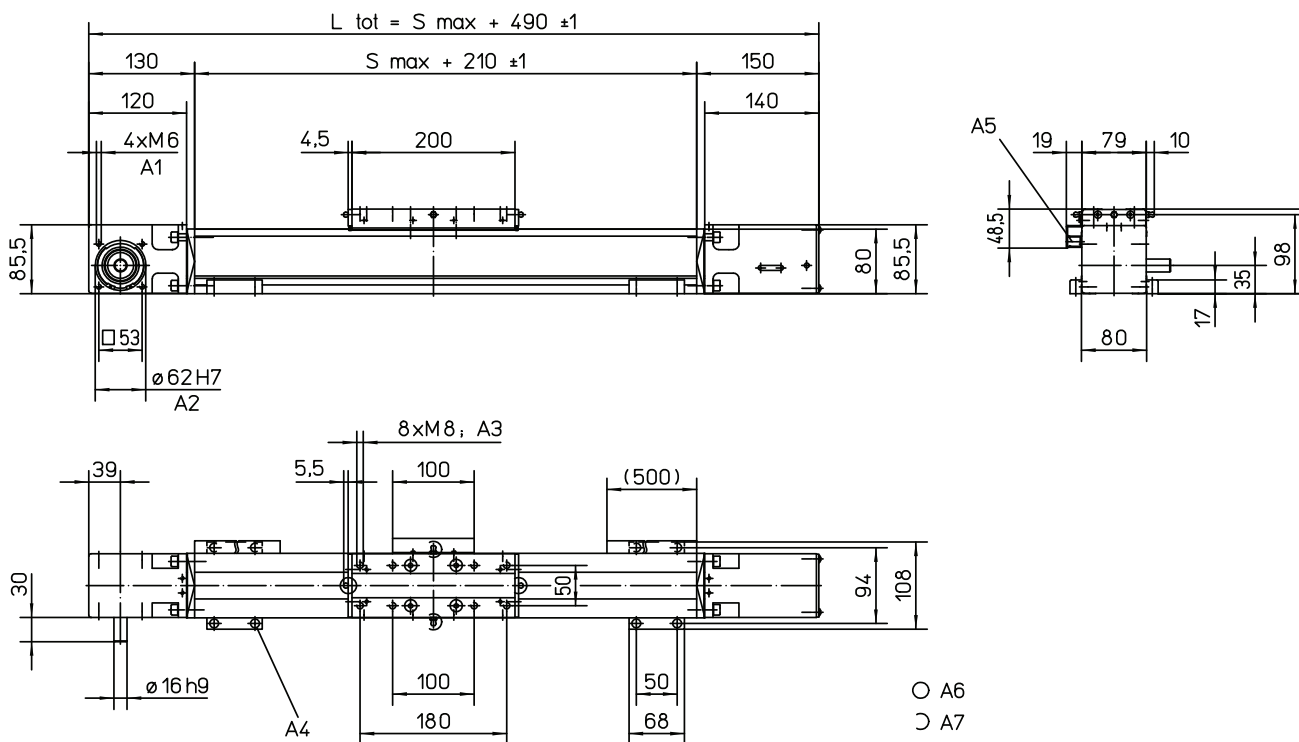

A1: depth 15
 A2: depth 2,5
 A3: depth 12
 A4: socket cap screw ISO4762-M6x20 8.8

A5: ENF inductive sensor rail option kit (optional)
 A6: tapered lubricating nipple to DIN71412 AM6 on fixed-bearing side as standard feature
 A7: can be changed over to one of three alternative lubrications points by the customer

Double Short Carriages

Parameter		WM80Z
Minimum distance between carriages (L _A)	[mm]	280
Dynamic load (F _y), maximum	[N]	4200
Dynamic load (F _z), maximum	[N]	4200
Dynamic load torque (M _y), maximum	[Nm]	L A ¹ × 2,1
Dynamic load torque (M _z), maximum	[Nm]	L A ¹ × 2,1
Force required to move second carriage	[N]	225
Total length (L _{tot})	[mm]	S _{max} + 490 + L A

¹ Value in mm

