

# WB40

## Ball Screw or Lead Screw Drive, Slide Guide

- » Ordering key - see page 206
- » Accessories - see page 137
- » Additional data - see page 192

### General Specifications

Parameter	WB40
Profile size (w × h) [mm]	40 × 37
Type of screw	ball or lead screw with single nut
Carriage sealing system	plastic cover band
Screw supports	none
Lubrication	central lubrication of all parts that require lubrication
Included accessories	4 × mounting clamps

### Carriage Idle Torque ( $M_{idle}$ ) [Nm]

Input speed [rpm]	Screw lead [mm]		
	p = 4	p = 5	p = 8
150	-	0,02	-
1500	-	0,35	-
3000	-	0,50	-

$M_{idle}$  = the input torque needed to move the carriage with no load on it.

### Deflection of the Profile

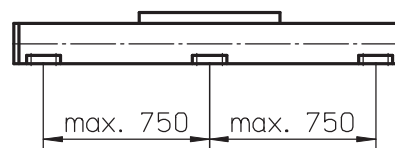

A mounting clamp must be installed at least at every 750 mm to be able to operate the maximum load. Less clamps may be required if less load is being operated, see the additional technical data for more information.

### Performance Specifications

Parameter		WB40
Stroke length (S max), maximum	[mm]	1000
Linear speed, maximum	[m/s]	0,25
Acceleration, maximum	[m/s <sup>2</sup> ]	5
Repeatability	[± mm]	0,05
Input speed, maximum	[rpm]	
Ball screw units		3000
Lead screw units with composite nut		1500
Operation temperature limits	[°C]	0 – 80
Dynamic load ( $F_x$ ), maximum	[N]	
ball screw units / lead screw units		200 / 500
Dynamic load ( $F_y$ ), maximum	[N]	200 <sup>1</sup>
Dynamic load ( $F_z$ ), maximum	[N]	250 <sup>1</sup>
Dynamic load torque ( $M_x$ ), maximum	[Nm]	6 <sup>1</sup>
Dynamic load torque ( $M_y$ ), maximum	[Nm]	15 <sup>1</sup>
Dynamic load torque ( $M_z$ ), maximum	[Nm]	10 <sup>1</sup>
Drive shaft force ( $F_{rd}$ ), maximum	[N]	80
Drive shaft torque ( $M_{ta}$ ), maximum	[Nm]	1
Screw diameter ( $d_0$ )	[mm]	12
Screw lead (p)	[mm]	
ball screw units / lead screw units		5 / 4, 8
Weight	[kg]	
of unit with zero stroke		1,07
of every 100 mm of stroke		0,30
of each carriage		0,45

<sup>1</sup> Value for the complete unit

### Critical Speed

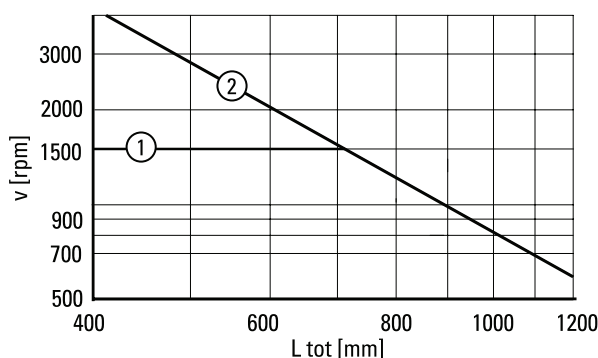

- 1: For lead screw units
- 2: For ball screw units

### Definition of Forces

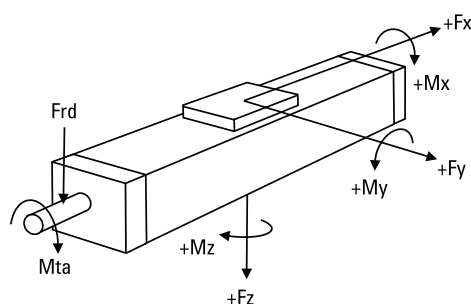

# WB40

## Ball Screw or Lead Screw Drive, Slide Guide

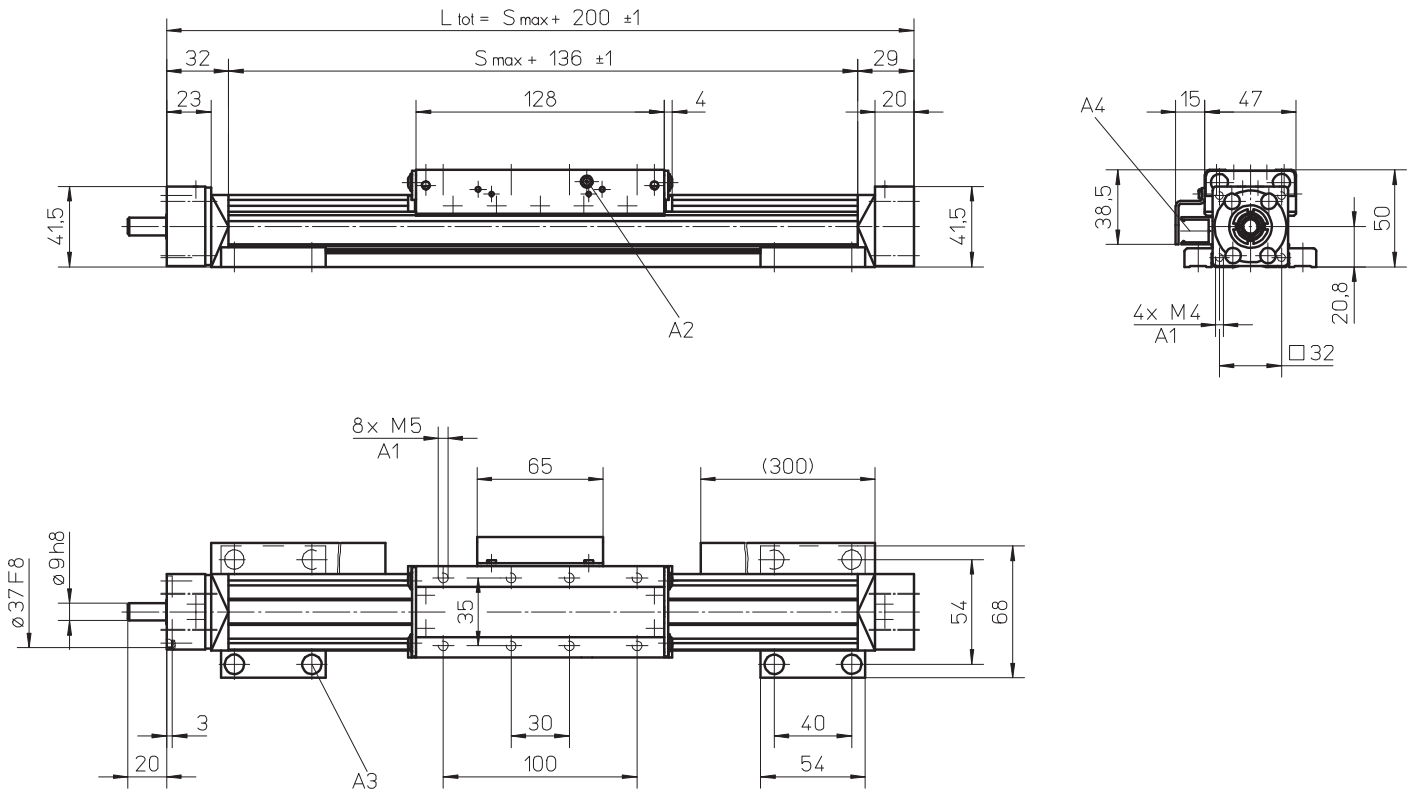

A1: depth 10  
 A2: lubricating nipple DIN3405 D 1/A

A3: socket cap screw ISO4762-M5x20 8.8  
 A4: ENF inductive sensor rail option kit (optional)