

# Quantum Series Brushless DC Motors

For Further Information Contact ....

Heason Technologies Group Ltd

Tel: +44(0)1403 755800

Fax: +44(0)1403 755810

Email: sales@heason.com

Freephone 0800 374903 www.heason.com

**Heason**  
Technologies Group

## Holding Brake Options

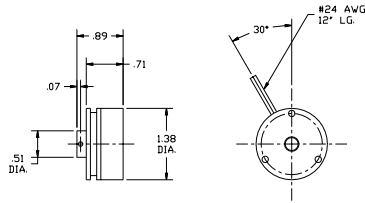

FIG. 1

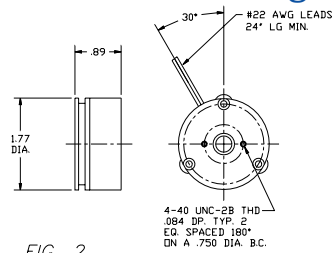

FIG. 2

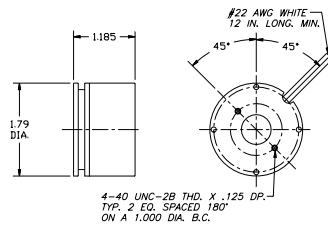

FIG. 3

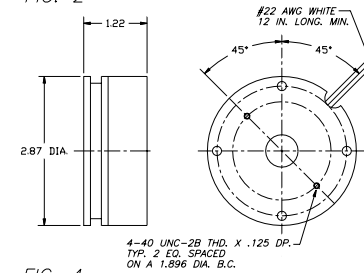
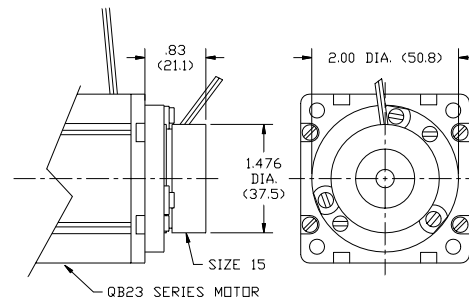
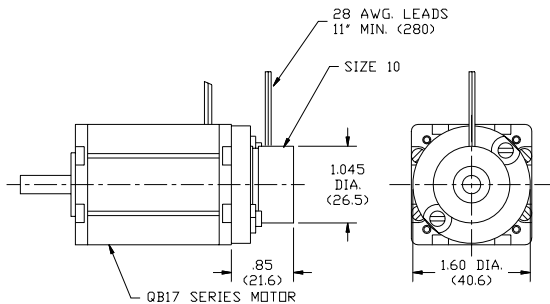

FIG. 4

BRAKE PART NO.	9760196 FIG. 1	9760183 FIG. 2	9760184 FIG. 3	9760185 FIG. 4
STATIC TORQUE: LB.IN(Nm) <i>M<sub>tr</sub></i>	1 (0.11)	5 (0.56)	10(1.12)	40(4.51)
COIL: VOLTAGE (DC)	24	24	24	24
RESISTANCE (OHMS) ±10%	138	82.3	52.5	36
WATTS (MAX)	-	7.0	11	16
PULL IN VOLTAGE (MAX. DC)	18	18	16	16

1. ENCODERS CAN BE MOUNTED TO EACH BRAKE EXCEPT 9760196. SEPARATE ENCODER MOUNTING PLATE REQUIRED ON BRAKES 9760184, 185

## Resolver Options



RESOLVER SIZE 10 AND 15	
INPUT VOLTAGE	AC 7V <sub>rms</sub> 10 KHZ
INPUT CURRENT	60 mA MAX.
TEMP. RANGE	-55° TO 155°C
MAX. OPERATING SPEED	10000 RPM

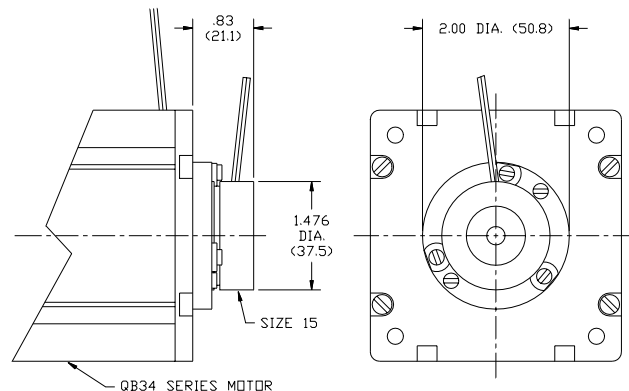
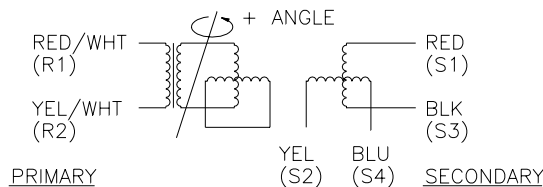

**Hathaway**  
**Emoteq, Inc**

Emoteq, Inc  
10002 E. 43rd St. So.  
Tulsa, OK 74116  
USA  
Tel 918 627 1845  
Fax 918 660 0207  
20

Emoteq UK  
Box 772,  
Rottingdean BN2 8ND  
United Kingdom  
Tel 01273 390800  
Fax 01273 301060