

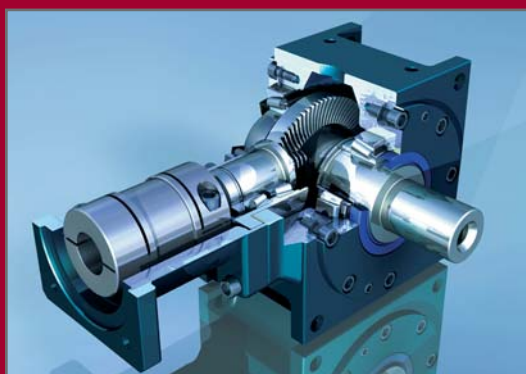

ZF Maschinenantriebe GmbH
Industrial Drives



ZF-SERVOPLAN[®]

*Right angle gearboxes
for servomotors*

For Further Information Contact

Heason Technologies Group Ltd

Tel: +44(0)1403 755800

Fax: +44(0)1403 755810

Email: sales@heason.com

Freephone 0800 374903 www.heason.com

Heason
Technologies Group

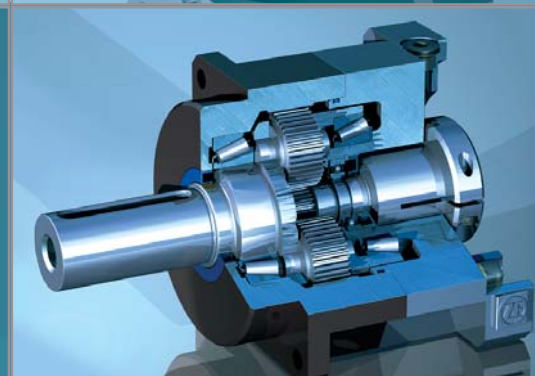
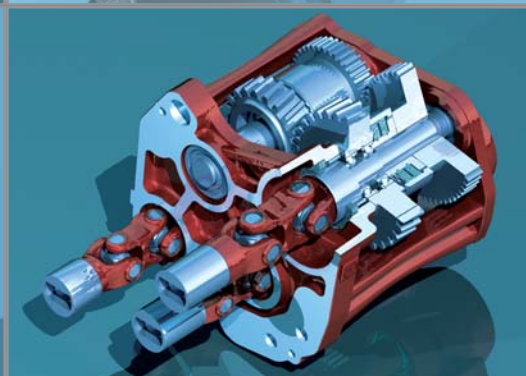
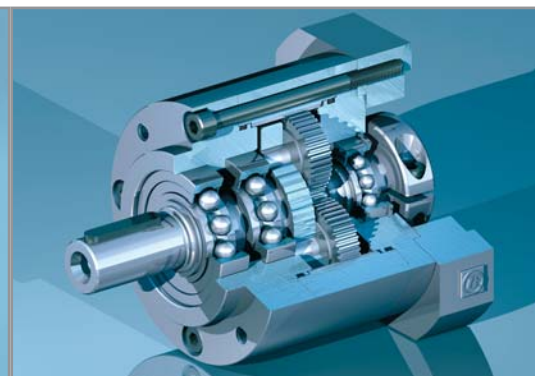
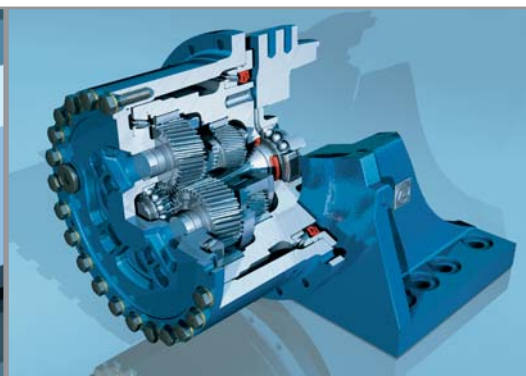
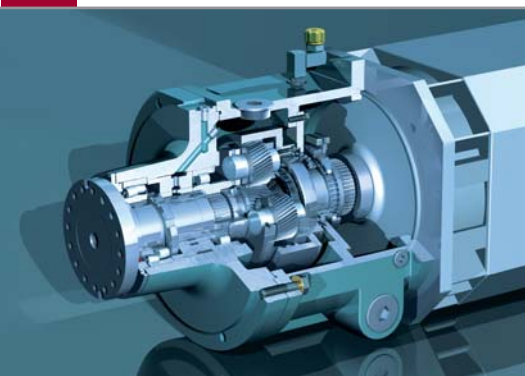

ZF-Duoplan 2K
Two-speed Gearboxes

ZF-Ecolift
Elevator Gearboxes

ZF-Servoplan PGE
Servogearboxes Economy

ZF-Tiratron
Hysteresis Brakes

Customer specific
Gearboxes

ZF-Servoplan PG
Servogearboxes

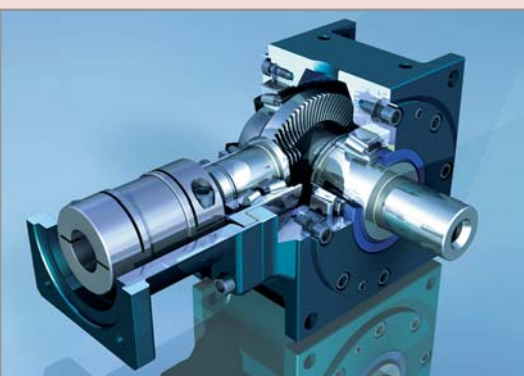

Z F - S e r v o p l a n W T
R i g h t A n g l e g e a r b o x e s

Precision in movement

The ZF Maschinenantriebe GmbH is able to offer you a wide range of machine drives, brakes and clutches for applications in engineering as well as customer specific drive solutions.

Our development and production activities are focused on servo-assisted drives for automation engineering, two-speed drive gearboxes for machine tools as well as customer-specific drives, such as for printing machines, robot applications and elevator gearboxes.

Our innovative standard products range from low backlash servogearboxes (ZF-Servoplan), and robust two-speed gearboxes (ZF-Duoplan) to hysteresis clutches and brakes for non-contact web control (ZF-Tiratron).



Right angle gearboxes

The ZF Servoplan bevel gear system of the WT range has been designed for highly dynamic servodrives. The newly developed hypoid gearing allows for high transmission ratios. A reduced torsional backlash and a high position accuracy are achieved through optimized manufacturing techniques. These features make these transmission ranges most suitable for applications in automation engineering.

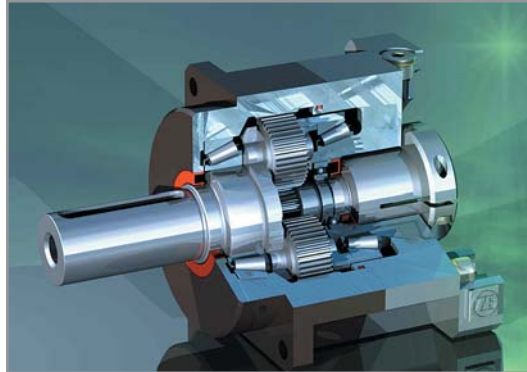

Apart from right angle gears for servodrives, ZF Maschinenantriebe GmbH also offers planetary gearboxes with a low backlash suitable for automation engineering.

1. Newly designed Gleason hypoid gearing for the most exact regulating accuracy which allows the high transmission ratios of a bevel gear
2. Reduced backlash as a result of optimized manufacturing techniques
3. Maintenance-free thanks to life-time lubrication
4. The high-quality tapered roller bearings ensure a good tilt resistance and ideal bearing loads
5. Backlash-free torque transmission as a result of a frictional connection between shaft and hub
6. One-piece low-weight cast aluminum casing for highest stiffness
7. Optimized contact pattern of the hypoid gearing for even tooth loads
8. Highest possible efficiency of up to 96 %

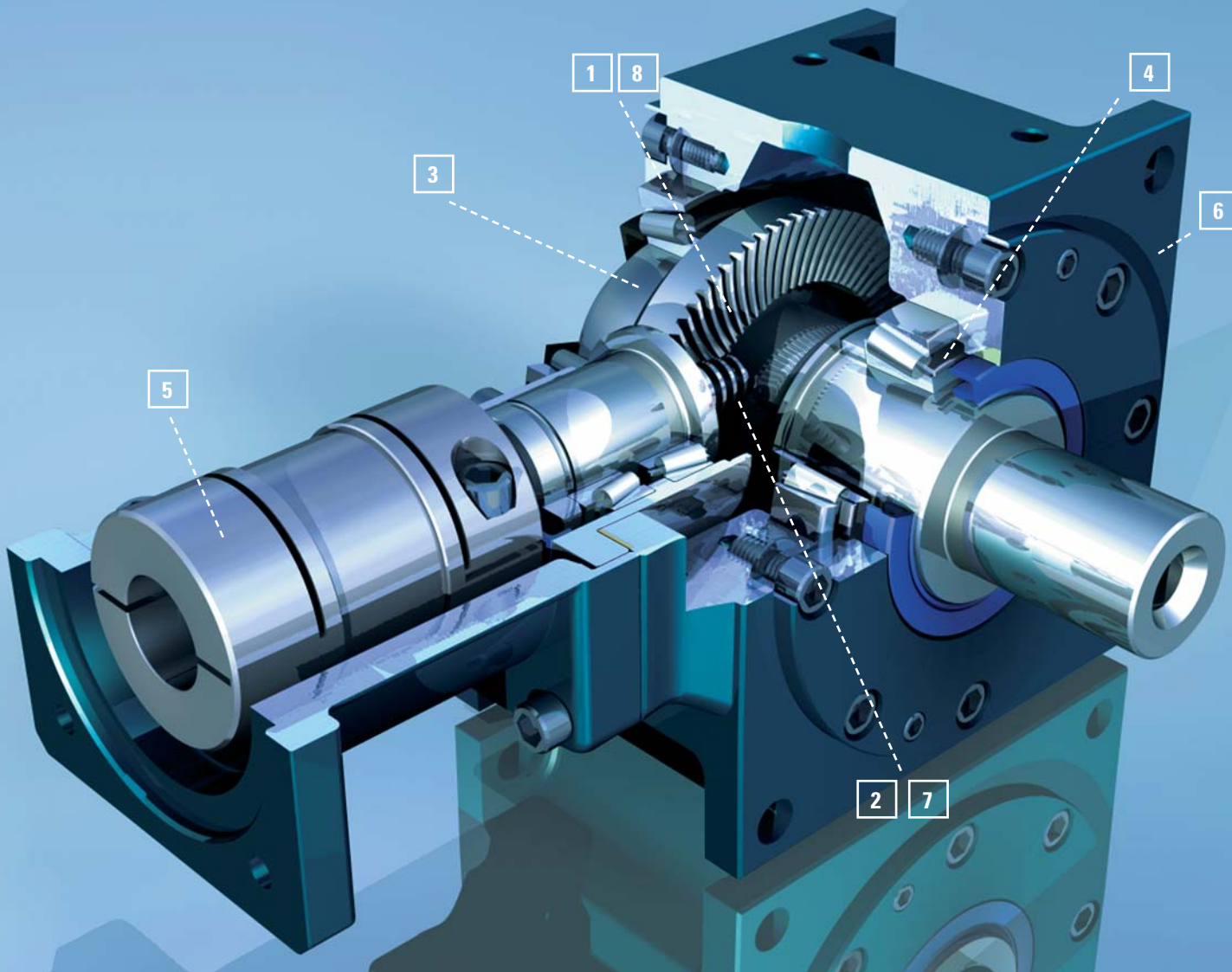

Right angle gearboxes

Size :

Technical data :

		i		WT 35	WT 70	WT 140	WT 260	WT 700	WT 1400
Nominal output torque	T_{2N} (Nm)	3-10	35	70	140	260	720	1 440	
		12-15	25	50	95	180	510	1 020	
Emergency stop torque ¹⁾	T_{2Not} (Nm)	3-10	70	140	280	520	1 440	2 880	
		12-15	50	100	190	360	1 020	2 040	
Max. acceleration torque	T_{2B} (Nm)	3-10	53	105	210	390	1 080	2 160	
		12-15	38	75	143	270	765	1 530	
Max. input speed	n_{1max} (rpm)		8 000	8 000	7 000	6 000	5 000	4 500	
Nominal input speed	n_{1n} (rpm)		6 000	6 000	5 000	4 000	3 000	2 500	
Backlash	φ (arcmin)	Stand. redu. ⁻¹	≤ 5	≤ 5	≤ 4	≤ 4	≤ 4	≤ 4	
			≤ 3	≤ 3	≤ 2	≤ 2	≤ 2	≤ 2	
Torsional rigidity	C_1 (Nm/arcmin)		3.5	7	17.5	39	103	210	
Moments of inertia	I_1 (kg cm ²)	3	0.43	1.10	2.5	6.7	24	72	
		4	0.31	0.77	1.8	4.7	16	48	
		5	0.24	0.63	1.4	3.8	13	37	
		6	0.22	0.56	1.3	3.4	11	28	
		8	0.18	0.47	1.1	2.8	8.6	24	
		10	0.16	0.43	1.0	2.5	7.5	20	
		12	0.15	0.41	0.93	2.4	6.9	18	
15	0.14	0.39	0.89	2.3	6.3	16			
Max. axial force	F_A (N)		1 650	2 450	3 600	5 000	7 500	11 250	
Max. radial force ²⁾	F_R (N)		3 300	4 900	7 200	10 000	15 000	22 500	
Idling torque ($n_1 = 3000$ rpm)	T_{01} (Nm)	3	0.044	0.079	0.114	0.190	0.390	0.729	
		10	0.024	0.043	0.065	0.101	0.189	0.311	
Lifetime ³⁾	L_h (h)		> 30 000	> 30 000	> 30 000	> 30 000	> 30 000	> 30 000	
Efficiency	η	3-10	≥ 96%	≥ 96%	≥ 96%	≥ 96%	≥ 96%	≥ 96%	
		12/15	≥ 93%	≥ 93%	≥ 93%	≥ 93%	≥ 93%	≥ 93%	
Weight	m (kg)		2.5	5	8.5	15	28	48	
Operating noise at $n_{an} = 3000$ rpm	L_p (db(A))		≤ 66	≤ 66	≤ 68	≤ 68	≤ 70	≤ 72	
Lubrication	Lifetime lubrication, closed system								
Surface protection	Prime coat RAL 9005 - dull black								
Installation position	any								
Operating temperature	- 10 °C to 100 °C								
Direction of rotation input to output	same as motor								
Type of protection	IP 64								

1) Max.1000 times in gearboxes lifetime.

2) At a maximum of 1000 cycles per hour, with the correction factor to be taken into consideration in any other case.

3) Collective load as a basis for the design.

4) Resultant force: center of output shaft at output speed 400 rpm.

Dimensions (mm) :

	WT 35	WT 70	WT 140	WT 260	WT 700	WT 1400
A	60	80	100	120	146	196
B	90	115	140	170	215	260
∅ b (g6)	89	105	125	150	195	245
g	13.5	8.5	8	8	10	10
o	9	14	18	23	32	42
p ₁	39	49	59	72	91	112
p ₂	22	27	33	40	52	70
∅ k ₁	6.6	9	11	14	17.5	17.5
k ₂	M6	M8	M10	M12	M16	M16
q	8	10	11	13	15	17
∅ d ₂ (k6)	20	24	32	40	55	70
l ₂	35	40	50	60	90	110
f ₂	80	90	110	130	175	220
n	1.5	1.5	2	2	2	2
∅ d _w (H7)	20	25	30	40	55	70
∅ d _s (f7)	24	30	36	50	68	80
h ₀	20	22	26	29	32	34
h ₁	23	25	29	33	37	40
f _s	71.5	79.5	93	107	127	159
∅ d ₁	9/11/14	11/14/19	14/19/24	19/24/32	24/32/38	32/38/48
l ₁	23/26/30	26/30/40	30/40/50	40/50/60	50/60/80	60/80/80
u x f ₁	55 x 130	75 x 168	90 x 191	115 x 220	140 x 260	190 x 335
	-	90 x 168	115 x 191	140 x 220	190 x 265	260 x 345
	75 x 140	90 x 180	115 x 201	140 x 235	190 x 280	-
r	According to DIN 332 Form D,					
∅ v	PCD, spigot dia thread and centering depth					
∅ w	according to respective motor data sheets.					
s						
m						

Installation dimensions

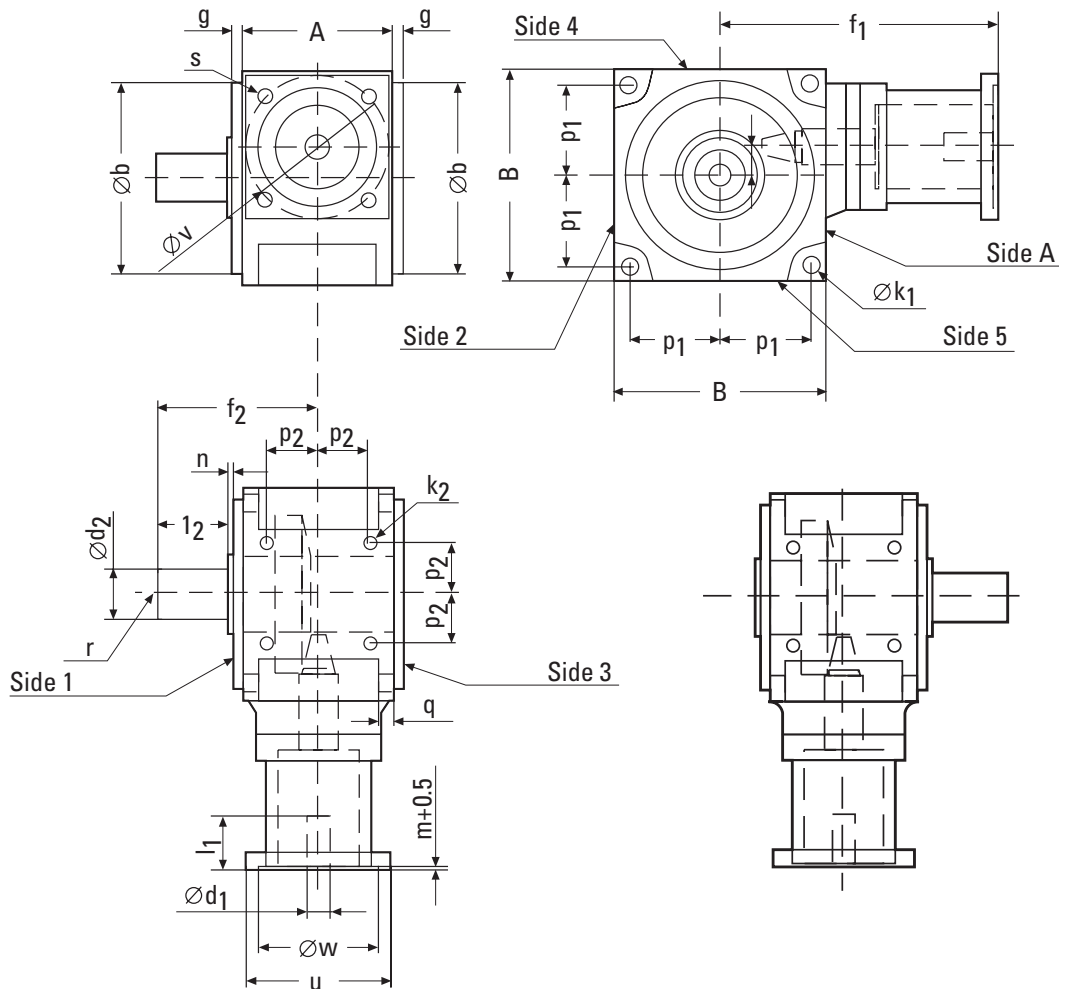

Design 1L

Design 3L

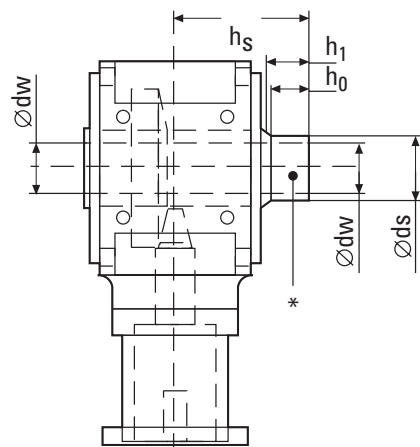

Design 1LSV

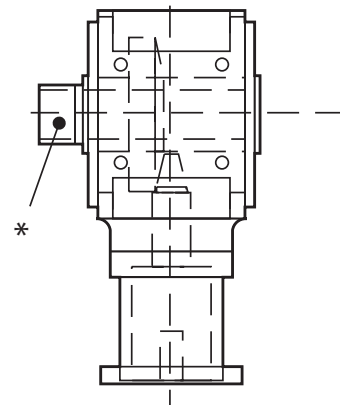

Design 3LSV

*Hollow shaft. Optional fixing via shrink ring

Shape of output shaft

Bevel gear systems with following output shaft types:

Type 1L

Solid shaft, no keyway;
Lefthand output, seen from input.

Type 3L

Solid shaft, no keyway;
Righthand output, seen from input.

All solid shaft types have a face-end centering bore with D DIN 332 thread.

Type 1LSV

Hollow shaft. Optional fixing via shrink ring.

Lefthand output, seen from input.

Type 3LSV

Hollow shaft. Optional fixing via shrink ring. Righthand output, seen from input.

Installation position

The right angle gearboxes are of B5 design for flange mounting.

Installation position as required.

As per DIN EN 60 034-7 (06.96 issue), the installation positions illustrated can be used.

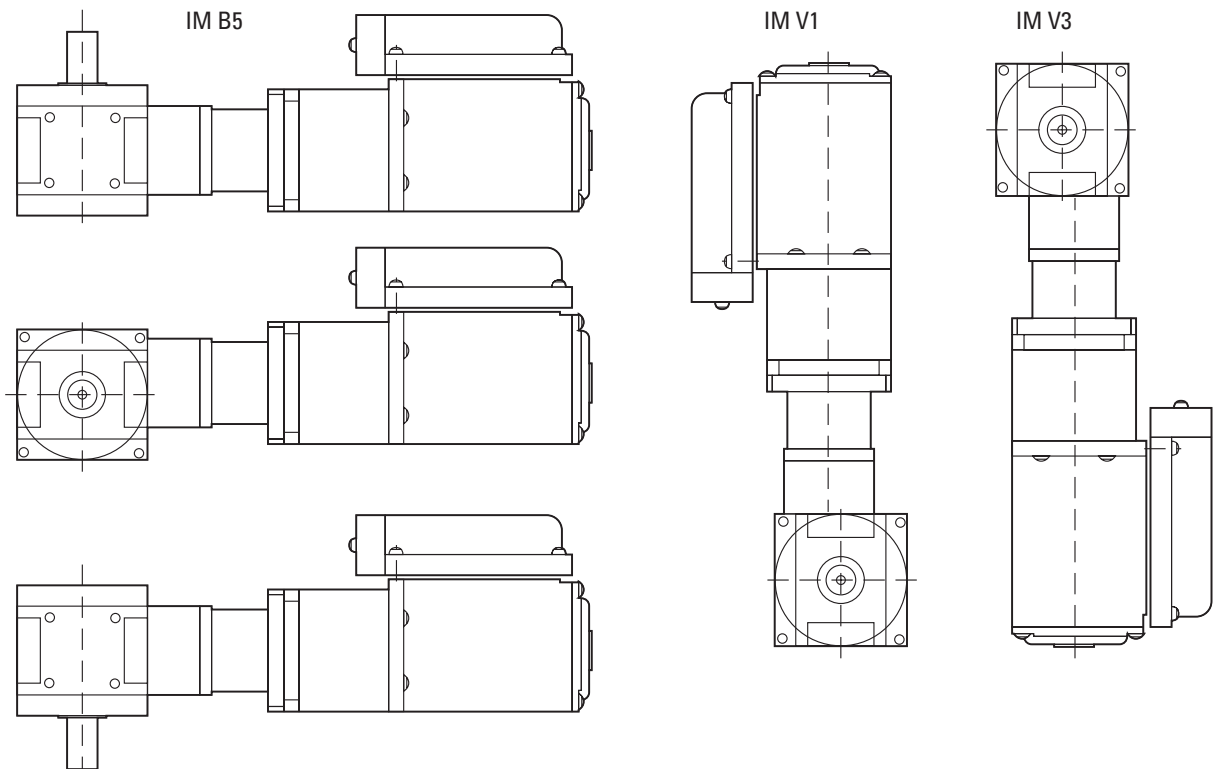

Configuration and selection

Type of protection

Right angle gearboxes are protected against penetration of diverse external media. The type of protection is designated as IEC 35-5 for electric machinery and specified by the letters IP (international protection) and two code numbers.

For mechanical right angle gears the designation is IP64.

The first digit designates the degree of protection against contact (screen protection) and penetration of foreign bodies.

In this instance, the digit 6 means

- protection against dust infiltration (dust-tight)
- complete screen protection.

The second digit designates the degree of protection against water.

In this instance, the digit 4 means

- water sprayed against the machine from all directions (jet water) must not cause any damage to the machine.

Operating modes S4 and S5

The right angle gearboxes are designed for operating mode S4 (intermittent periodic duty with starting) and operating mode S5 (intermittent periodic duty with braking), both as per EN 60034-1.

In this instance, the cyclic duration factor (c.d.f) should not exceed 60%. For S4 mode (intermittent periodic duty), the following applies:

$$\text{c.d.f.} = \frac{t_A + t_B}{t_S} \times 100\%$$

For S5 mode (intermittent periodic duty with braking), the following applies:

$$\text{c.d.f.} = \frac{t_A + t_B + t_{Br}}{t_S} \times 100\%$$

One process sequence t_S comprises one each of rise time, load period, braking time (if needed) and idle time. This is defined as a cycle.

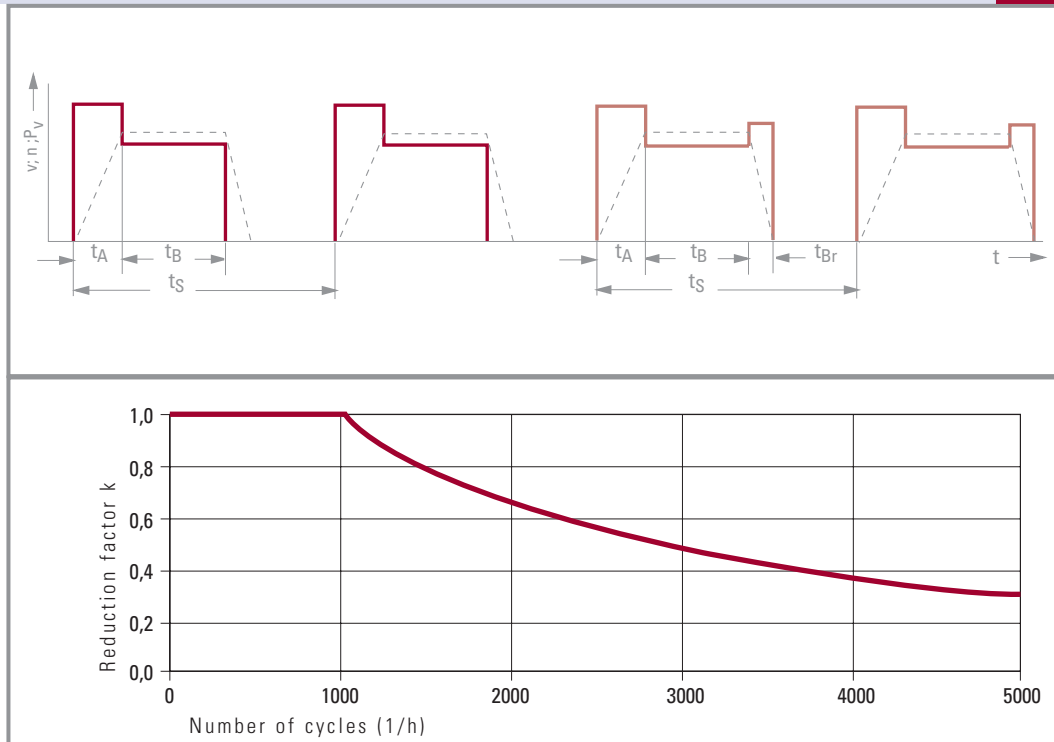

The number of cycles should not exceed 1000 per hour.

If more than 1000 cycles per hour are required, this is possible with reduced input torque $T_{2B \text{ perm.}}$ (Reduction factor k)

- n: speed -----
- v: velocity (speed) -----
- P_v : power loss -----
- t: time
- t_A : rise time
- t_B : load time
- t_{Br} : braking time
- t_S : cycle duration

Gearbox selection

The following is intended as an aid for simple and fast selection of a gearbox for your use in consideration of the mode of operation. C.d.f. = cyclic duration factor. S.o.t. = switch-on time. Indices: Capital letters = physical gearbox limit values (nominal value). Small letters = actually applied values (actual value).

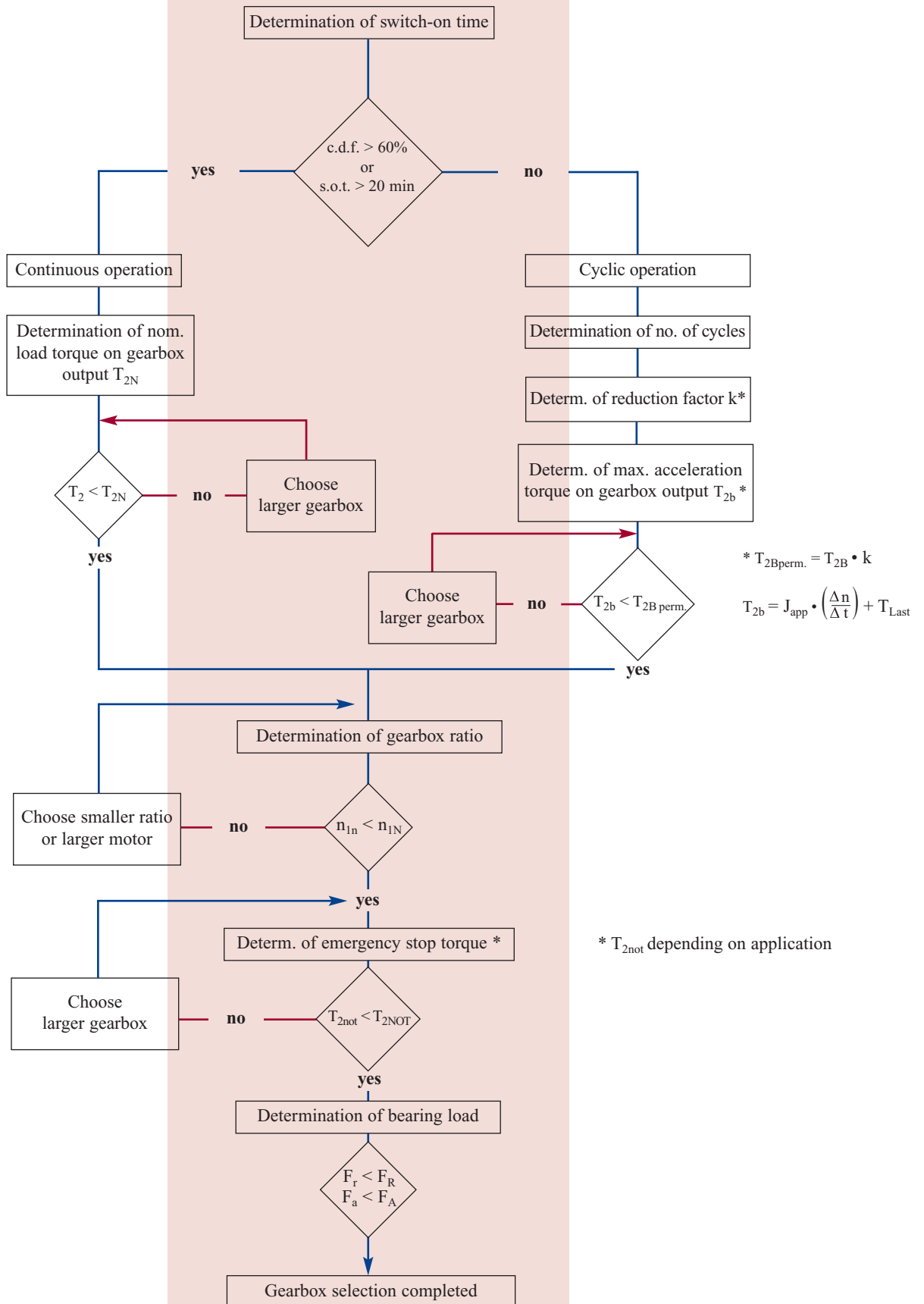

Quotation?

For fastest processing of your request we need following facts from you simply by:

Fax: ++49/(0)7541/77-3470 or

E-Mail: industrial-drives@zf.com



Motor make:

Type:

Connection dimensions:

Shaft diameter (mm):

Centering diameter (mm):

Fixing hole circle diameter (mm):

Thread size (pitch): M

Power (kw):

Gearbox size: WT

Gearbox ratio (i):

Design:

Basis of quotation (volume):

Planned annual demand:



Subject to technical change without notice. For installation investigation purposes, please request installation drawings; only the data contained therein is binding.

Please check out our homepage: [http:// industrial-drives.zf.com](http://industrial-drives.zf.com)

ZF Maschinenantriebe GmbH
Ehlersstrasse 50
88046 Friedrichshafen/Germany
Telefon: +49(0)7541-77-0
Telefax: +49(0)7541-77-3470
e-Mail: industrial-drives@zf.com
Internet: <http://industrial-drives.zf.com>

