

RT-8™ Ball Bearing Rotary Table

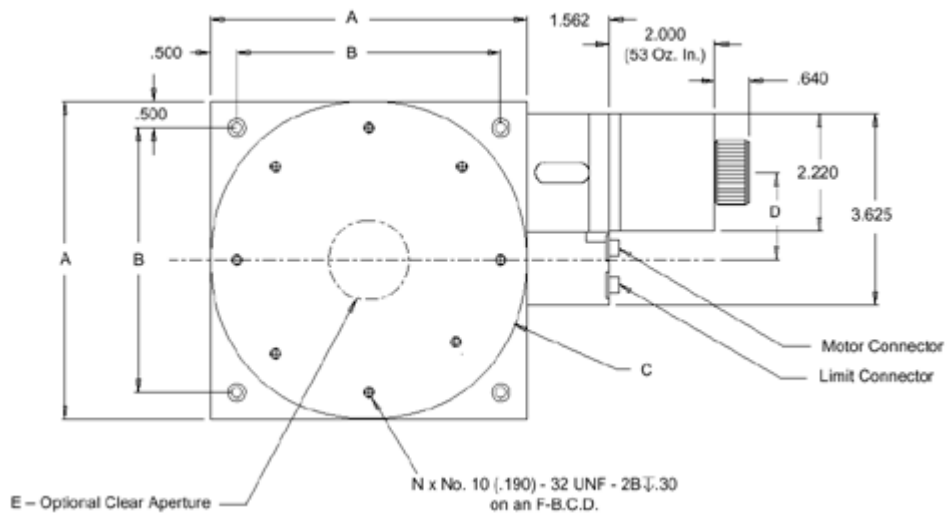

Product Dimensions

Dimensions - Top View



Dimensions - Side View

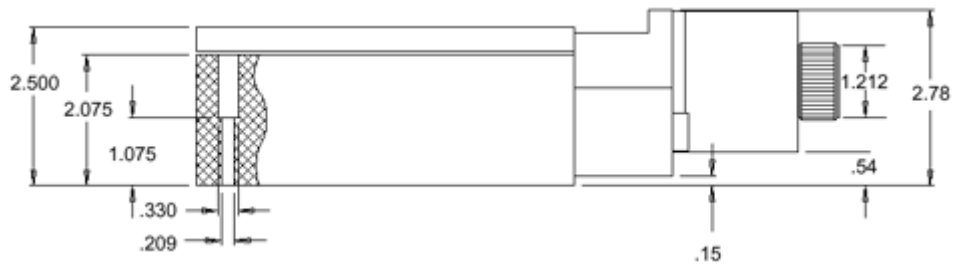

A	B	C	D	E	F	N
8	7	8.00	1.66	1.5	6.000	8

RT-8™ Ball Bearing Rotary Table

Specifications

Diameter (inches)	8	
Worm/Gear Ratio	180:1	36:1
Resolution ¹	0.001	0.005
Accuracy	0.05	
Bidirectional Repeatability (degree)	0.007	
Vertical Runout (µm)	<25	
Radial Runout (µm)	20	
Axis Runout (degree)	0.03	
Load Capacity (kg)	20	
Radial Load Capacity (kg)	7	
Maximum Speed	15 rps at worm	
Total Mass (kg)	6.4	

Configurations²

Motor	Stepper (oz-in)	400 step/rev 200 step/rev	118, Others 53, 100, Others
	Servo		brush, brushless

Options

Encoder	Rotary (counts/rev.)	2000, 4000
---------	----------------------	------------

¹ Resolution assuming ±10 microstep drive and standard 200 step/rev. stepping motor, or servo motor with 2000 count/rev. rotary encoder.

² Standard configuration is highlighted.

For Further Information Contact

Heason Technologies Group Ltd
 Tel: +44(0)1403 755800
 Fax: +44(0)1403 755810
 Email: sales@heason.com

Heason
Technologies Group

Freephone 0800 374903 www.heason.com