

## RT-12™ Ball Bearing Rotary Table

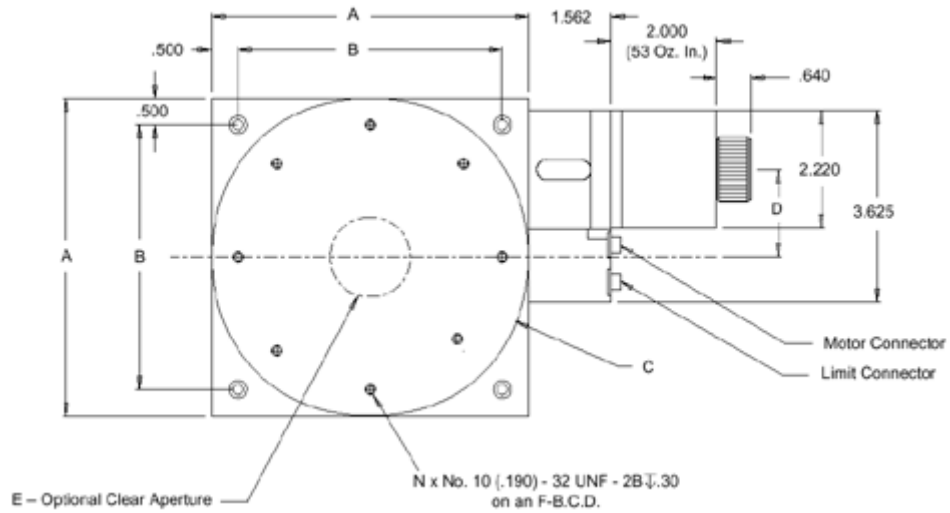

### Product Dimensions

#### Dimensions - Top View



#### Dimensions - Side View

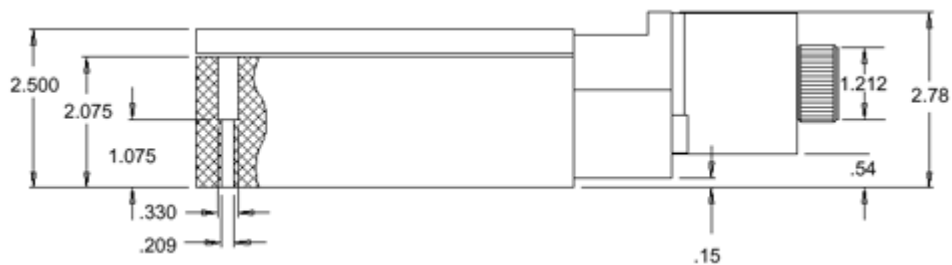

A	B	C	D	E	F	N
10	9	10.00	3.03	3.0	8.000	8

## RT-12™ Ball Bearing Rotary Table

### Specifications

Diameter (inches)	10
Worm/Gear Ratio	180:1
Resolution <sup>1</sup>	0.001
Accuracy	0.05
Bidirectional Repeatability (degree)	0.005
Vertical Runout (µm)	<25
Radial Runout (µm)	20
Axis Runout (degree)	0.03
Load Capacity (kg)	30
Radial Load Capacity (kg)	12
Maximum Speed	15 rps at worm
Total Mass (kg)	9.1

### Configurations<sup>2</sup>

Motor	Stepper (oz-in)	400 step/rev 200 step/rev	118, Others 53, 100, Others
	Servo		brush, brushless

### Options

Encoder	Rotary (counts/rev.)	2000, 4000
---------	----------------------	------------

<sup>1</sup> Resolution assuming ÷10 microstep drive and standard 200 step/rev stepping motor or servo motor with 2000 count/rev rotary encoder.

<sup>2</sup> Standard configuration is highlighted.

**For Further Information Contact ....**

Heason Technologies Group Ltd  
 Tel: +44(0)1403 755800  
 Fax: +44(0)1403 755810  
 Email: sales@heason.com

**Heason**  
Technologies Group

**Freephone 0800 374903 www.heason.com**