

Systems
Technical
Publication

Kollmorgen RBE Motors with Kollmorgen SERVOSTAR™ S Series Amplifier



The Kollmorgen RBE brushless, frameless motor series provides optimum system performance in direct drive applications where the motor is integrated into a machine. The RBE series uses rare-earth magnets to achieve very high continuous and peak ratings. A wide range of frame sizes is available which allow for large diameter holes through the rotors. When combined with the Kollmorgen SERVOSTAR digital amplifier, the system becomes an easy to set up, high performance motion control system.

For Further Information Contact

Heason Technologies Group Ltd

Tel: +44(0)1403 755800

Fax: +44(0)1403 755810

Email: sales@heason.com

Freephone 0800 374903 www.heason.com

Heason
Technologies Group

KOLLMORGEN



Kollmorgen SERVOSTAR™ Amplifier

- **115 or 230 Volt AC Input Power (to PA Power Supply)**
- **Resolver or Encoder Feedback Standard with Kollmorgen GOLDLINE Motors**
- **Fully Digital Control**

The SERVOSTAR amplifier is a compact, fully digital amplifier designed to simplify installation and system set-up. Three control algorithms and self-tuning (to the load) functionality allows high performance operation to be achieved quickly and easily.

Since not one control algorithm is best for all machines, SERVOSTAR contains Pole Placement, PI, and PDFF control algorithms. SERVOSTAR utilizes the PC-based MOTIONLINK® for Windows which automatically takes you through the key steps of installation and start up.

FEATURES:

Servo Control

- Advanced sinewave commutation technology provides smooth, precise low-speed control and high-speed performance
- Accurate torque control due to precision balanced current loops with closed loop sensors
- Velocity loop bandwidths to 400 Hz
- Self-tuning to the load
- Patented torque angle control that enhances motor performance
- Fully digital control loops
- Compact and attractive rugged metal package for space-saving, modern appearance - metal package minimizes electrical noise

- Pole Placement, PI, and PDFF control options
- Command modes: Torque (analog or serial); Velocity (analog or serial); Position (pulse following/electronic gearing)
- Six current ratings: 3, 6, 10, 20, 30 and 55 amps RMS/phase continuous
- Run time counter

Easy Connectivity

- Built in encoder equivalent output which can eliminate the need for an additional position feedback device
- RS232 or RS485 Communication
- Unique multi-drop configuration allows a PC or PLC to communicate to multiple SERVOSTAR amplifiers via single RS-232 connection
- SERVOSTAR's versatile communication capabilities make it easy to integrate machine control data directly from the factory floor to your information system
- Analog $\pm 10V$, pulse/direction, master encoder, serial port command options

Robust Design

- Excellent protection against miswired connection on 24 volt I/O
- ESD rugged circuit design and fully metallic enclosure
- Self-protecting intelligent power modules
- Full protection against short circuit, overvoltage, undervoltage, heatsink overtemperature, motor overtemperature, overspeed, overcurrent, and feedback loss
- UL and ULC listed, CE approval
- Flash memory

Windows Start-up Environment – MOTIONLINK®

- Advanced motion “wizard” automatically walks you through set-up
- PC “Oscilloscope” for measuring real-time motion performance

PA Series Power Supply

- PTC resistive soft-start technology eliminates nuisance tripping of fuses or breakers
- Six power supply options for optimal configuration of single and multi-axis systems
- Up to four amplifier axis can be used with one PA power supply, up to six with PA-LM logic only power supply
- Separate inputs for logic and bus voltages allow communications to SERVOSTAR without the bus power applied (PA14, PA28, PA50, PA75 and PA85 models)

INTRODUCTION



Kollmorgen RBE motors

- 1.49 oz-in to 28.9 lb-ft (0.0105 to 39.2 N-m)
- 0.840 to 9.42 Inches (21.3 to 239 mm)
- OD Round Frame
- Rotary Direct-Drive Frameless
- Built-In Hall Effect Feedback

The RBE Series brushless motors feature high energy product rare earth magnets resulting in high-continuous and peak torque ratings. These frameless RBE direct drive rotary packages provide great flexibility of design to the machine builder.

FEATURES:

- The RBE direct drive solution eliminates mechanical transmissions, such as gearboxes, belts, and pulleys. This results in a zero backlash, very quiet, zero maintenance servo solution.
- Direct drive allows improved servo stiffness and better response
- Rugged design withstands wide temperature fluctuations and vibration
- Mounting motor directly into the load or drive shaft saves space and eliminates motor protrusion
- High position accuracy resulting from no backlash in the transmission
- High temperature design
- Low cogging design

- Large torque to volume ratio
- Long life by virtue of brushless design
- Facilitates “sleek machines” by mounting motor directly to the drive shaft

OPTIONS:

- Housed models (RBEH) with stainless steel shafts. Standard options for housed models include fail-safe brakes, and resolver or encoder feedback.
- Special options for direct drive or housed models include:
 - high efficiency laminations for enhanced high speed operation
 - special windings
 - skewed stators for reduced torque ripple
 - mechanical variations

AUTO SET-UP

MOTIONLINK® for Windows takes the fear out of setting up a servo system. Designed for the novice as well as the advanced user, **MOTIONLINK** lets users quickly set-up and fine tune system performance.



The **SERVOSTAR** Auto Set-up consists of five steps to completely configure the **SERVOSTAR** and motor for your machine:

- 1** Set **SERVOSTAR** for the Power Source. **MOTIONLINK** will tell you if your **SERVOSTAR** was factory programmed for a line voltage. Push okay, if correct, if not, change to the appropriate voltage.
- 2** Set **SERVOSTAR** up for the Motor. If the amplifier has been programmed to operate a specific motor, **MOTIONLINK** will indicate the motor type. Push okay and go to the next step. If not, you can select from a listing of standard Kollmorgen motors or enter in the specific parameters from the motors you will be using.
- 3** Select the Operational Mode. Set **SERVOSTAR** to run in velocity or current mode. Set the command to be serial or analog.
- 4** Tune **SERVOSTAR** for the Load. Simply select the bandwidth you want the system to operate and press the Auto-tune button .
- 5** Store **SERVOSTAR** Settings : The final step is storing the parameters in **SERVOSTAR** and on your hard drive or disk.

Now you're ready to run your machine!

ADDITIONAL FUNCTIONS

MOTIONLINK® also includes other features that allow you to fine tune or monitor the performance of the system.

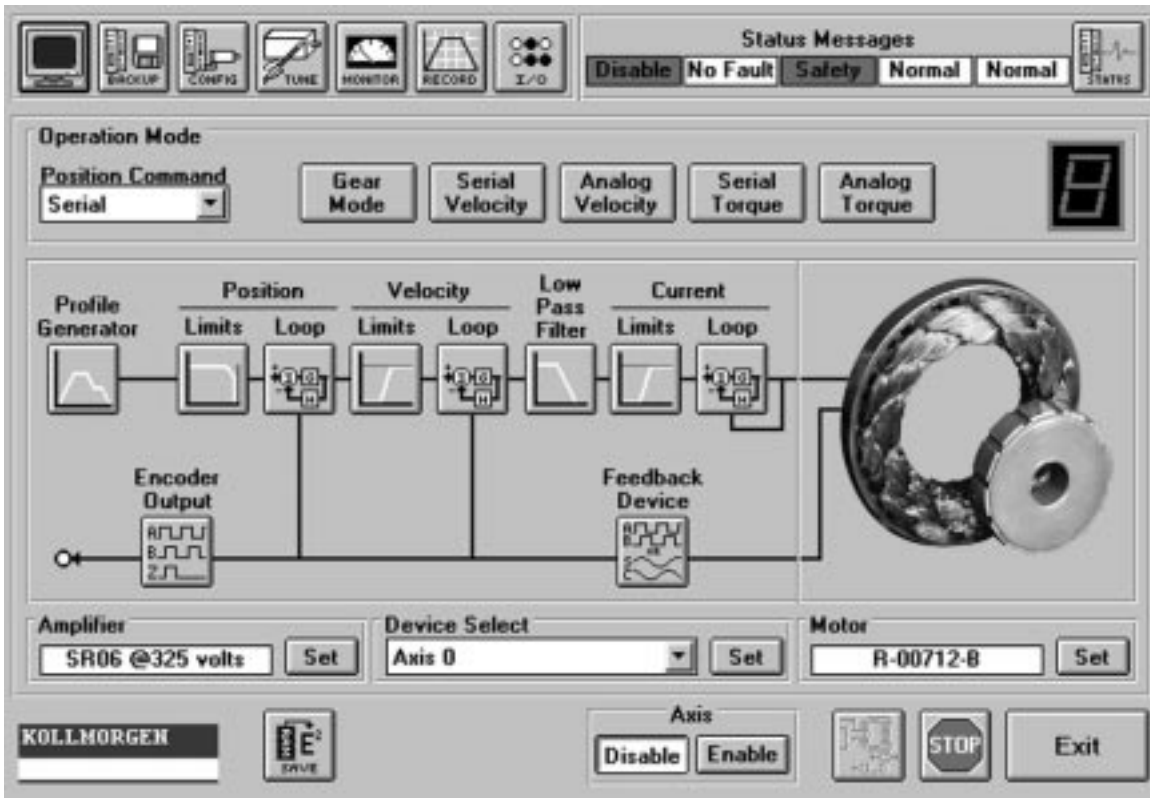

PC Oscilloscope: For closely evaluating system performance MOTIONLINK includes the functionality of an oscilloscope. You can very easily excite the load then review performance graphically on your computer screen.

Direct Terminal Mode: This mode turns your computer into a “dumb terminal.” Variables or parameters can be monitored and changed using the SERVOSTAR’s command language. This mode is ideal for advanced users who want to get directly in the “heart” of the SERVOSTAR.



Selectable Tuning Algorithms: No one control scheme is ideal for all applications. SERVOSTAR has three control schemes to choose from: Pole Placement (Standard), PI, and PDF. Although the Pole Placement will meet the needs of most applications, PI and PDF control is also available. So whether your critical need is steady speed control, high accelerations or quick response to load variations, etc., SERVOSTAR provides the greatest opportunity to achieve the best machine performance.

Monitor Mode: Allows you to jog the motor to monitor key operation variables. Speed and torque can be viewed in real time in linear gauge format. Up to three variables can be monitored at a time.

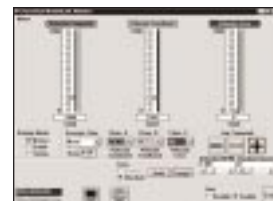

MOTIONLINK includes many other features like:

- Setting resolution of encoder “equivalent” output
- Activating position limits
- Displaying amplifier status
- Setting acceleration amps
- Limiting max speed or torque

PROGRAMMABLE FUNCTIONS

SERVOSTAR can be programmed and monitored using MOTIONLINK®, a “dumb” terminal, or from a PC, PLC, or motion controller that is running the machine.

Function	Programmable	Monitor
Amplifier Command Options (Op Modes)	Serial Velocity, Analog Velocity, Serial Torque, Analog Torque, Serial Position, Analog Position Electronic Gearing or Pulse Following	Present Operating Mode
Motor Torque Control	Peak Current, Continuous Current, Motor Current Command	Actual Motor Torque
Motor Velocity Control	Accel/Decel Rates, Accel/Decel Ramp, Jog, Stop, Max Speed, Step	Actual Motor Velocity
Motor Position Control	Max Position Error, Travel Limits, In Position Tolerance	Following Error, Move Complete
Motor Type	Linear or Rotary	
Amplifier Configuration and Status	Analog Scaling, Offset and Deadband, Drive Configuration Parameters	Travel Limit Switch Status, Drive Status, Fault Relay Status, Error Messages, Firmware Version, Amplifier Run Time
Amplifier Enabling/Disabling	Enable, Disable, Active Disable, Kill, Decelerate at Preset Rate	Drive Enabled and Power Applied to Motor, Any Faults Present
Velocity Loop Set Up	Three Compensation Types: PI, PDFF, Pole Placement plus input filter	Status of all Tuning Parameters
Position Loop Set Up	Proportional Gain	Status of all Tuning Parameters
Motor Parameters (Note: For Standard Motors Motors this Information Stored in MOTIONLINK® and can be Stored in E ² PROM when Shipped From Factory)	Name, Back EMF Constants, Resistance, Current Ratings, Number of Poles, Max Speed, Inertia, Torque Constant, Inductance, Resolver or Encoder Parameters	Status of all Motor Parameters Stored in Amplifier
Digital “Oscilloscope”	Record Functions	Motor Velocity, Current or Position
Serial Communication Protocol	Character Echo, System Prompt, Enable Power Up Receive Error Messages, Suspend / Restart Transmission	Multi-drop Address Hardware Setting
Motor Thermostat	How Amplifier Responds When Motor Thermostat Trips	Thermostat Status
Input Filter	Corner Frequency	
Active Disable (Brake Output)	Trigger Speed, Delay Time	
Gear Mode	Ratio, Type: Encoder Follower Edge and Direction, Pulse and Direction, Up/Down	Position or Velocity of Master Pulse Train or Encoder
Analog Position Command Mode	Signal Filtering, Analog Scaling, Slew Control	
Homing	Homing Speed and Direction	
Stop Mode (Quick Decel on Bus Loss)	Motor Decel Current	
Motion Command	Incremental or Absolute Moves: Set Distance and Velocity	In Position

Programmable I/O

Name	Description
Digital Inputs (IN1-IN3)	Each input can be configured to: CW Limit Switch, CCW Limit Switch, Gear Enable, Start Motion, Second Current Limit, Change Velocity to Torque Mode, Home Switch, Search for Home Switch, Move to Home Switch, Registration Capture, Active Disable, Control Fault Relay, Hold Position Also, by using two inputs, four stored index distances or speeds can be commanded
Analog Output (AOUT)	Configurable to one of the following: Motor Velocity, Motor Torque, Velocity Error, Position Following Error, Torque Command
Digital Output (DOUT)	Configurable to one of the following: Speed Exceeded, Current Exceeded, Amplifier in Foldback, Brake Enable, Motion Complete, In Position, Zero Speed Detect

Kollmorgen RBE and SERVOSTAR

SYSTEM SUMMARY INFORMATION

System Summary

Motor	Feedback	Continuous Torque oz-in (N-m)	Peak Torque oz-in (N-m)	Continuous Power Watts	Max Speed RPM	Amplifier	Amplifier Cont. Peak Current Rating (RMS/Phase)	Curve Number
RBE-00714-B	Resolver	35.3 (0.249)	80.0 (0.565)	112	6000	Sx03	3/6	1
RBE-01215-B	Resolver	92.7 (0.655)	204 (1.44)	201	4500	Sx03	3/6	2
RBE-01810-B	Resolver	60.8 (0.429)	156 (1.11)	112	3000	Sx03	3/6	3
RBE-01813-B	Resolver	219 (1.55)	449 (3.17)	321	3000	Sx03	3/6	4
RBE-01815-B	Resolver	305 (2.15)	668 (4.72)	410	3000	Sx03	3/6	5
		lb-ft (N-m)	lb-ft (N-m)					
RBE-03010-C	Resolver	2.21 (3.00)	4.42 (6.00)	701	2900	Sx03	3/6	6
RBE-03013-A	Resolver	7.19 (9.8)	16.0 (21.7)	1120	1700	Sx06	6/12	7
RBE-04512-A	Resolver	15.9 (21.5)	39.1 (53.0)	2410	2200	Sx20	20/40	8
RBE-06212-A	Resolver	28.9 (39.2)	74.2 (101)	2700	1000	Sx20	20/40	9

1 ■ Motor RBE-00714-B ■ Amplifier Sx03 ■ Bus Voltage 325 VDC

Performance Specification	Symbol	Units	
Cont. Torque at stall	Tc	oz-in N-m	35.3 0.249
Peak Torque at stall	Tp	oz-in N-m	80.0 0.565
Cont. Power	HP rated W rated	HP Watts	0.15 112
Max. Speed	N	RPM	6000
Motor Inertia x 10 ⁴	Jm	oz-in-s ² kg-m ²	4.40 0.0311
Motor Weight	Wt	oz kg	8.9 0.252

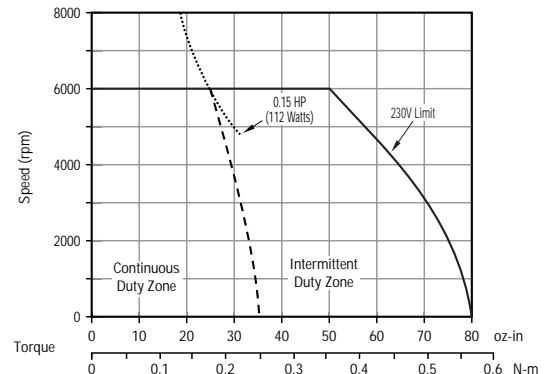

2 ■ Motor RBE-01215-B ■ Amplifier Sx03 ■ Bus Voltage 325 VDC

Performance Specification	Symbol	Units	
Cont. Torque at stall	Tc	oz-in N-m	92.7 0.655
Peak Torque at stall	Tp	oz-in N-m	204 1.44
Cont. Power	HP rated W rated	HP Watts	0.27 201
Max. Speed	N	RPM	4500
Motor Inertia x 10 ⁴	Jm	oz-in-s ² kg-m ²	40.0 0.282
Motor Weight	Wt	oz kg	22.0 0.624

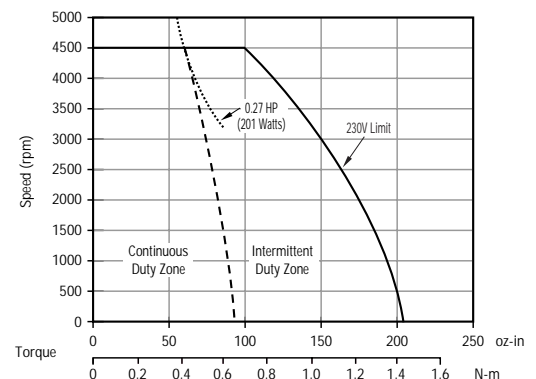

Note: Continuous duty operation is based on the amount of heat sinking provided and may vary from the indicated value. Contact the Kollmorgen Customer Support Network for assistance in product selection.

Kollmorgen RBE and SERVOSTAR

SYSTEM SUMMARY INFORMATION

3 ■ Motor RBE-01810-B ■ Amplifier Sx03 ■ Bus Voltage 325 VDC

Performance Specification	Symbol	Units	
Cont. Torque at stall	Tc	oz-in	60.8
		N-m	0.429
Peak Torque at stall	Tp	oz-in	156
		N-m	1.11
Cont. Power	HP rated	HP	0.15
	W rated	Watts	112
Max. Speed	N	RPM	3000
Motor Inertia x 10 ⁴	Jm	oz-in-s ²	51.0
		kg-m ²	0.360
Motor Weight	Wt	oz	12.0
		kg	0.340

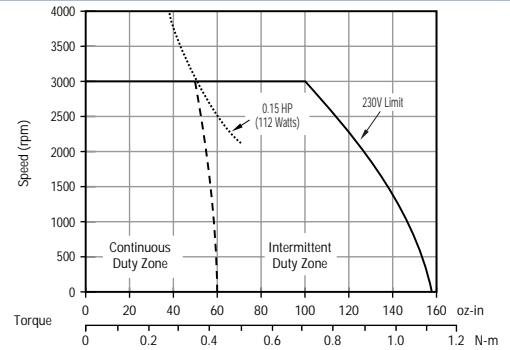

4 ■ Motor RBE-01813-B ■ Amplifier Sx03 ■ Bus Voltage 325 VDC

Performance Specification	Symbol	Units	
Cont. Torque at stall	Tc	oz-in	219
		N-m	1.55
Peak Torque at stall	Tp	oz-in	449
		N-m	3.17
Cont. Power	HP rated	HP	0.43
	W rated	Watts	321
Max. Speed	N	RPM	3000
Motor Inertia x 10 ⁴	Jm	oz-in-s ²	155
		kg-m ²	1.09
Motor Weight	Wt	oz	34.5
		kg	0.977

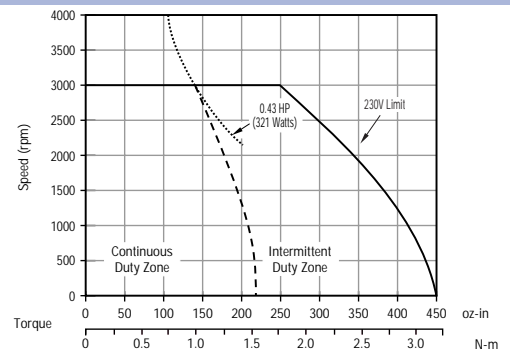

5 ■ Motor RBE-01815-B ■ Amplifier Sx03 ■ Bus Voltage 325 VDC

Performance Specification	Symbol	Units	
Cont. Torque at stall	Tc	oz-in	305
		N-m	2.15
Peak Torque at stall	Tp	oz-in	668
		N-m	4.72
Cont. Power	HP rated	HP	0.55
	W rated	Watts	410
Max. Speed	N	RPM	3000
Motor Inertia x 10 ⁴	Jm	oz-in-s ²	223
		kg-m ²	1.57
Motor Weight	Wt	oz	49.1
		kg	1.39

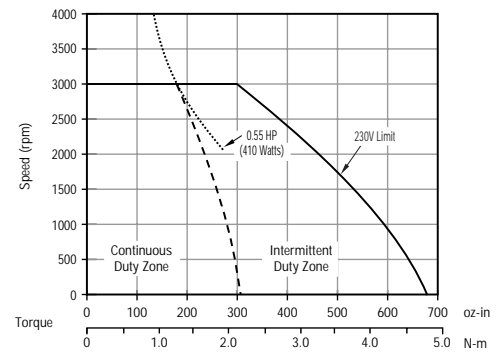

6 ■ Motor RBE-03010-C ■ Amplifier Sx03 ■ Bus Voltage 325 VDC

Performance Specification	Symbol	Units	
Cont. Torque at stall	Tc	lb-ft	2.21
		N-m	3.00
Peak Torque at stall	Tp	lb-ft	4.42
		N-m	6.00
Cont. Power	HP rated	HP	0.94
	W rated	Watts	701
Max. Speed	N	RPM	2900
Motor Inertia x 10 ⁴	Jm	lb-ft-s ²	0.583
		kg-m ²	0.791
Motor Weight	Wt	lb	2.2
		kg	1.0

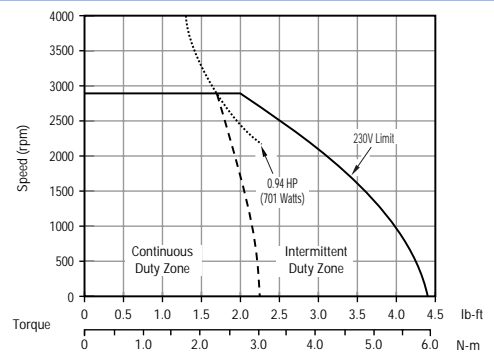

Note: Continuous duty operation is based on the amount of heat sinking provided and may vary from the indicated value. Contact the Kollmorgen Customer Support Network for assistance in product selection.

Kollmorgen RBE and SERVOSTAR

SYSTEM SUMMARY INFORMATION

7 ■ Motor RBE-03013-A ■ Amplifier Sx06 ■ Bus Voltage 325 VDC

Performance Specification	Symbol	Units	
Cont. Torque at stall	Tc	lb-ft	7.19
		N-m	9.8
Peak Torque at stall	Tp	lb-ft	16.0
		N-m	21.7
Cont. Power	HP rated	HP	1.5
		W rated	Watts
Max. Speed	N	RPM	1700
Motor Inertia x 10 ⁴	Jm	lb-ft-s ²	6.67
		kg-m ²	9.04
Motor Weight	Wt	lb	3.9
		kg	1.79

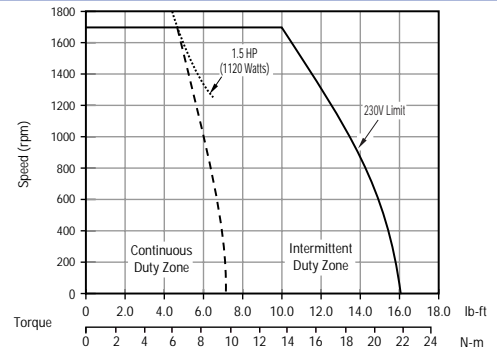

8 ■ Motor RBE-04512-A ■ Amplifier Sx20 ■ Bus Voltage 325 VDC

Performance Specification	Symbol	Units	
Cont. Torque at stall	Tc	lb-ft	15.9
		N-m	21.5
Peak Torque at stall	Tp	lb-ft	39.1
		N-m	53.0
Cont. Power	HP rated	HP	3.23
		W rated	Watts
Max. Speed	N	RPM	2200
Motor Inertia x 10 ⁴	Jm	lb-ft-s ²	34.0
		kg-m ²	46.1
Motor Weight	Wt	lb	15
		kg	6.8

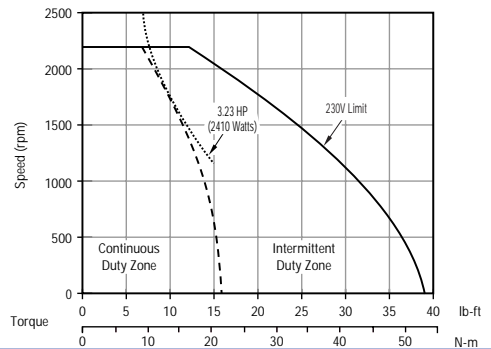

9 ■ Motor RBE-06212-A ■ Amplifier Sx20 ■ Bus Voltage 325 VDC

Performance Specification	Symbol	Units	
Cont. Torque at stall	Tc	lb-ft	28.9
		N-m	39.2
Peak Torque at stall	Tp	lb-ft	74.2
		N-m	101
Cont. Power	HP rated	HP	3.62
		W rated	Watts
Max. Speed	N	RPM	1000
Motor Inertia x 10 ⁴	Jm	lb-ft-s ²	111.0
		kg-m ²	150.0
Motor Weight	Wt	lb	25.6
		kg	11.6

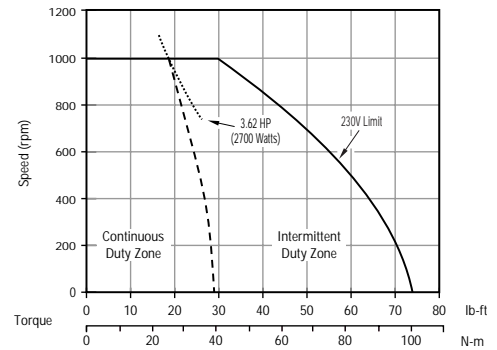

Note: Continuous duty operation is based on the amount of heat sinking provided and may vary from the indicated value. Contact the Kollmorgen Customer Support Network for assistance in product selection.

System summaries represent only a small number of possible RBE / SERVOSTAR combinations. Other motor frame sizes and stack lengths are available. Contact the Kollmorgen Customer Support Network for assistance.

Kollmorgen RBE and SERVOSTAR

AMPLIFIER SPECIFICATIONS

Electrical characteristics

- Closed loop velocity bandwidth up to 400 Hz
- Motor current ripple frequency:
 - 32 kHz (3/10 amp models)
 - 16 kHz (20/30/55 amp models)
- Analog command: 14 bit resolution
- Long term speed regulation (0.01%)
- Position loop update rate 500 μ sec (2 kHz)
- Velocity loop update rate 250 μ sec (4 kHz)
- Commutation update rate 62.5 μ sec (16 kHz) (for smooth sinusoidal commutation)
- Current loop update rate 62.5 μ s (16 kHz)

Fault protection

- Output phase to phase short circuit protection
- Overvoltage
- Undervoltage
- Overtemperature (motor and amplifier)
- Overspeed
- Overcurrent
- Feedback loss
- Foldback

Environmental

- Operation range
 - Ambient 0 to 45°C (derated above ambient)
 - Storage -20°C to 70°C
- Humidity (non-condensing) 10% to 90%

Digital compensation

- Velocity loop: PI, PDF or Pole Placement selectable algorithms
- Factory preset or field tunable
- **MOTIONLINK**® software provides tuning programming via RS-232 or RS-485 serial interface
- Position loop gain adjustment
- Digital current loop
- Adjustable filters

Inputs

- Analog command: $\pm 10V$ bit resolution up to 16,000 to 1 dynamic speed range
- Remote enable: 24V
- Three multi-purpose inputs: 24V Configurable to: CW limit switch, CCW limit switch, gear enable, start motion, second current limit, change velocity to torque mode, home switch, search for home, move to home registration capture, active disable, control fault relay, hold position plus using two inputs, up to four stored indexes or speeds can be executed
- Pulse command: up/down, pulse/direction, pulse or quadrature encoder format into RS-485 receivers or opto isolators

Communications

- RS-232 or RS-485 serial interface up to 19.2 kb

Outputs

- Fault: contact closure rated for 1 Amp, 24 Volt
- One multi-purpose output 24V configuration: speed exceeded, current exceeded, amplifier in foldback, brake enable, motion complete, in position, zero speed detect

Operational modes

- Torque control — from analog or serial command
- Velocity control — from analog or serial command
- Pulse following
- Gearing from quad encoder input
- Position control from analog or serial command

Diagnostics

- Seven segment LED display
- Error history log
- Internal variable monitoring
- DC scope

Motor Feedback

- Resolver: sine/cosine 2V peak to peak (SERVOSTAR provides 4.25V peak to peak for resolver excitation)
- Encoder: 5V quadrature with or without Halls, with or without marker

Amplifier Ratings

Model	DC Bus Voltage Input (VDC)	Output Continuous Current Per Phase (RMS/phase)	Output Peak Current Per Phase (RMS/phase) (2 sec)	Output Continuous Power (kW)	Internal Power Dissipation (Watts)	PWM Switching Frequency (kHz)
Sx03	110 to 360	3	6	1.1	37	16
Sx06	110 to 360	6	12	2.2	84	16
Sx10	110 to 360	10	20	3.6	120	16
Sx20	125 to 360	20	40	7.3	240	8

Kollmorgen RBE and SERVOSTAR

POWER SUPPLY SPECIFICATIONS

SERVOSTAR Power Supply Specifications and Sizing

Model	AC Line Input Voltage +/-10% (VAC)	Main Input Current Continuous Per Phase (RMS)	Main Input Current Peak Per Phase (RMS) 2 sec	Rated Input Power (kVA)	Rated Output Power (kW)	Standard Regen (Watts) Internal (External)	Internal Dissipation (Watts)
PA08	115 1Ø 230 1Ø 230 3Ø	8	16	0.92 1.8 3.2	0.67 1.3 2.4	Capacitive Only	45
PA14	115 1Ø	14	28	1.6	1.1	40W (200W)	70
PA28	230 1Ø 230 3Ø	14 28	56 56	6.4 11.2	2.4 8.7	40W (400W)	130
PA50	230 3Ø	50	100	20	15.5	None (500W or 1000W)	200
PA75	230 3Ø	75	150	30.0	23.3	None (500W to 2000W)	275
PA85	230 3Ø	85	170	34.0	76.4	None (500W to 2000W)	320
PA-LM	100-230 1Ø	N/A	N/A	N/A	N/A	N/A	7

Protective features

- Soft start circuitry
- Overtemperature

Environmental

- Operating ambient temperature 0 to 45°C (derated above ambient)

- Storage temperature -20° to 70°C
- Humidity (non-condensing) 10% to 90%

PA Series Power Supply Sizing

SERVOSTAR amplifiers perform as power converters generating three-phase sinewave current by pulse-width modulating a high-voltage DC bus. PA Series power supplies produce DC Bus and low voltage logic power for up to four SERVOSTAR amplifiers.

DC Bus Power

The output power rating of the supply must exceed or equal the combined average power of all servo drives operating simultaneously. Average power of an individual servo drive is based on a power calculation of RMS torque and speed. The power supply output rating takes into account losses and power factor such that no further derating is needed with respect to the motor output power.

$$\text{Power (Watts)} = \frac{N(\text{RPM}) \times T(\text{lb-ft})}{7.04}$$

or

$$\text{Watts} = \frac{N(\text{RPM}) \times T(\text{N-m})}{9.55}$$

Logic Power (for SxXX200 models)

In addition to the power requirement, each power supply has a maximum axis configuration based on logic supply requirements of individual SERVOSTAR amplifiers. The PA08 and PA14 have a logic supply rated for up to two SERVOSTAR amplifiers. All other power supplies can drive up to four axes of SERVOSTAR amplifiers (See Maximum Axes Configuration Chart). See Application Note A-SU-000-H for more detail on power supply sizing, or use MOTIONEERING software. *

PA-LM Logic Only Power Supply

The PA-LM logic only power supply is designed to complement Kollmorgen's existing line of PA power supplies. It produces the

Power Supply Model	Maximum Number of SERVOSTAR Amplifiers	
	Without PA-LM Logic Module	With PA-LM* Logic Module
PA08	up to 2	up to 4
PA14	up to 2	up to 4
PA28	up to 4	up to 6
PA50	up to 4	up to 6
PA75	up to 4	up to 6
PA85	up to 4	up to 6

*The PA-LM contains logic power for two Sx03, Sx06 or Sx10 Amplifier or one Sx20, Sx30 or Sx55 Amplifier

logic power required to operate up to two axis of SERVOSTAR amplifiers. This allows an increase in the axis capability of a PA power supply.

Resistive Regeneration Sizing

Shunt regeneration is required to dissipate energy that is pumped back into the DC bus during load deceleration. The amount of shunt regeneration required is a function of the sum of simultaneously decelerating loads. The loads need to be defined in terms of system inertia, maximum speed, and deceleration time. In addition, the duty cycle must be known. Application Note A-SU-001-H details a calculation method to determine proper regeneration sizing, or use MOTIONEERING software. *

Transformer Sizing

(Required only for voltage matching)

PA Series power supplies can be connected to a line. Built-in soft-start circuitry protects power supply components and eliminates nuisance tripping of breakers or fuse blowing due to large in-rush currents. Transformers are only required for voltage matching purposes. In this case, the transformer should have a 115 or 230 VAC secondary depending on the operating voltage. The kVA rating of the transformer should take into account not only the servo output load requirements but also losses in the system and power factor. The transformer should have a kVA rating no less than the input kVA rating of the power supply if the full supply rating is being utilized.

If the full output power of the power supply is not needed, the following calculation can be used:

$$\text{KVA} = \frac{\text{Load Power (Watts)}}{.75 (1000)}$$

* MOTIONEERING, Kollmorgens application sizing software, incorporates algorithms to quickly select the optimum motor and drive as well as determine power supply and shunt regeneration requirements.

CONNECTOR INFORMATION

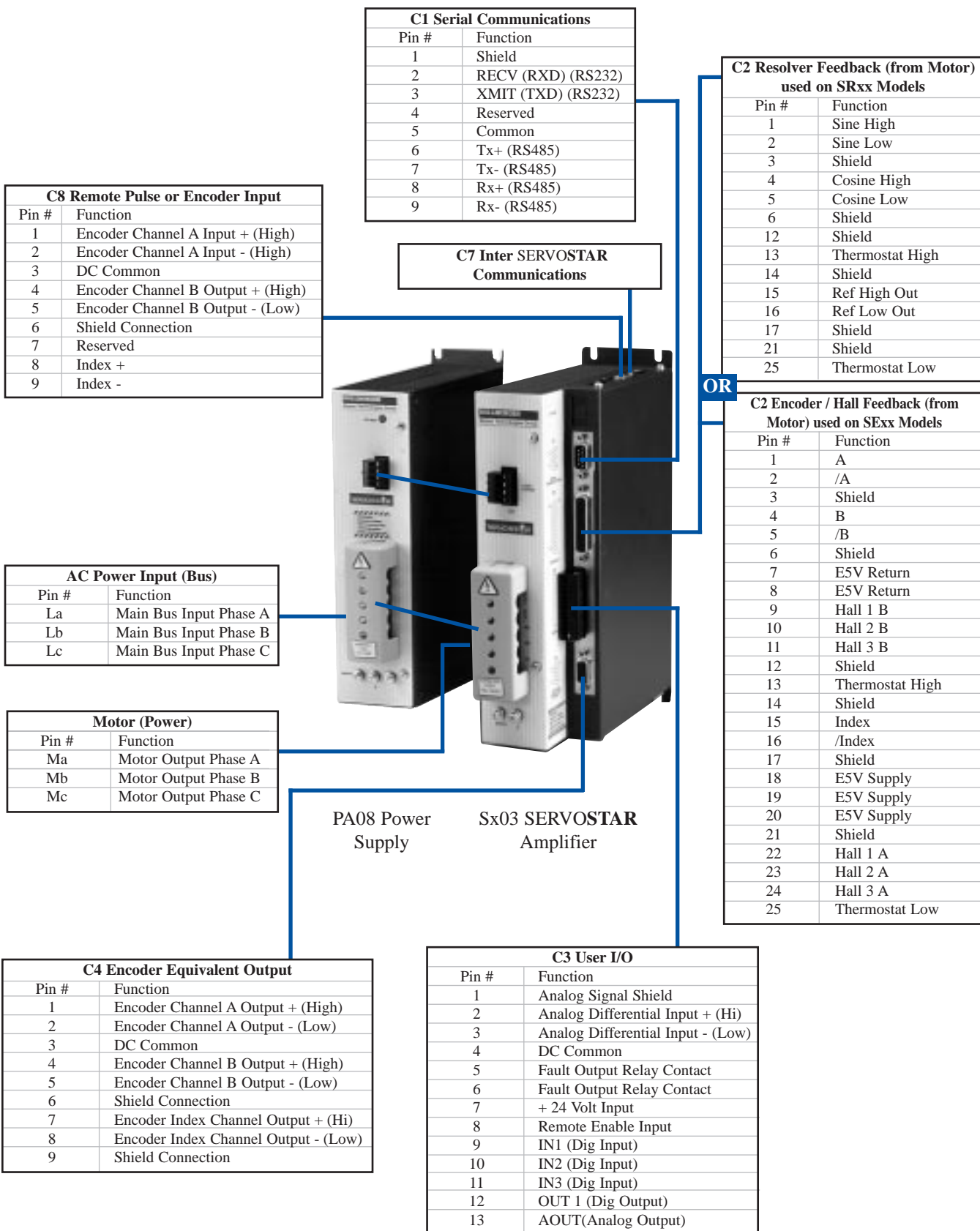

DIMENSIONS

SR03/06/10/20 Amplifier

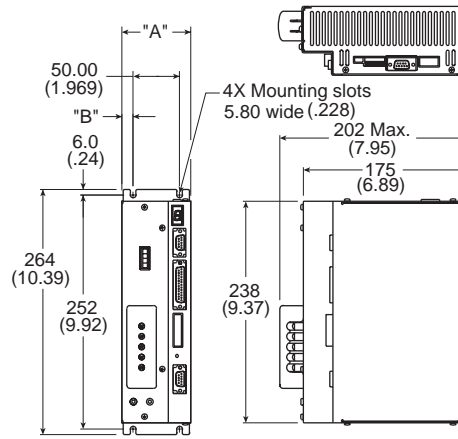

Dimensions in mm (inches)

	A	B
SR03	75 (2.91)	12.5 (0.49)
SR06	75 (2.91)	12.5 (0.49)
SR10	90 (3.54)	20 (0.79)
SR20	119 (4.67)	34.3 (1.35)

PA08 Power Supply

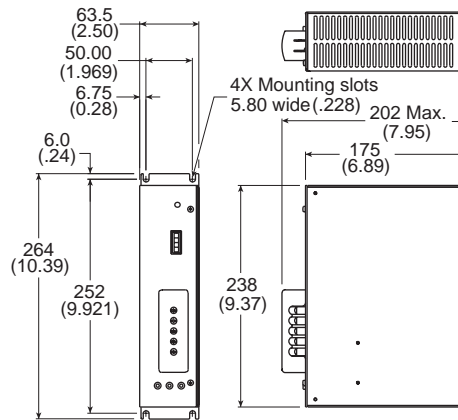

Dimensions in mm (inches)

PA14/28 Power Supply

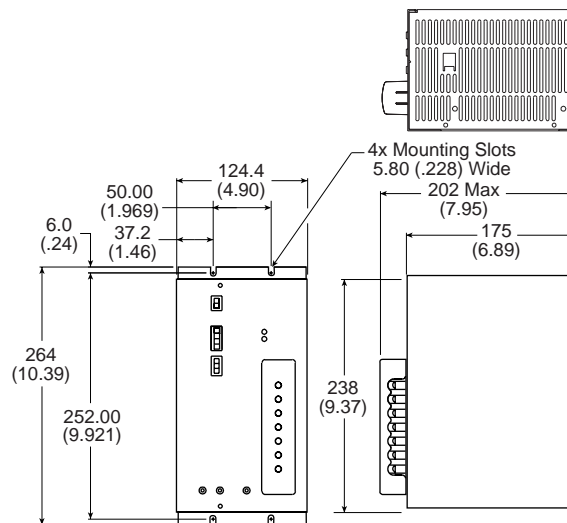

Dimensions in mm (inches)

DIMENSIONS

PA50/75/85 Power Supply

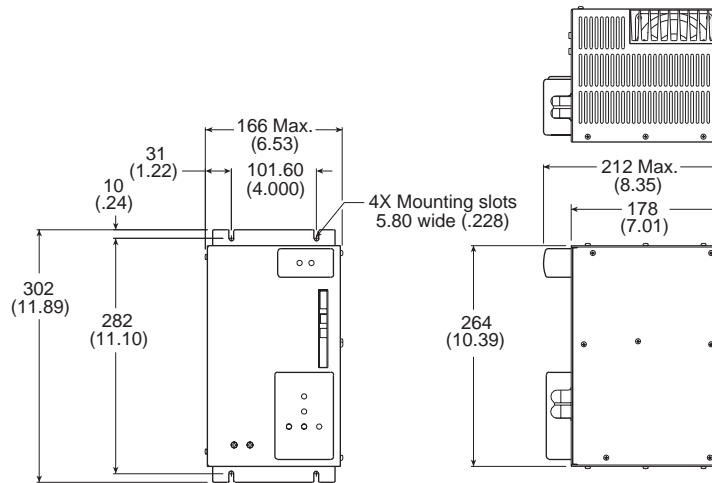

Dimensions in mm (inches)

PA-LM Logic Power Supply

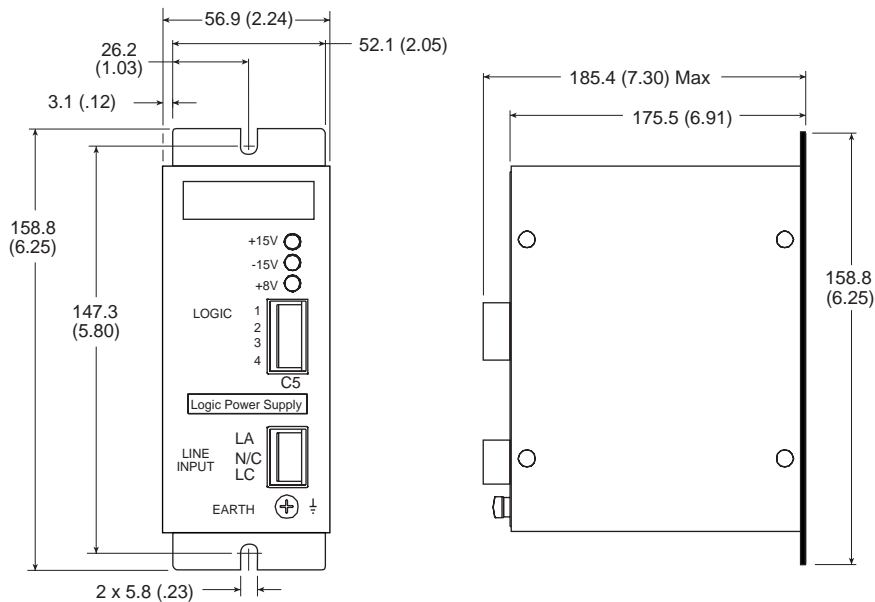

Dimensions in mm (inches)

DIMENSIONS

ER-20 / ER-21 / ER-22 / ER-23

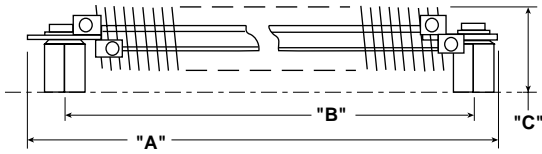

Resistor Model	"A"	"B"	"C"
ER-20	454.2 (17.88)	412.8 (16.25)	55.6 (2.19)
ER-21	692.2 (27.25)	660.4 (26.0)	55.6 (2.19)
ER-22	454.2 (17.88)	412.8 (16.25)	127 (5.00) Max.
ER-23	692.2 (27.25)	660.4 (26.0)	127 (5.00) Max.

ER-20 / ER-21

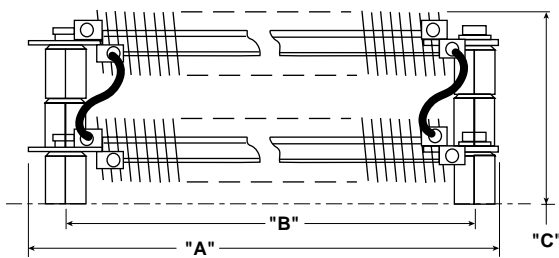

ER-20 / ER-21

*Bottom standoffs are threaded 1/4-20 x 3/8" dp. for mounting resistors to panels, etc.

Overload Relay used with ER-20 / ER-21 / ER-22 / ER-23

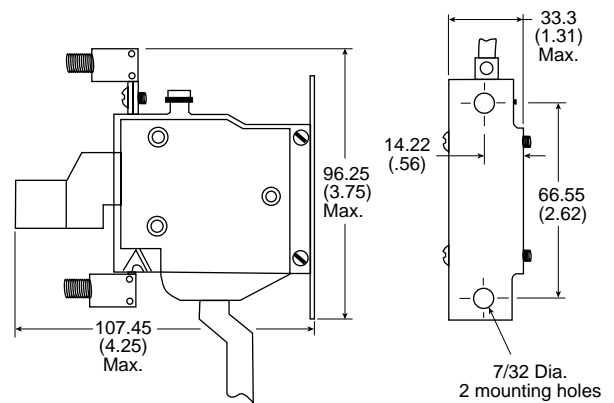

Dimensions in mm (inches)

ER-30 / ERH-40

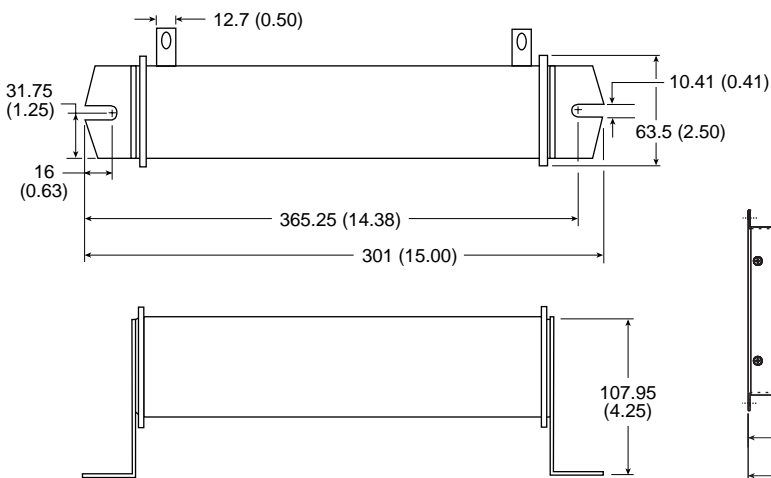

ER-30

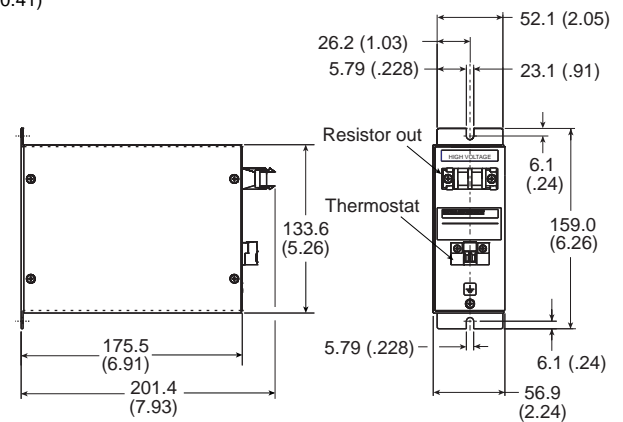

ERH-40

Dimensions in mm (inches)

Kollmorgen RBE

DIMENSIONS

RBE-00714-00

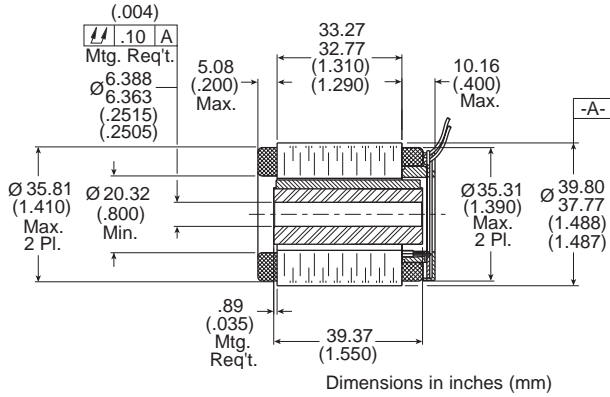

RBE-01215-00

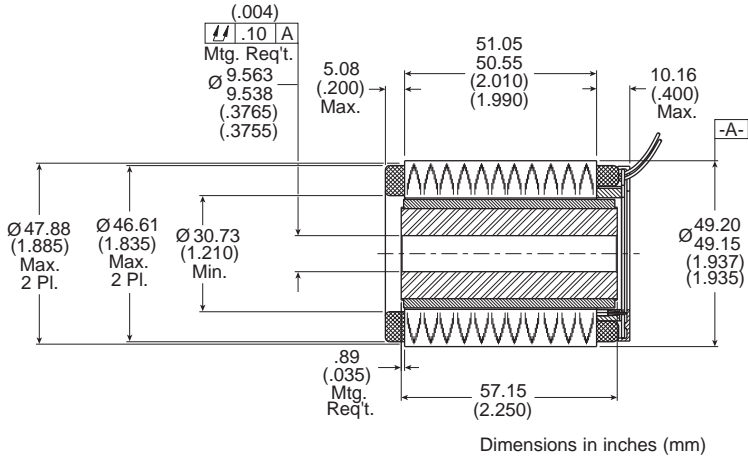

RBE-0181X-00

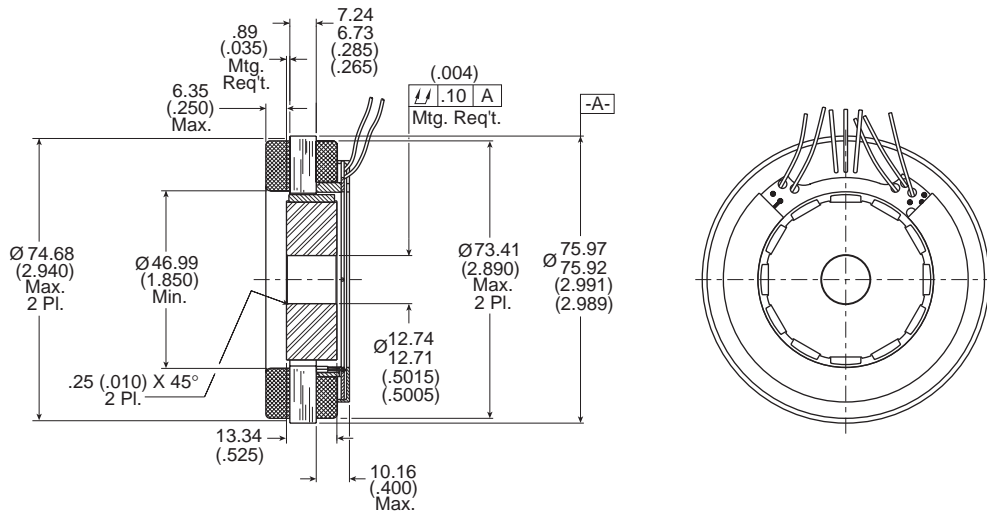

RBE	A	B
-01810	6.99 (.275)	13.34 (.525)
-01813	30.73 (1.21)	37.08 (1.46)
-01815	46.23 (1.82)	53.34 (2.10)

Dimensions in inches (mm)

DIMENSIONS

RBE-0301X-00

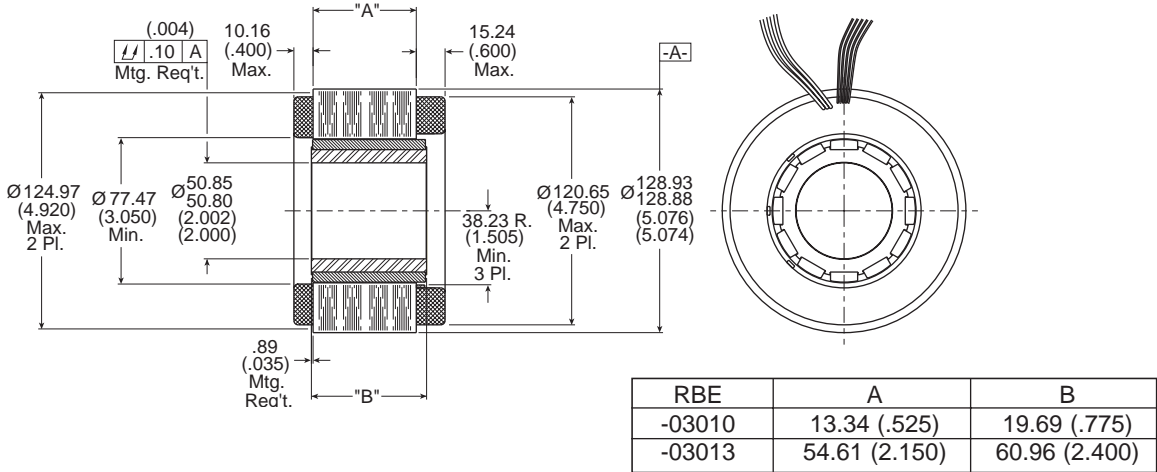

Dimensions in inches (mm)

RBE-004512-00

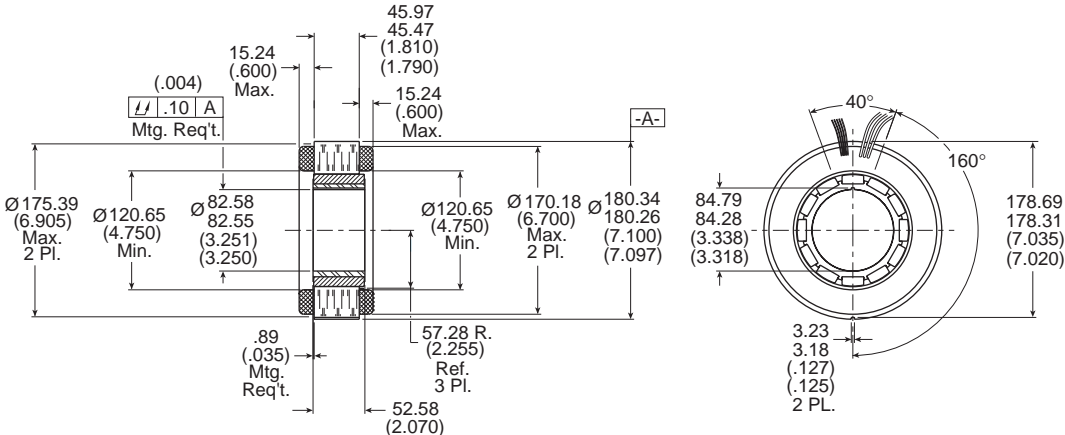

Dimensions in inches (mm)

RBE-06212-00

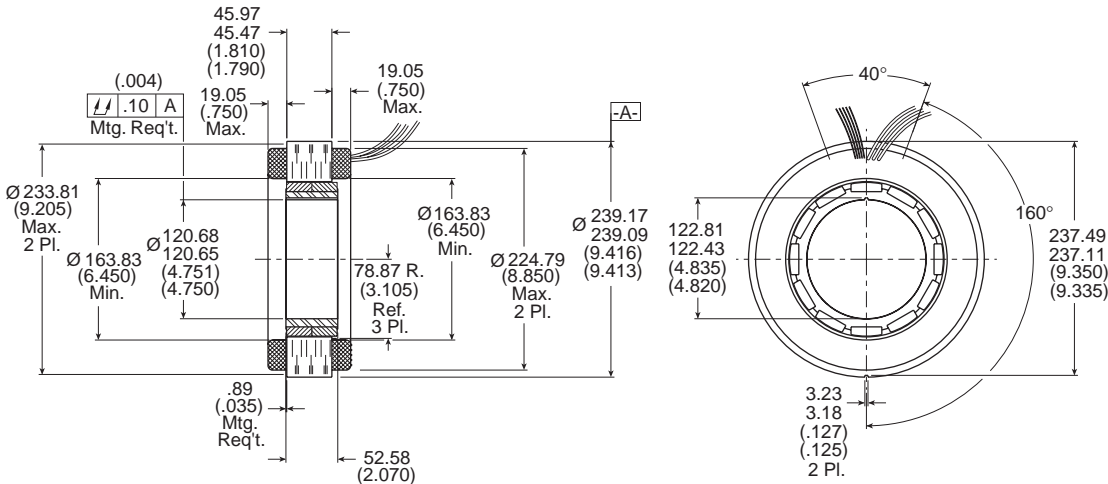

Dimensions in inches (mm)

Kollmorgen RBE

SYSTEM INTERCONNECT DIAGRAM AND ORDERING INFORMATION

SYSTEM INTERCONNECT DIAGRAM

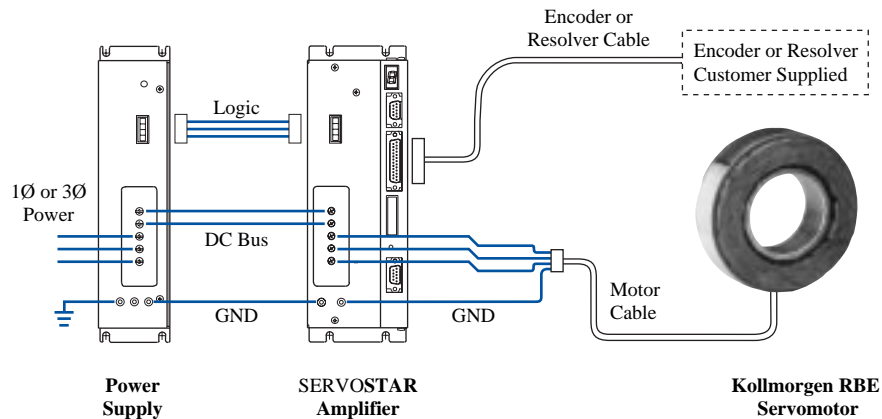

SERVOSTAR/RBE System Configurations

Amplifier	Motor	Cable Assembly	Curve Number
Sx03200-2R0714B	RBE-00714-B	CS-SS-RUA10-xx	1
Sx03200-2R1215B	RBE-01215-B	CS-SS-RUA10-xx	2
Sx03200-2R1810B	RBE-01810-B	CS-SS-RUA10-xx	3
Sx03200-2R1813B	RBE-01813-B	CS-SS-RUA10-xx	4
Sx03200-2R1815B	RBE-01815-B	CS-SS-RUA10-xx	5
Sx03200-2R3010C	RBE-03010-C	CS-SS-RUA10-xx	6
Sx06200-2R3013A	RBE-03013-A	CS-SS-RUA10-xx	7
Sx20200-2R4512A	RBE-04512-A	CS-SS-RUA20-xx	8
Sx20200-2R6212A	RBE-06212-A	CS-SS-RUA20-xx	9

Kollmorgen RBE and SERVOSTAR

SYSTEM ORDERING INFORMATION

Note: SERVOSTAR amplifiers shown on page 18 are compensated for 230 VAC (to PA power supply), bus voltage 325 VDC. “xx” designation is length in 3 meter increments, max resolver cable length is 75 meters, max encoder length is 30 meters. The amplifier / motor combinations are also available with 115 VAC (to PA power supply). To order replace the “2” with a “1” (e.g., SR03200-2G102A would be SR03200-1G102A.)

Power Supply:	PA0800	8 amp power supply (115 or 230 Volt input)
	PA1400	14 amp power supply (115 Volt input)
	PA2800	28 amp power supply (230 Volt input)
	PA5000	50 amp power supply (230 Volt input)
	PA7500	75 amp power supply (230 Volt input)
	PA8500	85 amp power supply (230 Volt input)
	PA-LM	Logic only power supply

External Regen Resistor Kit:	ER-30	400 Watts, 8.8 Ohm, for PA14 or PA28 (Limit operation with PA14 to 200 Watts)
	ERH-40	100 Watts, 8.8 Ohm (housed), for PA14 or PA28 (Limit operation with PA14 to 200 Watts)
	ER-20*	500 Watts, 4.5 Ohm, for PA50 or PA75
	ER-21*	1000 Watts, 4.4 Ohm, for PA50, PA75, or PA85
	ER-22*	1000 Watts, 2.2 Ohm, for PA75 or PA85
	ER-23*	2000 Watts, 2.2 Ohm, for PA75 or PA85

*Includes overload relay

Communications Cable: A-97251-004 RS-232 communications cable

Connector Kit: CK100 Mating connectors* for C1, C2, C4, C7 & C8
*Screw terminal mating connectors C3 and C5 are included with the SERVOSTAR amplifier.

Feedback Devices: Kollmorgen’s SERVOSTAR digital amplifiers can be configured at our manufacturing facilities for either encoder or resolver feedback. The customer will provide the feedback device and integrate it with the frameless motor (like the RBE). The feedback device should meet the following guidelines for compatibility with the SERVOSTAR Amplifier.

Encoder: Incremental A, B, Marker

Resolver: SERVOSTAR outputs 4.25 VAC at 7 kHz to resolver and requires 2VAC signal from resolver.

Note: Kollmorgen RBE systems are supplied with hall effect feedback. Screw terminal mating connectors C3 and C5 are included with the SERVOSTAR amplifier. All cable assemblies terminate with connectors to SERVOSTAR and flying leads to RBE motor. Contact the Kollmorgen Customer Support Network for more information.

Kollmorgen Sales Offices

E-mail: kmtg@kollmorgen.com

Internet: <http://www.kollmorgen.com>

Motion Technologies Group

1-800-77 SERVO

E-mail: kmtg@kollmorgen.com

Americas

Radford, VA

Tel: (800) 77 SERVO

Fax: (540) 731-0847

Europe & Middle East

Dusseldorf, Germany

Tel: (49) 203 9979 0

Fax: (49) 203 9979 155

Asia Pacific & Far East

Tianjin, China

Tel: (86) 22 2627 1090

Fax: (86) 22 2627 1093

Aerospace & Defense Group

1-800-77 SERVO

E-mail: kmtg@kollmorgen.com

Americas & Asia

Radford, VA

Tel: (540) 639-9045

Fax: (540) 731-4193

Europe, Middle East & Africa

Avrille Cedex, France

Tel: (33) 2 41 33 63 40

Fax: (33) 2 41 33 63 40

Kollmorgen Manufacturing Locations

Kollmorgen Artus

Avrillé, France

Ho Chi Minh City, Vietnam

Kollmorgen Seidel

Dusseldorf, Germany

Kollmorgen Electro-Optical

Northampton, MA

Kollmorgen Servotronics

Tel Aviv, Israel

Kollmorgen Industrial Drives

Radford, VA

Kollmorgen Tandon Inc

Bombay, India

Kollmorgen Inland Motor

Radford, VA

Kollmorgen Tianjin Industrial Drives

Tianjin, China

Kollmorgen PMI

Commack, NY

Kollmorgen enjoys a reputation of excellence based on constant endeavors to update products. Information in this brochure is subject to change.

Windows is a registered trademark of Microsoft Corporation.
Kollmorgen SERVOSTAR, MOTIONLINK, Kollmorgen GOLDLINE, Kollmorgen SILVERLINE, PLATINUM XT, and MOTIONEERING are trademarks of Kollmorgen.

KOLLMORGEN