

OFL-1515™ Open Frame Table

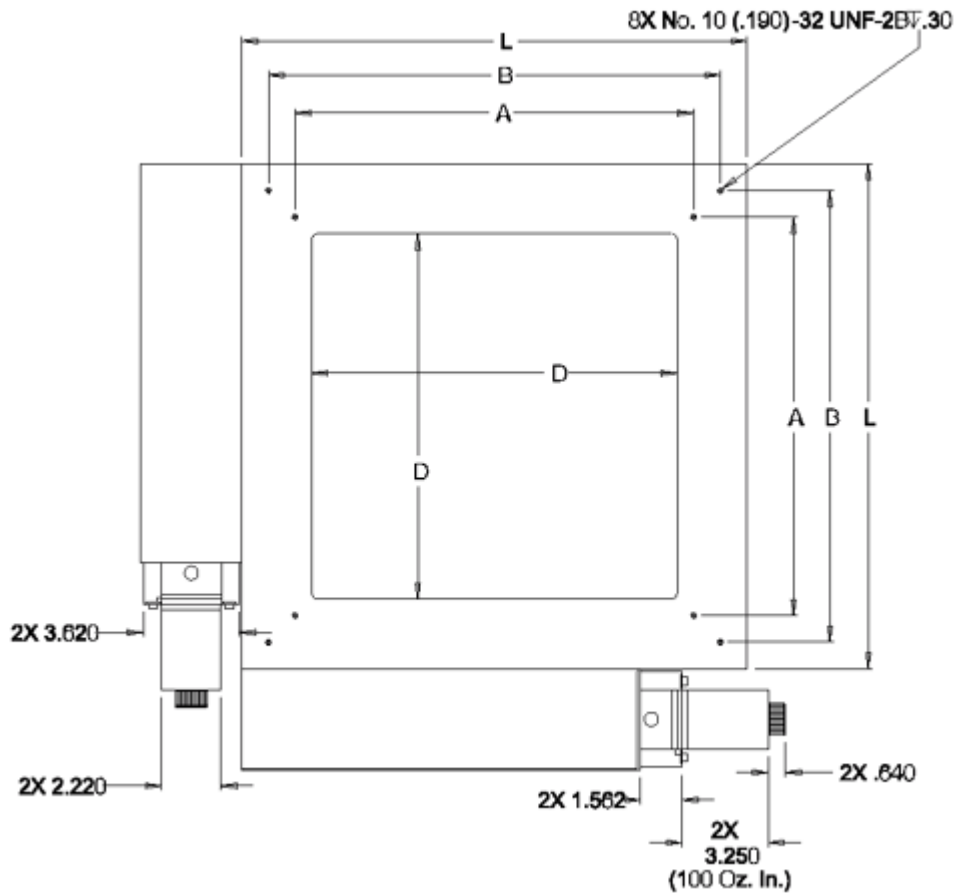

Product Dimensions

Dimensions - Top View



OFL-1515™ Open Frame Table

Dimensions - Side View

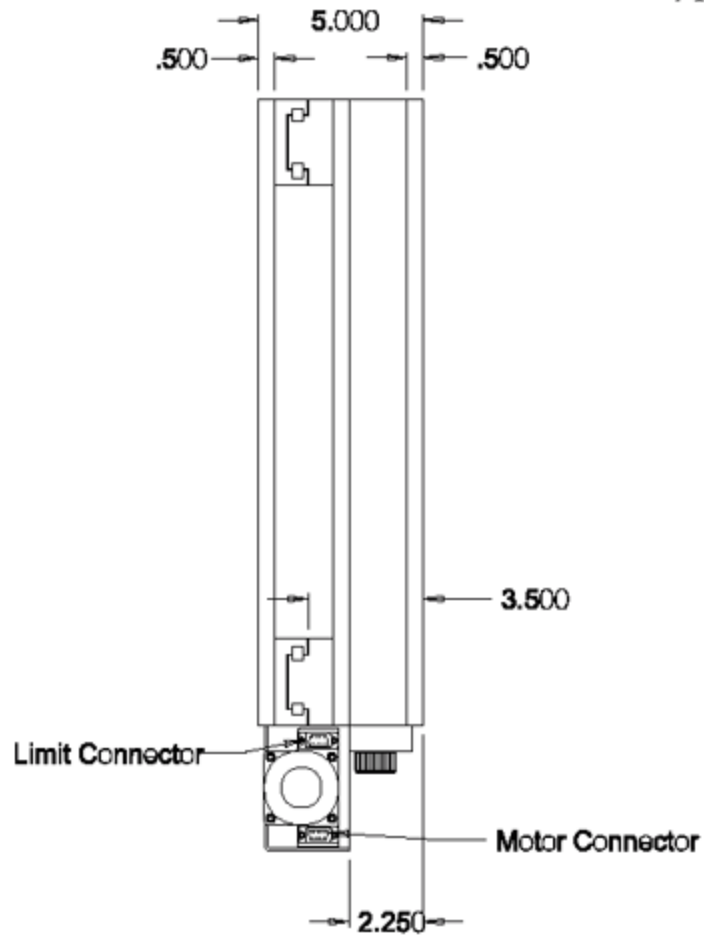

OFL-1515™ Open Frame Table

Dimensions - Bottom View

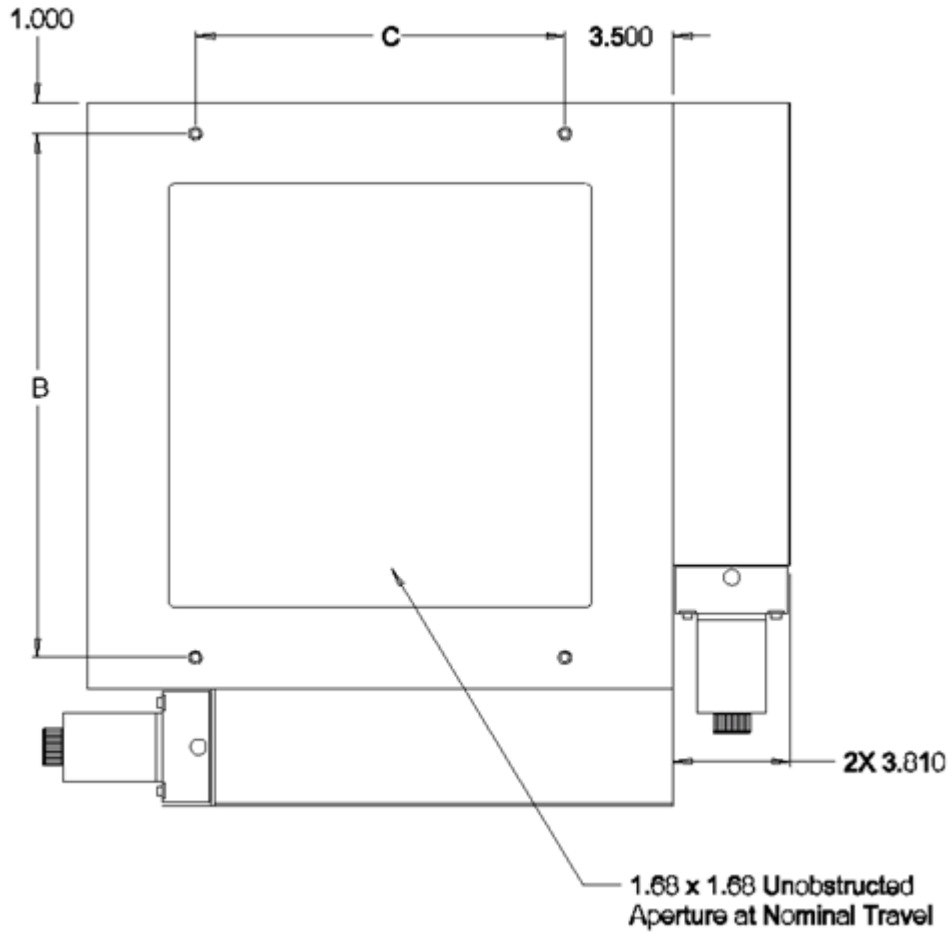

OFL-1515™ Open Frame Table

Dimensions - Moving Envelope

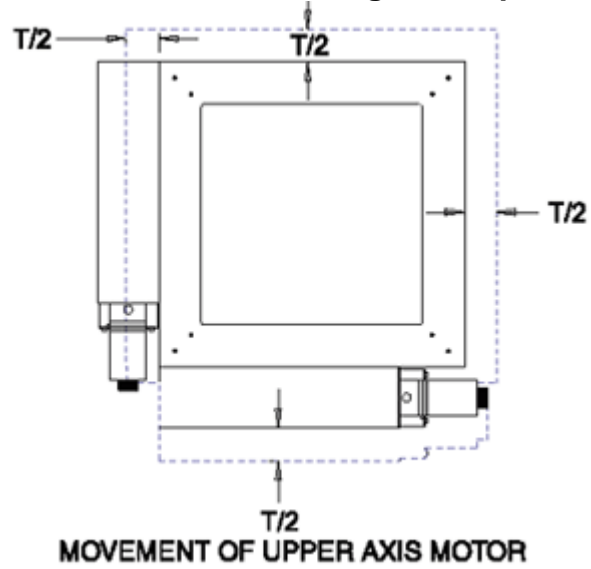

Dimensions - Perspective

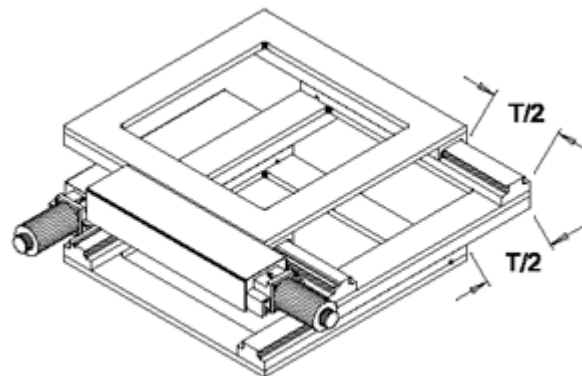

Travel (T)	Length (L)	A	B	C	D
8.00	15.00	11.000	13.000	8.000	9.750

OFL-1515™ Open Frame Table

Specifications

Travel (inches)	8 x 8	
Leadscrew Accuracy (per axis) (µm)	80	
Bidirectional Repeatability (µm)	6	
Flatness & Straightness (per axis)(µm)	15	
Orthogonality (arc-seconds)	50	
Load Capacity (kg) ¹	55	
Maximum Leadscrew Speed (rps)	15	
Moving Mass (kg)	Upper Axis Lower Axis	4.5 18.6
Total Mass (kg)	26.8	

Configurations²

Leadscrew	Lead (inch)	Precision	0.50, 0.40, 0.20, 0.10
	Lead (mm)	Precision	2
Motor	Stepper (oz-in)	400 step/rev	118, others available
		200 step/rev	100, others available
	Servo		brush, brushless

Options

Encoder	Rotary (counts/rev.)	2000, 4000
	Linear (µm/count)	5, 1, 0.5, 0.1

¹ Please contact our Applications Engineers for loads exceeding 25kg.

² Standard configuration is highlighted.