

HARDWARE REFERENCE MANUAL

MACRO CPU Board

HRM for UMAC MACRO & MACRO Stack

4Ax-602804-xHxx

June 7, 2004

For Further Information Contact

Heason Technologies Group Ltd

Tel: +44(0)1403 755800

Fax: +44(0)1403 755810

Email: sales@heason.com

Freephone 0800 374903 www.heason.com

Heason
Technologies Group



DELTA TAU
Data Systems, Inc.

NEW IDEAS IN MOTION ...

Single Source Machine Control

21314 Lassen Street Chatsworth, CA 91311 // Tel. (818) 998-2095 Fax. (818) 998-7807 // www.deltatau.com

Power // Flexibility // Ease of Use

Copyright Information

© 2003 Delta Tau Data Systems, Inc. All rights reserved.

This document is furnished for the customers of Delta Tau Data Systems, Inc. Other uses are unauthorized without written permission of Delta Tau Data Systems, Inc. Information contained in this manual may be updated from time-to-time due to product improvements, etc., and may not conform in every respect to former issues.

To report errors or inconsistencies, call or email:

Delta Tau Data Systems, Inc. Technical Support

Phone: (818) 717-5656

Fax: (818) 998-7807

Email: support@deltatau.com

Website: <http://www.deltatau.com>

Operating Conditions

All Delta Tau Data Systems, Inc. motion controller products, accessories, and amplifiers contain static sensitive components that can be damaged by incorrect handling. When installing or handling Delta Tau Data Systems, Inc. products, avoid contact with highly insulated materials. Only qualified personnel should be allowed to handle this equipment.

In the case of industrial applications, we expect our products to be protected from hazardous or conductive materials and/or environments that could cause harm to the controller by damaging components or causing electrical shorts. When our products are used in an industrial environment, install them into an industrial electrical cabinet or industrial PC to protect them from excessive or corrosive moisture, abnormal ambient temperatures, and conductive materials. If Delta Tau Data Systems, Inc. products are directly exposed to hazardous or conductive materials and/or environments, we cannot guarantee their operation.

Table of Contents

INTRODUCTION	1
3U Product Configurations (General Description)	2
MACRO CPU Specifications	3
<i>Physical Specifications</i>	<i>3</i>
<i>Electrical Specifications</i>	<i>3</i>
CONFIGURATION AND HARDWARE SETUP	5
Board Hardware Setup	5
Board Jumper and Switch Setup	6
Board Connections	7
JUMPER AND SWITCH CONFIGURATIONS.....	9
Card Layout.....	9
<i>E1: Watchdog Timer Disable</i>	<i>10</i>
<i>E2: CPU Mode Operation</i>	<i>10</i>
<i>E3: Serial Port Baud Rate</i>	<i>10</i>
<i>E4: Power Supply-Loss Control (± 15Vdc Supply Monitor).....</i>	<i>10</i>
<i>E5: MACRO Received Signal Detect/Bypass Mode (Rev -105 and 106 only).....</i>	<i>10</i>
<i>E40: MACRO Input (Fiber/Wired) Selector</i>	<i>11</i>
<i>JP3: MACRO Loop Back Test Select for Copper only (Rev -104 and Earlier)</i>	<i>11</i>
<i>JP4: Reserved for Future Use</i>	<i>11</i>
<i>JP5-JP6: MACRO Copper EQ Select (Rev -104 and Earlier).....</i>	<i>11</i>
Switch Configurations	12
<i>SW1: MACRO Slave Node Configure.....</i>	<i>12</i>
<i>SW2: MACRO Master Number Select</i>	<i>13</i>
Connector Summary.....	13
MACRO STATION CHARACTER DISPLAY	15
Hardware Re-Initialization	15
FIRMWARE UPDATES	17
BOARD CONNECTOR PINOUTS	19
J6: (JTHW) Multiplexer Port Connector.....	19
J7: (JRS232) Serial Port Connector.....	20
J14, J17: MACRO Copper I/O (Opt C).....	21
P1: UBUS Interface Connector	22
TB1: (JPWR) 4-Pin Terminal Block	22
U73: MACRO Fiber Optic Connector (Option A).....	23
HARDWARE MEMORY MAP	25
ACCESSORIES	27

INTRODUCTION

The 3U MACRO-CPU board is the processor and MACRO interface board that is used in a 3U MACRO Station (in either UMAC MACRO or MACRO Stack configuration).

Note:

Three documents describe the operation of Delta Tau Data Systems Inc. 3U MACRO Station products:

- UMAC System Manual (General Product Overview)
- 3U MACRO Station User's Manual
- 3U MACRO Station Software Reference

This manual describes the interfaces and physical hardware that is used on the 3U MACRO CPU.

The UMAC MACRO and the MACRO Stack provide a remote interface for encoders, flags, direct-PWM digital drives, analog drives, stepper drives, analog I/O, and digital I/O for Delta Tau Data's PMAC products that have a MACRO interface.

The UMAC MACRO and MACRO Stack configurations communicate with PMAC2 Ultralites or Turbo PMAC2 Ultralites solely through the MACRO ring, interfacing to standard drives, encoders, flags, and I/O through on-board connectors. This MACRO Station integrated packaging and connectivity strategy provides revolutionary flexibility and ease of use.

A 3U MACRO Station consists of a set of 3U format Euro-cards (100 x 160 mm) that can be assembled in a variety of configurations. When used in the rack configuration, connected through a backplane bus, the backplane is UBUS format, designed by Delta Tau Data Systems Inc. for motion control and I/O interfaces.

When using the fiber optic MACRO interface, the 3U MACRO Station can be up to 3 kilometers (2 miles) away from the PMAC2 controller or any other station on the ring. When using the RJ-45 copper electrical interface, it can be up to 100 meters (~330 feet) away.

The 3U MACRO Station allows PMAC2 MACRO controllers to control servo axes and I/O just as if they were directly connected to the PMAC2, even though they may be a great distance away. The only interface needed from the PMAC2 is the electrically isolated MACRO ring.

Typically, a PMAC2 Ultralite board, one without any of its own servo interface circuitry, is used with the MACRO Station to provide the most cost-effective solution.

- 3U MACRO-CPU Board (3A0-602804-10x):
- 80MHz DSP56303 CPU
- 512k x 8 flash memory for user backup and firmware
- Latest released firmware version
- RS-232 serial interface for setup and debugging
- Stack connectors for servo and I/O accessory boards
- UBUS connector for backplane connection to servo and I/O accessory boards
- JTHW multiplexed I/O port with 26-pin IDC header



The 3U MACRO Station can be configured in either of two fundamental assemblies – UMAC MACRO and MACRO Stack:

- **UMAC MACRO** – In this configuration (once called Pack) the 3U-format boards are put together to communicate through a backplane bus called the UBUS. All boards are installed in a Euro-card rack. In this configuration, all 3U-format boards or modules can be installed or withdrawn from the pack individually, providing ease of installation, debugging, and repair.

The photo at the upper right shows a UMAC rack with power supply and I/O boards that are connected through a backplane. This system allows for an easier integration of the 3U MACROCPU for larger (up to 8 axes) applications.

- **MACRO Stack** – In the Stack configuration the 3U-format boards are put together as a stack of piggyback boards, (right, below). This configuration is ideal for compact, cost-sensitive embedded applications.



UMAC MACRO Station Configuration



4 Axis Stack Configuration

Note:

The Stack boards and related breakout boards can be installed in a Euro-card rack, creating a hybrid “stack/pack” configuration. This requires a special backplane configuration that makes removing stack boards difficult.

This hybrid configuration is now recommended for existing legacy systems only.

3U Product Configurations (General Description)

Assemblies of 3U-format boards can be made with either of two CPU processor boards – a 3U MACRO CPU board, or a 3U Turbo PMAC2 CPU board. Most other 3U-format boards, labeled Accessory boards, can be used with either CPU board.

- When the 3U MACRO-CPU board is used, the resulting assemblies are called UMAC MACRO or 3U MACRO Stack.
- When the 3U Turbo PMAC2 CPU board is used, the resulting assemblies are called UMAC Turbo or Turbo Stack.

Refer to the UMAC and 3U Stack Products Selection Guide for more detailed descriptions of how the rack and stack products are integrated.

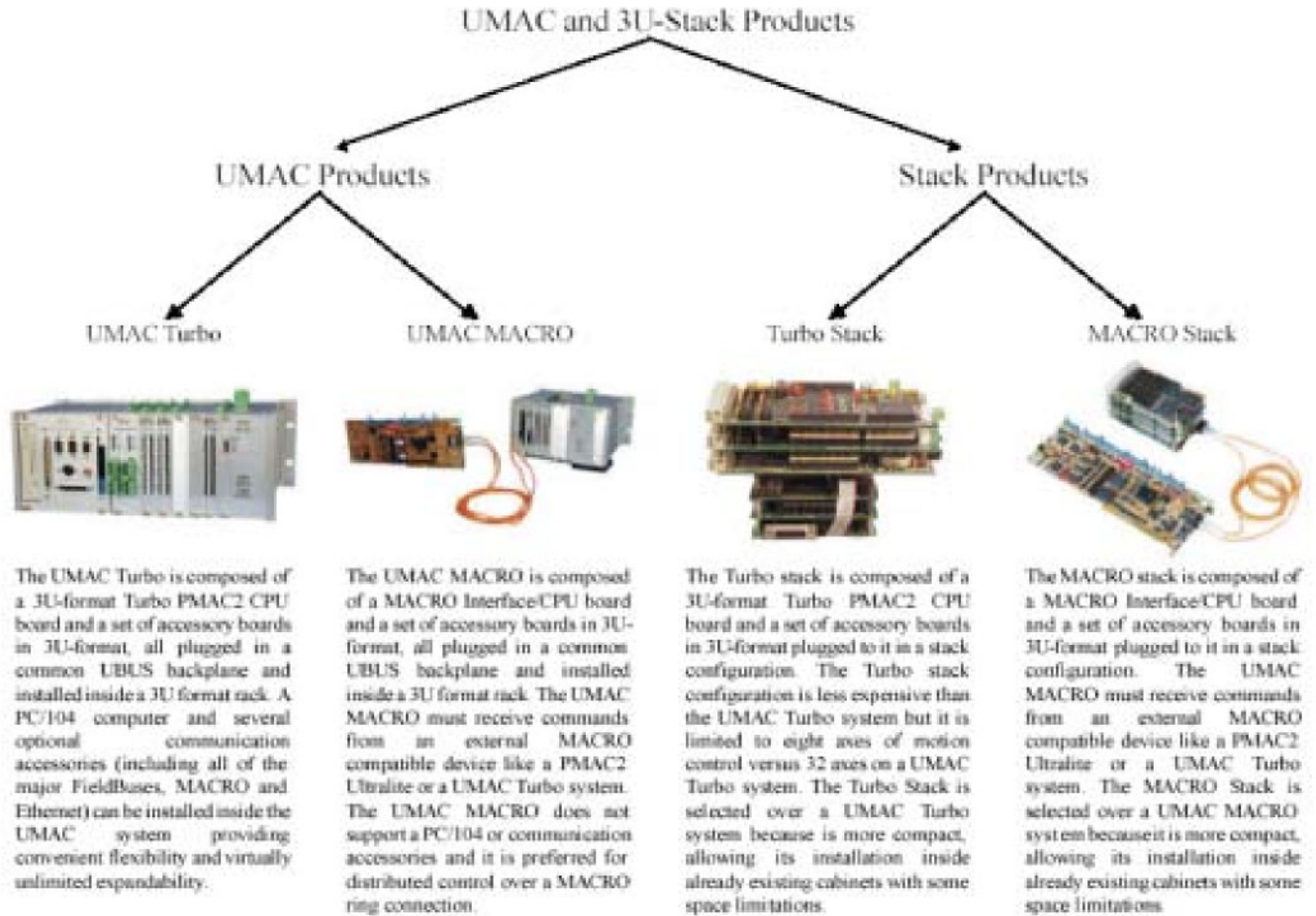

MACRO CPU Specifications

Physical Specifications

Size: 16cm x 10cm x 3.6cm (6.3" x 3.95" x 1.4")

Weight: ½ lb.

Temperature

Operating: 0°C to 60°C (32°F to 140°F)

Storage: 12°C to 82°C (10°F to 180°F)

Humidity: 10% to 95%, non condensing

Electrical Specifications

Power: 1.5A @ +5V (±5%) (7.5W) Pertains to 8-channel configuration with a typical load of encoders.

CONFIGURATION AND HARDWARE SETUP

The purchase of the 3U MACRO CPU board provides a 3U-format (100mm x 160mm) board with a DSP processor, MACRO ring circuitry, piggyback connectors onto which stack accessory boards can be mounted, and a backplane connector through which other 3U-format boards can be connected by means of a UBUS passive-backplane board.

The MACRO CPU board went through an extensive redesign in the –105 revision, because key components on the –104 and older revisions became obsolete. Both the older and the newer versions are described in this manual. The only system change required is a slight change in the DIP-switch addressing of Acc-24E2x and Acc-51E backplane axis boards when using the new MACRO CPU boards.

Note:

It is recommended that only the new MACRO CPU boards, which have stronger backplane bus drivers, be used in UMAC pack configurations.

The 3U MACRO-CPU can be purchased in two physical configurations, distinguished by part number prefix:

- 300-602804-10x provides the 3U MACRO-CPU board without a front plate. This configuration is recommended for stack assemblies.
- 3R0-602804-10x provides the 3U MACRO-CPU board with a front plate. This configuration is recommended for UMAC rack assemblies. The top and bottom plates are provided with the Acc-Px rack.

There are a few options available for the MACRO CPU board. One of the Options A or C must be present on a MACRO CPU board to provide the actual MACRO ring interface circuitry; both may be present:

Option A provides an SC-style fiber-optic transceiver to connect into the MACRO ring. Its main component is the U73 transceiver.

Option C provides RJ-45 electrical input and output connectors for the MACRO ring. Its main components are J14 and J17.

Option 10 permits a specified revision of the MACRO Station firmware to be installed in the flash memory in the card. Without this option, the latest released revision is installed. A label on the flash memory IC indicates the firmware revision installed at the factory (but not necessarily which revision is presently installed in the IC). The presently installed revision can be ascertained by using the `MSVER{node #}` command.

Board Hardware Setup

The hardware setup of the 3U MACRO CPU Board consists of the setting of two rotary switches, the setting of several E-point jumpers on each board, followed by power supply and signal connections.

Note:

E-Point Jumper numbers are shown in white ink on the legend of each board. Pin numbers for each number can be determined either from the legend on the component side on the board, or by looking at the solder side of the board, where pin 1 has a square solder pad.

Board Jumper and Switch Setup

The MACRO Station has two 16-way rotary switches on the MACRO CPU board that establish the station's basic configuration on the MACRO ring.

SW1 Rotary Switch Setting: SW1 establishes how many servo nodes, and which servo nodes, will be used on the MACRO station. It also establishes the mapping of MACRO node numbers to MACRO Station channel numbers. This mapping information will be important in establishing the software setup.

The following table shows possible MACRO Station axis configurations and the appropriate settings of SW1:

# of Servo Channels and Nodes Used	Which MACRO Servo Nodes Used	Stack Axis Boards Used	Backplane (UMAC) Axis Boards Used	SW1 Setting
2	0, 1	1x Acc-1E	--	8
2	4, 5	1x Acc-1E	--	9
2	8, 9	1x Acc-1E	--	10 (\$A)
2	12, 13	1x Acc-1E	--	11 (\$B)
2	0, 1	1x Acc-2E*	1x Acc-24E2x or 51E	2
2	4, 5	1x Acc-2E*	1x Acc-24E2x or 51E	3
2	8, 9	1x Acc-2E*	1x Acc-24E2x or 51E	4
2	12, 13	1x Acc-2E*	1x Acc-24E2x or 51E	5
4	0, 1, 4, 5	1x Acc-2E	1x Acc-24E2x with Option 1x or 1x Acc-51E with Option 1	0
4	8, 9, 12, 13	1x Acc-2E	1x Acc-24E2x with Option 1x or 1x Acc-51E with Option 1	1
6	0, 1, 4, 5, 8, 9	1x Acc-1E, 1x Acc-2E	1x Acc-24E2x with Option 1x or 1x Acc-51E with Option 1; Plus 1x Acc-24E2x or 51E	12 (\$C)
6	0, 1, 4, 5, 8, 9	2x Acc-2E*	1x Acc-24E2x with Option 1x or 1x Acc-51E with Option 1; Plus 1x Acc-24E2x or 51E	6
8	0, 1, 4, 5, 8, 9, 12, 13	2x Acc-2E	2x Acc-24E2x with Option 1x / Acc-51E with Option 1	7
More detailed information on the SW1 settings is presented in the Jumper/Switch description in the back of this manual.				

SW2 Rotary Switch Setting: SW2 establishes the number of the master IC to which the MACRO station will respond. The values of 0 to 15 correspond to Master numbers 0 to 15, respectively. For a non-Turbo PMAC2 master, this value must match the master number value in the first hexadecimal digit of PMAC2's I996. For a Turbo PMAC2, this value must match the master number value in the first hexadecimal digit of the Turbo PMAC2's I6840, I6890, I6940, or I6990, for MACRO ICs 0, 1, 2, or 3, respectively, on the Turbo PMAC2. The default switch setting is 0, so the station will respond to Master 0.

Watchdog Timer Enable Jumper: For normal operation of the Compact MACRO Station, jumper E1 should be OFF to enable the watchdog timer (an important safety feature).

Operational Mode Jumper: Jumper E2 should connect pins 2 and 3 to tell the CPU it is in normal operational mode, not in bootstrap mode. It should only connect pins 1 and 2 to load new firmware into the flash IC through the serial port.

Baud Rate Jumper: Jumper E3 must be ON if you are connecting an Acc-8D Option 9 Yaskawa absolute encoder converter to the J7 serial port (most users will connect it to the JTHW port instead). This sets the baud rate to 9600. If E3 is OFF, the baud rate is 38400.

Power Supply Check Jumper: Remove jumper E4 if you are not bringing a +/-12V to +/-15V supply into the Compact MACRO Station itself (5V only). If bringing these analog circuit supplies into the Compact MACRO Station, it is best to have jumper E4 on, so that the servo outputs are disabled if either of the analog supplies is lost.

MACRO Input Select Jumper: Because the MACRO CPU board can potentially accept MACRO ring input from either the RJ-45 electrical input or the fiber input, select which input is used (even if only one of the ring interface options is present). Jumper E40 must be ON to use the fiber input; it must be OFF to use the electrical input. (If both interface options A and C are present, either ring output may be used, regardless of the setting of E40.)

MACRO Signal-Loss Detect Jumper: Jumper E5 (board revisions -105 and newer only) should connect pins 1 and 2 so that the MACRO receiver's (fiber or electrical) loss-of-signal detect is reported automatically as a byte violation error. Older revisions (-104 and before) of the board could not use the receiver's signal-loss detect as a violation error (relying on higher-level detection schemes), and connecting pins 2 and 3 makes operation of the new revision completely compatible with the old. This is not recommended.

Board Connections

The connection of Compact MACRO Station to other stations on the MACRO ring is achieved by connecting the output connector of the Compact MACRO Station to the input connector of the next station and by connecting the output connector of the previous station to the input connector of the Compact MACRO Station. There must be a completely connected ring, with all stations powered up, for any communications to occur on the ring.

Optical Fiber Ring Connection: The U73 integrated fiber optic transceiver is used for both the optical fiber input and the optical fiber output connections to the MACRO ring. With the component side of the board up, and the opening facing you, the input socket is on the right, and the output socket is on the left (these are marked on the component).

RJ45 Electrical Ring Connection: The J14 connector is used for the input from the previous station on the MACRO ring if electrical connection is used, and the J17 connector is used for the output to the next station on the MACRO ring.

Multiplexer Port: The J6 26-pin header is used to connect to multiplexer port accessories such as the Acc-8D Option 7 resolver-to-digital converter board and the Acc-8D Option 9 Yaskawa absolute encoder interface board. This port can be used alternately to provide eight inputs and eight outputs (non-multiplexed) at TTL levels.

Backplane UBUS Expansion Port: The P2 96-pin DIN header is used to connect to expansion port accessories such as the Acc-9E, 10E, 11E, 12E, and 14E I/O boards, or the Acc-24E2x axis boards, through an Acc-Ux UBUS backplane board. It can also be used to bring in 5V power, and optionally +/-15V power, from a backplane or breakout board, to the entire MACRO Station.

Note:

When interfacing to accessory boards across the UBUS backplane, it is strongly recommended to use a new revision (-105 or higher) of the MACRO CPU board, and an Acc-Ux backplane board (not an older Acc-Jx backplane board). The newer revision MACRO CPU boards have stronger bus driver ICs, but they do not work well with the termination of the Acc-Jx backplane boards.

Power Terminal Block: The TB1 4-point terminal block can be used to bring in 5V power, and optionally +/-15V power, to the entire MACRO Station. In a UMAC (pack) configuration, the power is more likely to be brought in through the backplane.

JUMPER AND SWITCH CONFIGURATIONS

Card Layout

The Location columns of the following tables refer to the mapped locations shown in the drawings below:

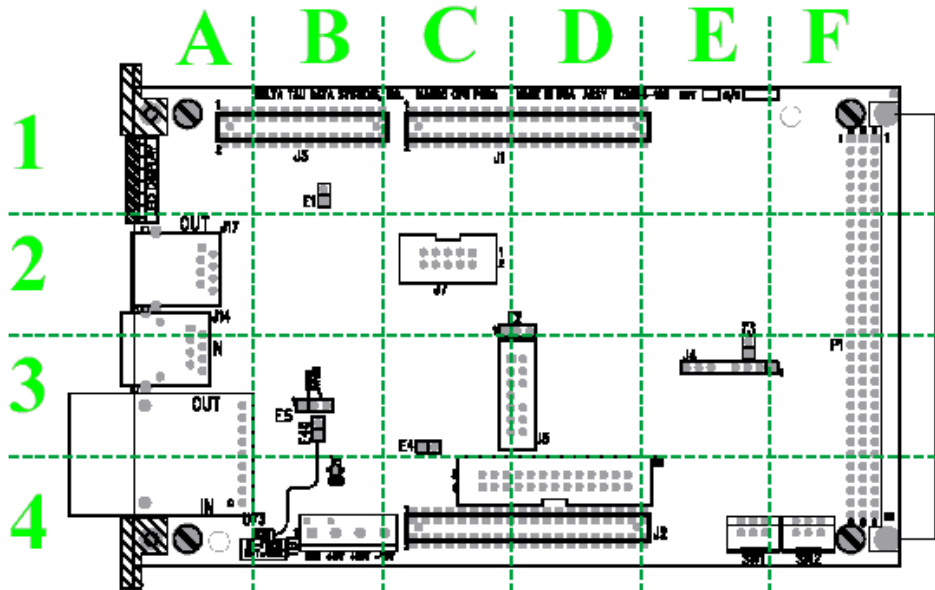

REV-105 and Later Revisions

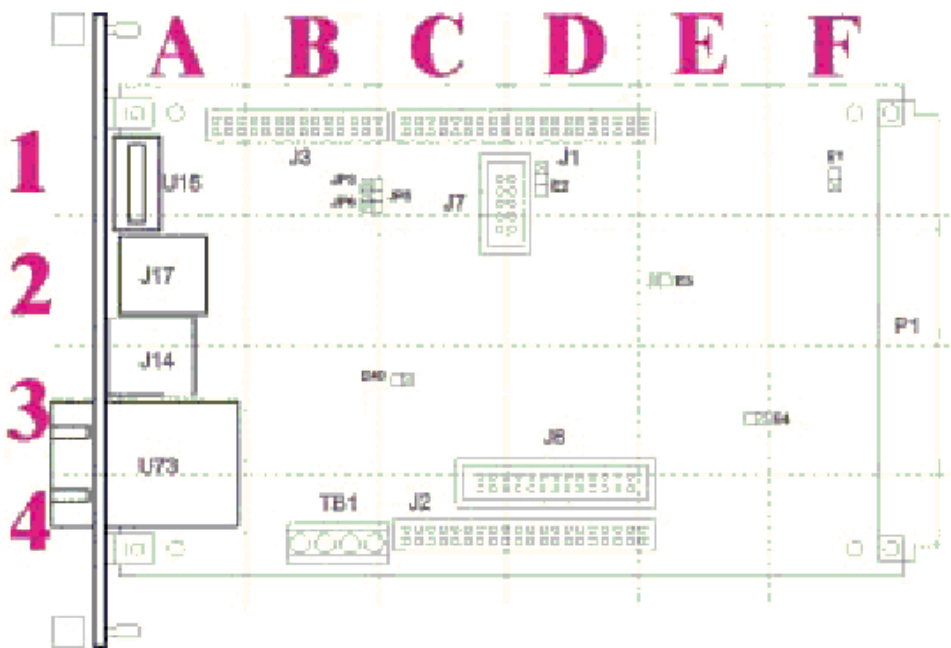

REV-104 and Earlier Revisions

Note:

Pin 1 of an E-point is masked by an X in white ink on the composite side and by a square solder pad on the solder side.

E1: Watchdog Timer Disable

Rev –105 and Later Location	Rev –104 and Earlier Location	Jumper Type	Description	Default
B-1	F-1	2-Pin	Remove jumper to enable Watchdog Timer. Jump pins 1 and 2 to disable Watchdog Timer (for test purposes only).	Not jumpered

E2: CPU Mode Operation

Rev –105 and Later Location	Rev –104 and Earlier Location	Jumper Type	Description	Default
D-2	D-1	3-Pin	Jump pins 1 and 2 for firmware download through serial port. Jump pins 2 and 3 for normal operation.	Pin 2-3

E3: Serial Port Baud Rate

Rev –105 and Later Location	Rev –104 and Earlier Location	Jumper Type	Description	Default
E-3	E-2	2-Pin	Jump pins 1 and 2 for 9600-baud serial port operation. (Required for Yaskawa interface). Remove jumper for 38400-baud serial port operation.	Not jumpered

E4: Power Supply-Loss Control (± 15 Vdc Supply Monitor)

Rev –105 and Later Location	Rev –104 and Earlier Location	Jumper Type	Description	Default
E-3	E-2	2-Pin	Jump pins 1 and 2 to disable servo outputs on loss of +5V, +15V, or –15V power supply. Remove this jumper to monitor +5Vdc power supply only.	Not jumpered
			± 15 V supply monitoring is not usually required for applications without DACs or A-D converters.	

E5: MACRO Received Signal Detect/Bypass Mode (Rev -105 and 106 only)

Does not Exist on Rev 107 and Later Models

Rev –105 and Later Location	Rev –104 and Earlier Location	Jumper Type	Description	Default
B-3		3-Pin	Jump pins 1 and 2 to access the receiver's signal detect operation. Jump pins 2 and 3 to bypass the receiver's signal detect operation. This jumper does not exist on MACRO-CPU versions -104 and earlier.	Pin 1-2

E40: MACRO Input (Fiber/Wired) Selector

Rev –105 and Later Location	Rev –104 and Earlier Location	Jumper Type	Description	Default
B-3	C-3	2-Pin	Remove jumper to select MACRO wired (RJ45) input from J14. Jump pins 1 and 2 to select MACRO fiber optic input from U73.	Jumpered (Option A) Not jumpered (Option C)

JP3: MACRO Loop Back Test Select for Copper only (Rev -104 and Earlier)

Rev –105 and Later Location	Rev –104 and Earlier Location	Jumper Type	Description	Default
	B-1	2-Pin	Remove jumper to select loop back in the copper interface of MACRO communications (for test purposes only). Jump pins 1 and 2 for normal copper MACRO communications. This jumper does not exist on MACRO-CPU versions 105 and greater.	Pin 1-2

JP4: Reserved for Future Use

JP5-JP6: MACRO Copper EQ Select (Rev -104 and Earlier)

Rev –105 and Later Location	Rev –104 and Earlier Location	Jumper Type	Description	Default
	B-1	2-Pin	These jumpers are used to select different modes of equalization when copper-based communications are used. When not jumpered, adaptive equalization is used. JP5 and JP6 are used for manufacturer's testing only. These jumpers do not exist on MACRO-CPU versions - 105 and greater.	Not jumpered

Switch Configurations

SW1: MACRO Slave Node Configure

SW1 Setting	# of Servo Channels and Nodes Used	MACRO Servo Nodes Specified	Station Channel Nos.	Station Channel Starting Addresses
0 (default)	4	0, 1, 4, 5	1, 2, 3, 4	\$C000, \$C008, \$C010, \$C018*
1	4	8, 9, 12, 13	1, 2, 3, 4	\$C000, \$C008, \$C010, \$C018*
2	2	0, 1	1, 2	\$C000, \$C008*
3	2	4, 5	3, 4	\$C010, \$C018*
4	2	8, 9	1, 2	\$C000, \$C008*
5	2	12, 13	3, 4	\$C010, \$C018*
6	6	0, 1, 4, 5, 8, 9	1, 2, 3, 4, 5, 6	\$C000, \$C008, \$C010, \$C018, \$C020, \$C028*
7	8	0, 1, 4, 5, 8, 9, 12, 13	1, 2, 3, 4, 5, 6, 7, 8	\$C000, \$C008, \$C010, \$C018, \$C020, \$C028, \$C030, \$C038*
8	2	0, 1	9, 10	\$C090, \$C098
9	2	4, 5	9, 10	\$C090, \$C098
10	2	8, 9	9, 10	\$C090, \$C098
11	2	12, 13	9, 10	\$C090, \$C098
12	6	0, 1, 4, 5, 8, 9	1, 2, 3, 4, 9, 10	\$C000, \$C008, \$C010, \$C018, \$C090, \$C098
13	0 (I/O only)	None	None	None
14	(Reserved For Future Use)			
15 ***	0	11	-	-

* These addresses are for stack axis boards. Add \$40 to these addresses for backplane axis boards.
 ** Other bits of this I-variable may also be set to enable I/O nodes or other slave stations it is commanding
 *** A setting of 15 forces the station to use its factory default I-variables on power-up/reset.

SW1 Setting	First Axis Board Servo IC	Second Axis Board Servo IC	PMAC2's I996 Value ** (Turbo PMAC2'S I6840, etc.)	PMAC2's I1000, I1002 Value (Turbo PMAC2's I70, I71, etc.)
0 (default)	4-axis	None	\$F8033	\$0033
1	4-axis	None	\$FB300	\$3300
2	4-axis	None	\$F8003	\$0003
3	4-axis	None	\$F8030	\$0030
4	4-axis	None	\$F8300	\$0300
5	4-axis	None	\$FB000	\$3000
6	4-axis	4-axis	\$F8333	\$0333
7	4-axis	4-axis	\$FB333	\$3333
8	2-axis	None	\$F8003	\$0003
9	2-axis	None	\$F8030	\$0030
10	2-axis	None	\$F8300	\$0300
11	2-axis	None	\$FB000	\$3000
12	4-axis	2-axis	\$FB333	\$0333
13	None	None	\$F8000	\$0000
14	(Reserved For Future Use)			
15***	-	-	\$F8800	-

* These addresses are for stack axis boards. Add \$40 to these addresses for backplane axis boards.
 ** Other bits of this I-variable may also be set to enable I/O nodes or other slave stations it is commanding
 *** A setting of 15 forces the station to use its factory default I-variables on power-up/reset.

SW2: MACRO Master Number Select

0: Commanded from Master IC # 0

1: Commanded from Master IC # 1 ...

F: Commanded from Master IC # F (15)

Connector Summary

J1: ~*	JEXP_A: for interboard connection
J2: ~*	JEXP_B: for interboard connection
J3: ~*	JEXP_C: for interboard connection
J4: ~*	JISP: Factory configuration header
J5: ~*	JTAG/OnCE: Factory troubleshoot header
J6:	JTHW: Multiplexer Port Connector
J7:	JRS232: Serial Port Connector
J14, J17:	RJ45: MACRO Copper I/O (OPT C)
P1:	JEXP: Backplane Expansion Port Connector
TB1:	JPWR: 4-Pin Terminal Block
U73:	MACRO Fiber Optic Connector (OPT A)

* Typically, these connectors are not designated as end-user interfaces. The pinouts are not included in this hardware reference manual. Consult the factory if pinout information is needed.

MACRO STATION CHARACTER DISPLAY

The Compact MACRO Station has a single hexadecimal character display on the CPU/Interface Board that provides useful information as to the status of the station. The display can show the following values:

Value	Meaning
(Blank)	Ring not active
0-8	Operation OK; value is # of motors enabled
9	(Reserved for future use)
A	Amplifier fault
B	Ring break fault
C	CPU failure fault
D	Ring data error
E	Loss-of-encoder fault
F	Other failure

Hardware Re-Initialization

MACRO hardware re-initialization to factory defaults is enabled when the SW1 setting is set to 15 or F (hexadecimal) and the power is cycled at the MACRO Station. Possibly the only time to use a hardware re-initialization to factory defaults would be if the MACRO Station always powers up with a watchdog (typically if the ring clock at the Ultralite is different than the ring clock at the MACRO Station). Node 11 will be the only MACRO Station node enabled. Therefore, enable node 11 of the MACRO IC at the Ultralite to communicate to the MACRO Station.

Ultralite Example: Servo nodes 0,1,4,5 enabled at Ultralite (I996=\$0F8033)

1. Enable node 11, I996=\$0F8833.
2. Re-establish communications with MS11, (MIvar) commands.
3. Issue **MS\$\$\$***11** to ensure re-initialization.
4. Issue **MSSAVE11** command to save the factory defaults to the Station.

Turbo Ultralite Example: Servo nodes 0,1,4,5 enabled at Ultralite (I6841=\$0F8033)

1. Enable node 11, I996=\$0F8833.
2. Re-establish communications with MS11,(MIvar) commands.
3. Issue **MS\$\$\$***11** to ensure re-initialization.
4. Issue **MSSAVE11** command to save the factory defaults to the Station.

FIRMWARE UPDATES

Downloading new firmware to the MACRO Station is a simple process once the MACRO board is setup properly. To download new firmware to the MACRO station, the user must have the following items:

- 5V power supply
- 2 jumpers
- DB9 female to 10 pin header (any cable used for PMAC RS232 communications)
- PC at the DOS prompt.
- New firmware and necessary downloading batch files

Make sure to power down the MACRO Station.

- To download the software to the MACRO station, first jumper the following E2 (1-2) and E1 (1-2).
- Wire the 5V power to the appropriate terminal on the MACRO station or plug into 3U Rack.
- Place the 10-pin header cable to the serial connection on the MACRO-station and place the other end to the COM1 port on the PC (the batch files were written for COM1 but could be modified if necessary).

- Go to the DOS prompt and create a directory called firmware and station (as an example).

```
C:\firmware\station
```

```
a:\copy *.* c:\firmware\station
```

Go back to the c drive and type the following command

```
c:\firmware\station\mcdwnld
```

The firmware will be down loaded to the MACRO station.

The PMAC Executive Software will soon have the capability of downloading the MACRO Station firmware in the Windows Operating Environment.

Place jumper E2 back to pins 2-3 and remove E1 jumper

Call the factory if you have any questions.

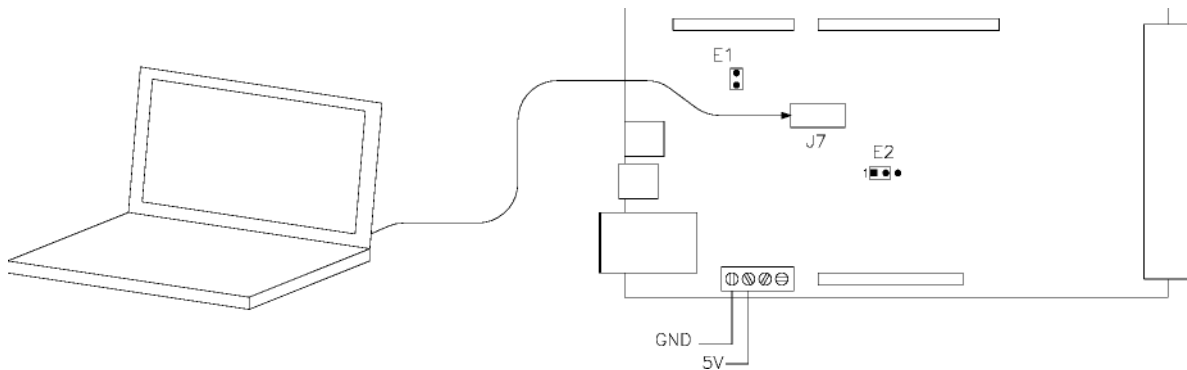

CONNECTOR PINOUTS

The schematic circuits shown in this section are for interface reference only. Subtle differences may exist between the circuits shown here and the actual hardware used.

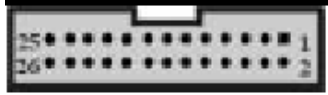
J6: (JTHW) Multiplexer Port Connector				
(26-pin head at Location D-3)				
Pin #	Symbol	Function	Description	Notes
1	GND	Common	PMAC Common	
2	GND	Common	PMAC Common	
3	DAT0	In/Out	Data Byte Bit 0	Must be in for MUX
4	SEL0	In/Out	Select Byte Bit 0	Must be out for MUX
5	DAT1	In/Out	Data Byte Bit 1	Must be in for MUX
6	SEL1	In/Out	Select Byte Bit 1	Must be out for MUX
7	DAT2	In/Out	Data Byte Bit 2	Must be in for MUX
8	SEL2	In/Out	Select Byte Bit 2	Must be out for MUX
9	DAT3	In/Out	Data Byte Bit 3	Must be in for MUX
10	SEL3	In/Out	Select Byte Bit 3	Must be out for MUX
11	DAT4	In/Out	Data Byte Bit 4	Must be in for MUX
12	SEL4	In/Out	Select Byte Bit 4	Must be out for MUX
13	DAT5	In/Out	Data Byte Bit 5	Must be in for MUX
14	SEL5	In/Out	Select Byte Bit 5	Must be out for MUX
15	DAT6	In/Out	Data Byte Bit 6	Must be in for MUX
16	SEL6	In/Out	Select Byte Bit 6	Must be out for MUX
17	DAT7	In/Out	Data Byte Bit 7	Must be in for MUX
18	SEL7	In/Out	Select Byte Bit 7	Must be out for MUX
19	N.C.	N.C	No Connection	
20	GND	Common	PMAC Common	
21	BRLD/	Output	Buffer Request	Low is Buffer Request
22	GND	Common	PMAC Common	
23	IPLD/	Output	In Position	Low is In Position
24	GND	Common	PMAC Common	
25	+5V	Output	+5VDC Supply	Power supply out
26	INIT/	Input	PMAC Reset	Low is Reset

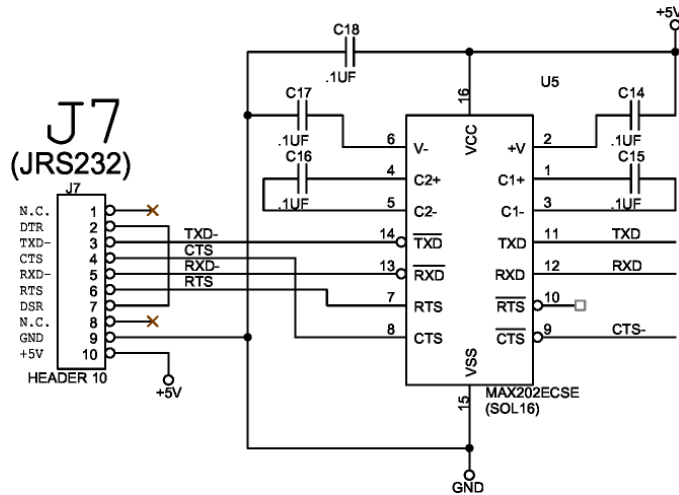

Circuitry for J7- JRS232 Interface

J14, J17: MACRO Copper I/O (Opt C)

(8 pin RJ45)

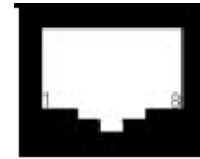

Front View

Pin #	Symbol	Function	Description	Notes
1	DATA+	Data +	Differential MACRO Signal.	J17: DATA+ input. J14: DATA+ output.
2	DATA-	Data -	Differential MACRO Signal	J17: DATA- input. J14: DATA- output.
3	Unused		Unused terminated pin	See schematic below.
4	Unused		Unused terminated pin	See schematic below.
5	Unused		Unused terminated pin	See schematic below.
6	Unused		Unused terminated pin	See schematic below.
7	Unused		Unused terminated pin	See schematic below.
8	Unused		Unused terminated pin	See schematic below.

The cable used for MACRO wired connections is CAT5 verified straight-through 8 conductor.

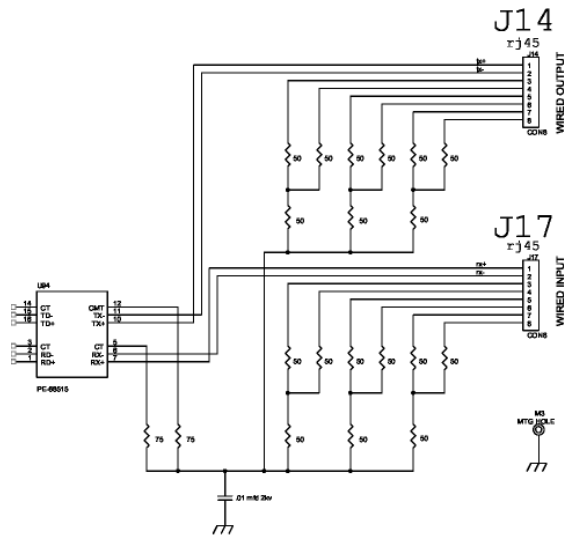

Circuitry for J14 and J17- Copper MACRO I/O

P1: UBUS Interface Connector			
(96 pin EURO-Connector at F-1, 2, 3, 4)			
			<p>Front View on MACRO-CPU Card</p>
Pin #	Row A	Row B	Row C
1	+5Vdc	+5Vdc	+5Vdc
2	GND	GND	GND
3	BD01	DAT0	BD00
4	BD03	SEL0	BD02
5	BD05	DAT1	BD04
6	BD07	SEL1	BD06
7	BD09	DAT2	BD08
8	BD11	SEL2	BD10
9	BD13	DAT3	BD12
10	BD15	SEL3	BD14
11	BD17	DAT4	BD16
12	BD19	SEL4	BD18
13	BD21	DAT5	BD20
14	BD23	SEL5	BD22
15	BS1 (GND)	DAT6	BS0 (GND)
16	BA01	SEL6	BA00
17	BA03	DAT7	BA02
18	BX/Y	SEL7	BA04 (n.c.)
19	CS3-	BA06 (n.c.)	CS2
20	BA05 (CS7-)	BA07 (n.c.)	CS4- (CS6-)
21	CS12-	BA08 (n.c.)	CS10
22	CS16-	BA09 (n.c.)	CS14
23	BA13 (n.c.)	BA10 (n.c.)	BA12 (n.c.)
24	BRD-	BA11 (n.c.)	BWR
25	BS3 (GND)	MEMCS0- (n.c.)	BS2 (GND)
26	n.c.	MEMCS1- (n.c.)	RESET
27	PHASE+	n.c.	SERVO+
28	PHASE- (n.c.)	n.c.	SERVO- (n.c.)
29	GND	n.c.	GND
30	-15Vdc	PWRGUD (n.c.)	+15Vdc
31	GND	GND	GND
32	+5Vdc	+5Vdc	+5Vdc

1. Refer to the UBUS Specification for detailed signal descriptions. This interface is not VME bus compatible.
 2. Items shown in parentheses represent pin descriptions for -104 and earlier revision MACRO-CPU boards.

TB1: (JPWR) 4-Pin Terminal Block				
(Location B-4)				
Pin #	Symbol	Function	Description	Notes
1	GND	Common	Reference Voltage	
2	+5V	Input	Positive Supply Voltage	Supplies all PMAC digital circuits
3	+15V	Input	Positive Supply Voltage	+12V to +15V; used for on-board analog
4	-15V	Input	Negative Supply Voltage	-12 to -15V; used for on-board analog

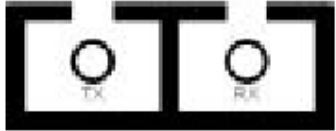
U73: MACRO Fiber Optic Connector (Option A) (2 Socket SC-Style)				 <p style="text-align: center;">Front View</p>
Pin #	Symbol	Function	Description	Notes
1	RX	Fiber Input	MACRO Ring Receiver	
2	TX	Fiber Output	MACRO Ring Transmitter	
A. The fiber optic version of MACRO uses 62.5/125 multi-mode glass fiber optic cable terminated in an SC-style connector. The optical wavelength is 1,300nm. B. It is possible to adapt wire to fiber operation when using OPT A & C on the same MACRO-CPU board.				

HARDWARE MEMORY MAP

The values in this table represent the hardware locations associated with register-based transactions that occur in the 3U MACRO-CPU.

Reference	ADDR (hex)	Description
CS00-	\$FFC0	Stack I/O select #1
CS02-	\$FFC8	Stack I/O select #2
CS04-	\$FFD0	Stack I/O select #3
CS06-	\$FFD8	Stack I/O select #4
CS0-	\$C000	Stack axis 1-4 select
CS1-	\$C020	Stack axis 5-8 select
CS2-	\$C040	UBUS backplane axis 1-8 select
CS3-	\$C060	UBUS backplane axis 5-8 select
CS4-	\$C080	On-board DSPGATE2 select
CS4X-	\$C0C0	UBUS backplane MACRO gate or DSPgate2 select (CS4- on UBUS)
CS10-	\$FFE0	UBUS backplane I/O select #1
CS12-	\$FFE8	UBUS backplane I/O select #2
CS14-	\$FFF0	UBUS backplane I/O select #3
CS16-	\$FFF8	UBUS backplane I/O select #4
MEMCS0-	\$D000	UBUS hardware I/O field (was DPRCS-)
MEMCS1-	\$E000	UBUS hardware I/O field (was VMECS-)

The addressing field size is 16-bits in the 3U MACRO-CPU. The address table above is similar to the PMAC2 product line.

ACCESSORIES

Both the Turbo and the MACRO CPU boards can support either the Stack or the UMAC configuration. The systems are configured modularly with the selection of a series of accessory boards, some appropriate for the Stack, and some appropriate for the UMAC. These accessories are listed here. Each has its own manual for detailed description.

The following table shows 3U products by function:

MACRO CPU Board Options	Board must be ordered with either Option A or Option C.	Option A, fiber-optic connectors	Option C, RJ-45 electrical MACRO connectors
Stack Piggyback Accessory Boards	Acc-1E, 2-Axis Interface Stack Board (UMAC MACRO only), 3x0-602810-10x	Acc-2E, 4-Axis Interface Stack Board, 3x0-602805-10x	Acc-3E, 48/96/144 TTL I/O Stack Board, 3x0-602811-10x
	Acc-4E, Isolated 24-In/24-Out Stack Board, 3x0-602872-10x	Acc-6E, 8/16-Channel 12-Bit ADC Stack Board, 3x0-602810-10x	
UMAC Backplane-Mountable Accessory Boards –Axis	Acc-24E2, 2-Axis Digital PWM, 3x0-603397-10x	Option 1D, Additional 2-Axis Digital PWM, 3D1-603397-10x	Acc-24E2A, 2-Axis Analog, 3x0-603398-10x
	Option 1A, Additional 2-Axis Analog, 3A1-603398-10x	Acc-24E2S, 4-Axis Stepper, 3x0-603441-10x	
UMAC Backplane-Mountable Accessory Boards –I/O	Acc-3E1, 48/96/144 I/O, 3x0-603359-10x	Acc-9E, 48 In, 3x0-603283-10x	Acc-10E, Isolated 48-Output Board, 3x0-603299-10x
	Acc-11E, Isolated 24-In/24-Out Board, 3x0-603307-10x	Acc-12E, Isolated 24-In/24-Hi-Power-Out Board, 3x0-603277-10x	Acc-14E, 48 I/O, 3x0-603472-10x
UMAC Backplane-Mountable Accessory Boards – Communication	Acc-55E, (UNET) Universal Field Bus Adapter Network Card, 3x0-603485-10x		
UMAC Backplane-Mountable Accessory Boards – Miscellaneous	Acc-28E, 16-Bit A/D, 3x0-603404-10x	Acc-36E, A/D, D/A Converter, 3x0-603483-10x	Acc-51E, X 4096 Interpolator, 3x0-603438-10x
	Acc-53E, SSI, 3x0-603360-10x	Acc-56E, Extender Card, 300-603401-10x	Acc-57E, Yaskawa or Mitsubishi ABS, Encoder Unit, 3x0-603484-10x
	Acc-58E, R/D Converter, 16 Bit, 3x0-603482-10x		
UBUS Backplane Boards	Acc-U4, UBUS 4-Slot Backplane, 300-603462	Acc-U6, UBUS 6-Slot Backplane, 300-603403-10x	Acc-U8, UBUS 8-Slot Backplane, 300-603463-10x
	Acc-U10, UBUS 10-Slot Backplane, 300-603464-10x	Acc-U12, UBUS 12-Slot Backplane, 300-603465-10x	Acc-U14, UBUS 14-Slot Backplane, 300-603466-10x
	Acc-U16, UBUS 16-Slot Backplane, 300-603471-10x	Acc-U18, UBUS 18-Slot Backplane, 300-603491-10x	

Amplifiers – Analog ±10VDC Input (Brush Motors)	4-Axis Analog ± 10V Input Linear Amplifier, 24VDC, 0.5/1A, 300-603489-10x	4-Axis Analog ± 10V Input PWM Amplifier, 48VDC, 2/4A, 300-603443-10x	4-Axis Analog ± 10V Input PWM Amplifier, 70VDC, 8/12A, 300-603486-10x
	Backplane, Double Analog Amplifier, 300-603470-10x	Backplane, Single Analog Amplifier, 300-603490-10x	
Amplifiers – Digital PWM Input (brushless)	2-Axis Digital PWM Amplifier, 360VDC, 4/8A, 400-603391-10x	2-Axis Digital PWM/Macro Amplifier, 360VDC, 8/16A, 400-603392-10x	Single Axis Digital PWM/Macro Amplifier, 360VDC, 8/16A, 401-603391-10x
	Single-Axis Digital PWM Amplifier, 360VDC, 8/16A, 401-603492-10x	Power Supply for 3U Digital PWM Amplifiers, 400-603428-10x	Backplane, Digital PWM, 300-603435-10x
Power Supplies – DC Input	Acc-F, 3U DC to DC Converter, 10A, 30F-603216-OPT		
Power Supplies – AC Input	Acc-E, 3U AC Power Supply, 8A, 30E-603269-OPT	Acc-E1, 3U AC Power Supply, 14A, 31E-603269-OPT	Acc-E2, AC Power Supply, 20A, 32E-603468-OPT
UMAC Chassis Assemblies (Rack)	3U Rack, 10-1/2 Slot (42T) 542-602932-10x	3U Rack, 15-3/4 Slot (63T) 563-602932-10x	3U Rack, 21 Slot (84T) 584-602932-10x
	3U Rack, Variable Width per Customer Requirements (custom design) , 500-602932-		
Hybrid Stack/Pack Accessories (Legacy Systems Only)	Acc-8DE, 2-Axis 3U Analog-Output Breakout Board, 3x0-603215-10x	Acc-8FE, 2-Axis 3U Digital-Output Breakout Board, 3x0-603176-10x	Acc-13, Encoder Terminal Block Board, 300-603365-10x
	ACC13A, Flag Terminal Block Board, 300-603366-10x	Acc-13B, Amplifier Terminal Block Board, 300-603367-10x	Acc-15E, Isolated 12-In/12-Out Opto22 Driver & Breakout Board, 300-603488-