



AB1A-3U Driver User Manual

March 2004

For Further Information Contact

Heason Technologies Group Ltd

Tel: +44(0)1403 755800

Fax: +44(0)1403 755810

Email: sales@heason.com

Freephone 0800 374903 www.heason.com

Heason
Technologies Group

P/N: AB3U-458-000-C

Nanomotion Ltd. POB 223, Yokneam 20692, Israel

Tel: 972-4-959-0862 Fax: 972-4959-0995

Web Site: www.nanomotion.net

E-mail: nano@nanomotion.com

Copyright

This document contains proprietary information of Nanomotion Ltd., and Nanomotion Inc., and may not be reproduced in any form without prior written consent from Nanomotion Ltd. and Nanomotion Inc.

No part of this document may be reproduced, translated, stored in a retrieval system or transmitted in any form and by any means, electronic, mechanical, photographic, photocopying, recording, or otherwise, without the written permission of Nanomotion Ltd.

Information provided in this document is subject to change without notice and does not represent a commitment on the part of Nanomotion Ltd.

Copyright March 2003, Yokneam, Israel. All rights reserved.

All products and company names are trademarks or registered trademarks of their respective holders.

Limited Warranty

Nanomotion Ltd. (hereinafter NM) warrants the product (other than software) manufactured by it to be free from defects in material and workmanship for a period of time of one year (except those parts normally considered as consumable/expendable components such as motor conditioning brushes). The warranty commences thirty (30) days from the date of shipment.

NM warrants those parts replaced under warranty for a period equal to the remaining warranty coverage of the original part.

NM's sole and exclusive obligation under this warranty provision shall be to repair, or at its sole option exchange defective products or the relevant part or component, but only if: (i) the Purchaser reports the defect to NM in writing and provides a description of the defective product and complete information about the manner of its discovery within ten (10) days of its discovery; (ii) NM has the opportunity to investigate the reported defect and determines that the defect arises from faulty material, parts or workmanship; and (iii) the Purchaser returns the affected product to a location designated by NM. These provisions constitute the exclusive remedy of the Purchaser for product defects or any other claim of liability in connection with the purchase or use of NM products.

This warranty policy applies only to NM products purchased directly from NM or from an authorized NM distributor or representative.

This warranty shall not apply to (i) products repaired or altered by anyone other than those authorized by NM; (ii) products subjected to negligence, accidents or damage by circumstances beyond NM control; (iii) product subjected to improper operation or maintenance (i.e. operation not in accordance with NM Installation Manuals and/or instructions) or for use other than the original purpose for which the product was designed to be used.

NM shall not in any event have obligations or liabilities to the Purchaser or any other party for loss of profits, loss of use or incidental, increased cost of operation or delays in operation, special or consequential damages, whether based on contract, tort (including negligence), strict liability, or any other theory or form of action, even if NM has been advised of the possibility thereof, arising out of or in connection with the manufacture, sale, delivery, use, repair or performance of the NM products. Without limiting the generality of the preceding sentence, NM shall not be liable to the Purchaser for personal injury or property damages.

CE Compliance

This product has been tested for Electric Safety and Electromagnetic Compatibility inside a closed shielded metal cabinet and was found to be in compliance with the following directives and standards:

EMC Directive 89/336/EEC

FCC 47 CFR part 15 subpart B.

LVD directive 73/23/EC, Article 5

EN 61800-3:1996 + A11: 2000 for second environment

EN 61000-3-2:2000, EN 61000-3-3:1995 + A1: 2001

FCC 47 CFR: 2002 part 15, subpart B, class A

EN 61010-1:2001

Table of Contents

1 AB1A-3U DESCRIPTION	1
1.1 General	1
1.2 Main Features	1
1.3 Operating Principles	1
1.4 Operation Modes	3
1.4.1 Velocity Mode Operation.....	3
1.4.2 Step Mode Operation	4
1.4.2.1 Enabling the Step Mode	4
1.4.3 Gate Mode Operation.....	4
1.4.3.1 Enabling the Gate Mode.....	4
1.5 Using the AB1A-3U to Drive LS Motors	5
2 CONNECTIONS AND I/O SETTINGS	6
2.1 Motion Controller Connection.....	6
2.2 Cable Connections	7
2.2.1 Shielding.....	7
2.3 Motor Connections.....	7
2.3.1 Motor Cable Length.....	8
2.4 Opto-isolated Inputs.....	9
2.4.1 Voltage Source Configuration	9
2.5 Fault Output	10
2.6 LED Indicators	10
2.7 Before Operating the Motor	11
3 SPECIFICATIONS	12
3.1 Parameters and Conditions	12
3.2 AB1A-3U Layout	13
3.3 AB1A-3U Pin Arrangement.....	14

List of Figures

Figure 1: AB1A-3U Block Diagram	2
Figure 2: Schematic Diagram of the Output Stage with an Internal LC Card	3
Figure 3: Differential Analog Input Connection.....	6
Figure 4: Non-Differential (single ended) Analog Input Connection.	7
Figure 5: J1 Connection to a Motor or Branch Cable	8
Figure 6: Jumper 2 Configuration	9
Figure 7: Opto-Isolated Input Interface	10
Figure 8: LED Indicators	11
Figure 9: AB1A-3U Layout	13

List of Tables

Table 1: AB1A-3U Power Consumption	12
Table 2: Electrical Specifications	12
Table 3: Environmental Conditions.....	12
Table 4: Analog Input Specifications	13
Table 5: Dissipated Heat.....	13
Table 6: Input/Output Connector Pin Out	14

List of Abbreviations

A	Ampere
AC	Alternating Current
DC	Direct Current
LC	Coil Capacitor Resonance Circuit
LED	Light Emitting Diode
mA	Milliampere
mW	Milliwatt
TTL	Transistor-Transistor Logic
Vrms	Volts Root Mean Square

HIGH VOLTAGE ON CARD.



ATTENTION:

***OPERATE ONLY INSIDE A CLOSED, SHIELDED METAL
CABINET.***

1 AB1A-3U Description

1.1 General

The AB1A-3U is a single-axis motor driver designed to drive up to 32 motor elements in parallel. The motor types that can be driven by AB1A-3U are HR, LS, ST and STM.

1.2 Main Features

- High precision (11 bits) control of the power output stage
- Drives up to 32 Nanomotion motor elements in parallel
- Interfaces with an Analog command
- Discrete inputs enable feedback from external sources, such as limit switches, emergency stop command, etc.
- LED indicators
- Output short circuit protection
- Reduced sensitivity to cable length and capacity

1.3 Operating Principles

The AB1A-3U Driver comprises the AB1A-3U main card and an LC card. The AB1A-3U Card converts the analog input command signal into a corresponding PWM square wave output signal that is fed to the LC Card. The LC Card produces the sine wave output voltage that drives the motor.

The LC Card type and configuration depends on the number of motor elements driven.

- For 1 to 16 elements, the LC circuit is internal to the AB1A-3U
- For 32 elements, the LC circuit is external to the AB1A-3U (LC Box)

An internal DC-to-DC converter that is fed from an external +48V power supply supplies the required DC voltages.

Figure 1 illustrates a typical application of the AB1A-3U Driver.

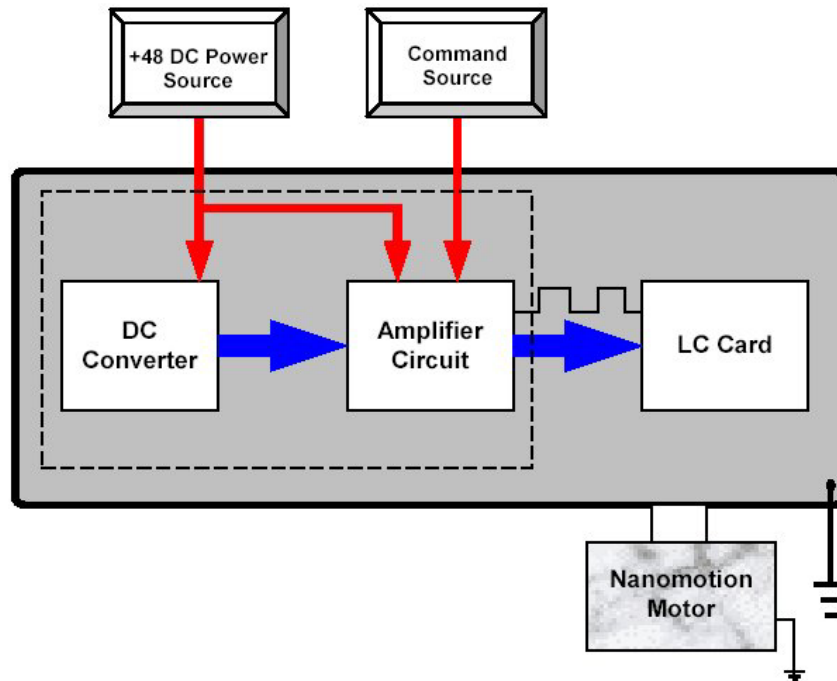

Figure 1: AB1A-3U Block Diagram

The motor has three terminals: "UP" (red wire), "DOWN" (white wire) and "COMMON" (black wire). The voltage applied between the "UP" and the "COMMON" terminals causes the motor to move in one direction, while voltage applied between the "DOWN" and the "COMMON" terminals causes the motor to move in the opposite direction.

Figure 2 is a schematic drawing of the power output.

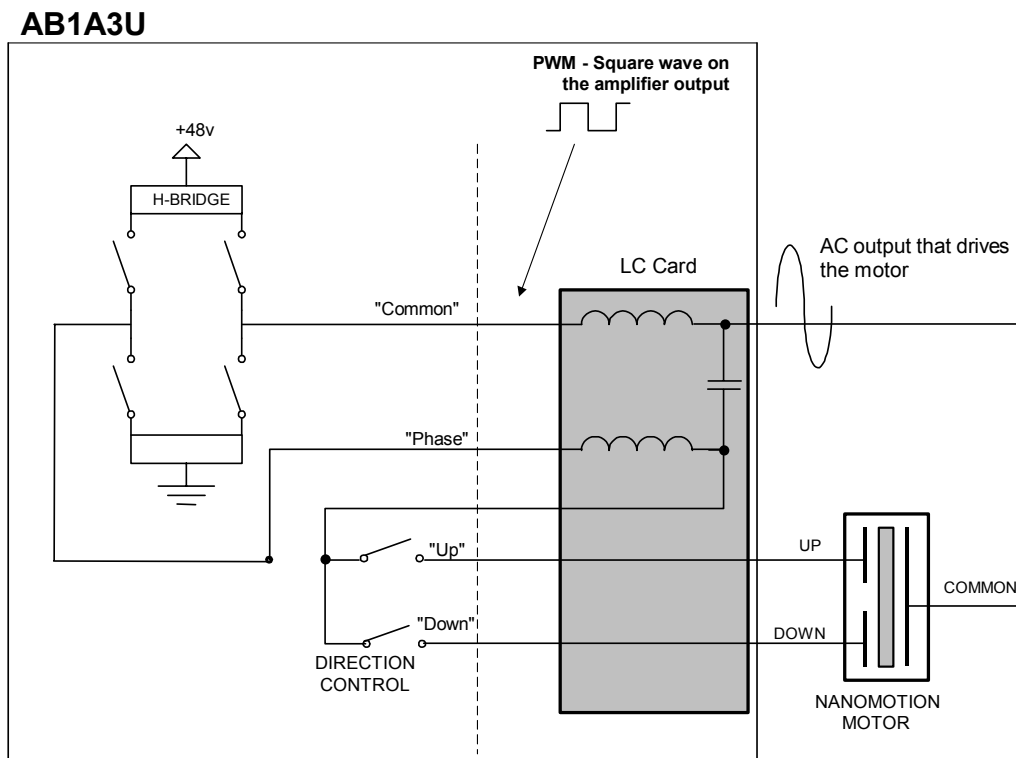

Figure 2: Schematic Diagram of the Output Stage with an Internal LC Card

1.4 Operation Modes

The AB1A-3U can be operated in one of the following operation modes:

- **Velocity Mode**, in which the motor is driven continuously.
- **Gate Mode**, in which the motor is driven at low velocity by turning the driver output ON and OFF in time intervals defined by outside TTL signal in an open loop.
- **Step Mode**, in which the driver output is turned OFF and ON at predefined intervals, in order to drive the motor in discrete steps.

1.4.1 Velocity Mode Operation

In this operation mode, the motor is driven continuously by applying the analog command voltage (± 10 V) using a relevant interface device (joystick or motion controller).

1.4.2 Step Mode Operation

In this operation mode the motor is turned on and off for fixed time intervals defined in the hardware as follows:

- ON phase - 1/16 second
- OFF phase - 0.5 second

The amplitude of the output corresponds to the analog input value and thus determines the speed of the motor.

1.4.2.1 Enabling the Step Mode

In order to enable the Step Mode, the B10 pin (see Table 6) should be shorted to the ground. By default, neither B10 nor Z14 (see section 1.4.3.1) is shorted to the ground, so that the user can select the required connection.

1.4.3 Gate Mode Operation

In this operation mode the motor is driven in open loop at low velocities by turning the driver output ON and OFF in time intervals defined by an external switching.

The amplitude of the output corresponds to the analog input value and thus determines the speed of the motor.

In Gate Mode, as opposed to Step Mode, the pulse width and pulse frequency are user-defined.

The allowable parameter values for the external signal are as follows:

- Voltage level: 0V(on); 5V(off). Open collector logic is also an option.
- Minimum pulse width: 50 μ sec
- Maximum pulse frequency: 1 kHz

1.4.3.1 Enabling the Gate Mode

In order to enable the Gate Mode, the Z14 pin (see Table 6) should be shorted to the ground. Verify that the B10 pin is not shorted to the ground at the same time.

Once Z14 is shorted to the ground, the driver is in Gate Mode. Conduct now the external switching signal through pin B10 (see also section 1.4.2.1).

1.5 Using the AB1A-3U to Drive LS Motors

Under normal conditions, the LS series of motors should not be operated with command voltage exceeding 3.5V. To allow some margin in cases, which require momentarily use of higher power, the AB1A-3U for the LS series of motors is limited to 5V.

Nanomotion expects that during normal operation, the commanding controller should protect the motor, and assumes that in continuous operation the command will not exceed 3.5V. The protection scheme is as follows: the torque limit at the controller must be set to half of the maximum command voltage (5V), and be limited to 5 seconds. The controller RMS torque limit must be set to 35% of the full command.

2 Connections and I/O Settings

2.1 Motion Controller Connection

There are two options of connecting a motion controller to the AB1A-3U driver:

- Differential connection (see Figure 3)
- Single-Ended Connection (see Figure 4)

The differential connection enhances noise immunity.

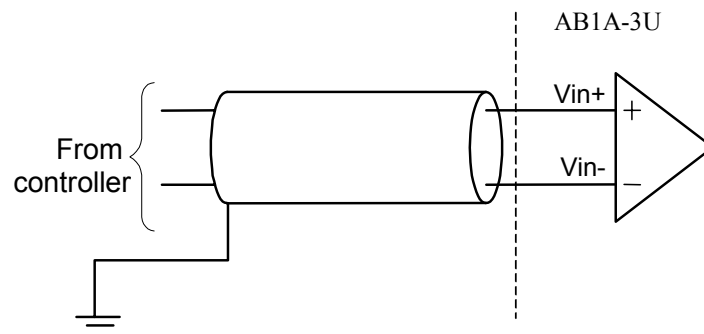

Figure 3: Differential Analog Input Connection

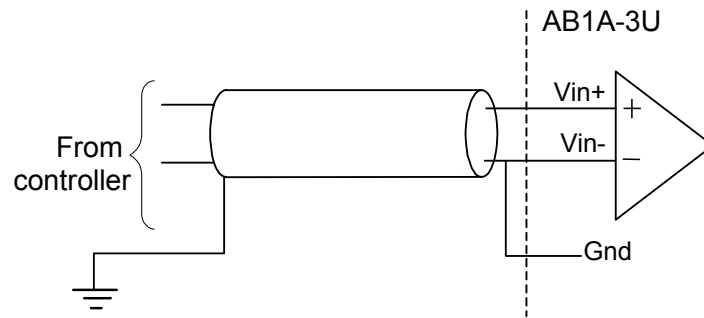

Figure 4: Non-Differential (single ended) Analog Input Connection.

2.2 Cable Connections

Connect the following groups of cables together, isolating each of the signals:

- POWER SUPPLIES – use 22 AWG (or lower AWG) wires for the power supplies. For noisy surroundings, it is recommended to twist the ground line and the power line together.
- ANALOG COMMAND – a twisted shielded cable is recommended.
- DISCRETE INPUTS – These signals are not sensitive to noise and can be grouped together in the same harness with any of the other groups.

2.2.1 Shielding

As the high motor voltage is induced on the cable shield, it is required to ground the shield on both motor and driver sides to the infrastructure earth.

2.3 Motor Connections

The “Motor Disconnect” signal is available only at the motor (or branch cable) connector, where it is shorted to ground. This ensures that unprotected motor pins will not be exposed to high voltage when the motor is not connected.

If more than one motor is connected to the AB1A-3U Driver Box, use a suitable branch cable or extension cable, as supplied by Nanomotion.

If the motor type or the number of motor elements is changed, consult Nanomotion for the appropriate LC Card configuration and other driver configuration changes that may be required.

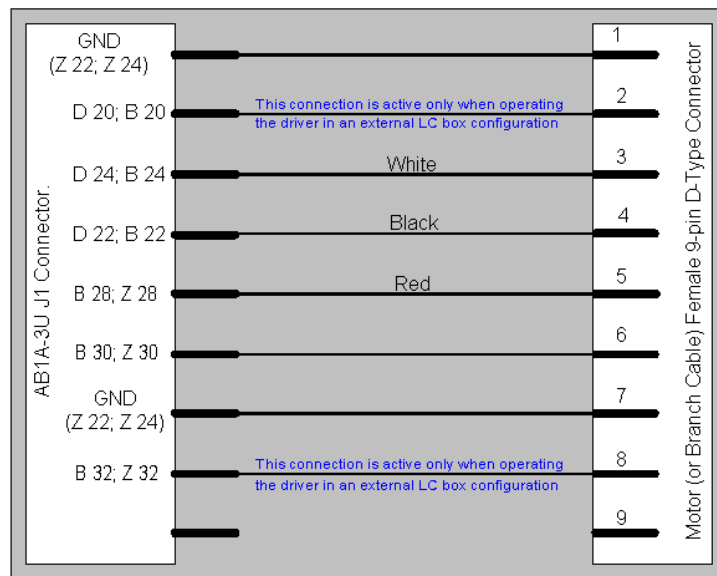

Figure 5: J1 Connection to a Motor or Branch Cable

2.3.1 Motor Cable Length

The overall length of the cables that connect the AB1A-3U driver to the motor elements should be in accordance with the following:

- Up to 2 motor elements – 5m
- 4 – 32 motor elements – 10m



NOTE:

Use Nanomotion standard cables. Branching is possible to 2 and 4 identical motors. Branch cables must be of identical length, the sum of which not exceeding the allowed total cable length.



NOTE:

Nanomotion can guarantee proper driver and motor performance only when Nanomotion standard cables are used.

2.4 Opto-isolated Inputs

The following inputs are opto-isolated and are activated by shorting them to ground (see also Table 6):

- Powering Up/Down
 - ◆ Motor Connected: Safety input. The motor operation is enabled only when this input is shorted to the ground.
 - ◆ Enable: Enables the motor activation
 - ◆ Emergency Stop (ES): Disables the AB1A-3U output
- Mode Enabling
 - ◆ Step Mode: Enables Step Mode operation
- Direction Restrictions
 - ◆ Left Switch: Disables motor motion to the left
 - ◆ Right Switch: Disables motor motion to the right

2.4.1 Voltage Source Configuration

The opto-isolated input signals are activated as short-to-ground. The voltage for the opto-isolated circuit (see Figure 7) is provided by either the internal +5V supply (default setting) or an external voltage supply via pin 20 on the I/O Port connector. The input to be activated should be shorted to external voltage supply ground.

Configure jumper JP 2 (located near LC card) on the AB1A-3U card according to the voltage source:

- Pin 1 shorted to Pin 2, for an internal +5V source (factory setting)
- Pin 2 shorted to Pin 3, for an external voltage source



ATTENTION:

Do not short Pin 1 to Pin 3 on JP2. Doing so shorts the external power supply to the +5V supply! The input circuit is limited to sink up to 10 mA but not less than 3 mA.

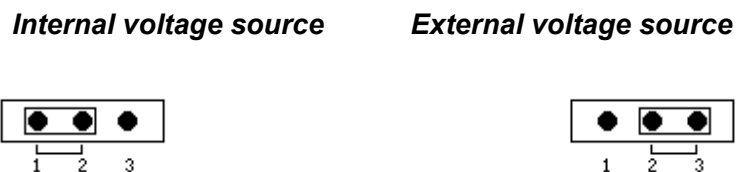

Figure 6: Jumper 2 Configuration

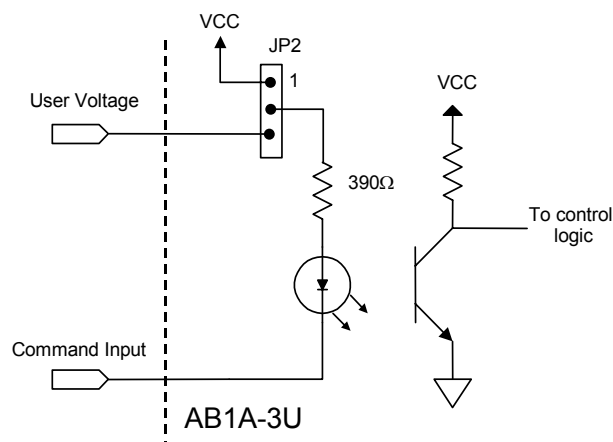

Figure 7: Opto-Isolated Input Interface

2.5 Fault Output

Fault: An open collector logic output that is active shorted to ground under the following conditions:

- Over Current
- The motor is not connected and the “Motor Disconnect” signal is floating
- Emergency Stop



NOTE:

The Fault output is capable of sinking a maximum of 20 mA, and is not protected from over current.

2.6 LED Indicators

There are five LED indicators located on the front side of the card. See Figure 8 for LEDs' locations.

- **Power ON.** Green LED. Lights when 48V is applied
- **Fault.** Red LED. Lights when over current protection is triggered.
- **Motor Disabled.** Red LED. Lights when motor is connected and the driver is disabled.
- **Motor Not Connected (NC).** Red LED. Lights when motor is not connected.
- **Motor Enabled.** Green LED. Lights when drive is enabled.

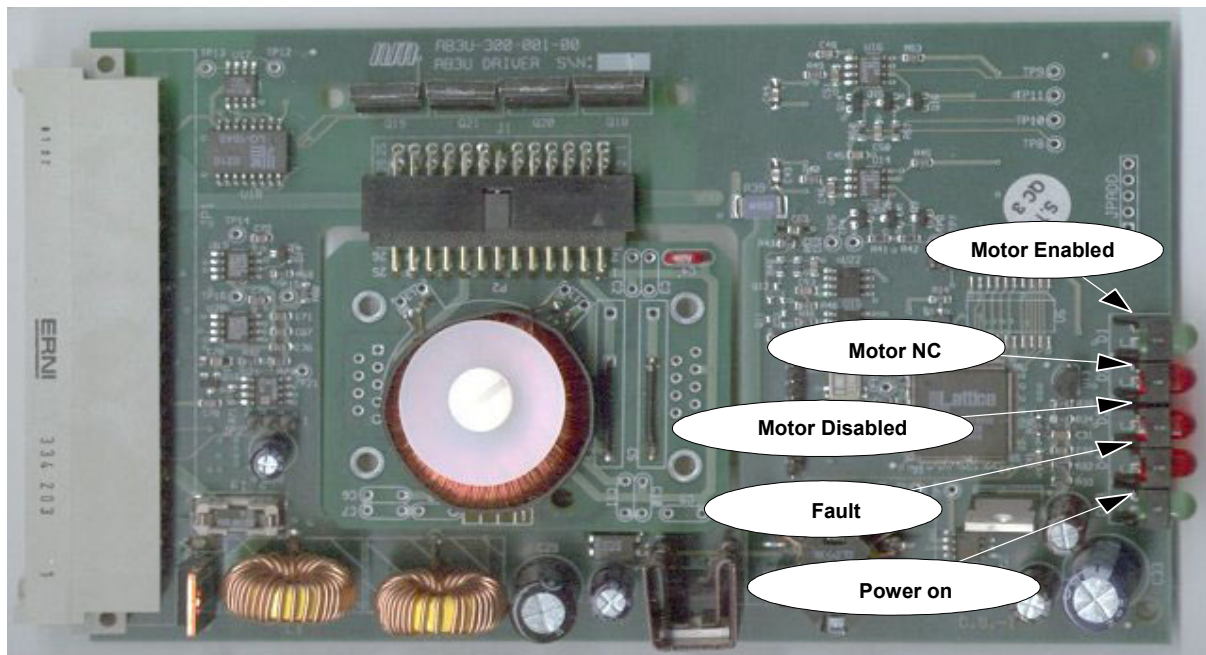

Figure 8: LED Indicators

2.7 Before Operating the Motor

Before operating the AB1A-3U, verify the following:

- Card configuration (as specified on card) matches the motor to be operated,
- Jumper JP2 is set to the required mode of operation.
- The external power supply is capable of supplying the required power consumption of the AB1A-3U.
- There is no command when switching the power to “ON”.
- Make sure that all motors that are to be driven by the AB1A-3U are preloaded.



ATTENTION:

The command should be limited according to the envelope of performance of the motor. Refer to the Motor User Manual.

3 Specifications

3.1 Parameters and Conditions

Table 1: AB1A-3U Power Consumption

Power Input	+48VDC \pm 5% (stabilized)
Max Motor Output	250-290 Vrms
Power Consumption without Load	+48VDC/0.125A
Power Consumption with Max load	+48VDC/6.5A max

Table 2: Electrical Specifications

Supply Voltage	Current Consumption	Used When
+48v \pm 5%	\leq 200 mA	1x HR1 is connected.
	\leq 500 mA	1x HR2 is connected.
	\leq 800 mA	1x HR4 is connected.
	\leq 1200 mA	1x HR8 is connected.

The required power supply value should be calculated by adding the total power consumption of all the motors that are connected to the AB1A-3U power consumption without motor (+48VDC/125 mA_{rms}) according to the following:

- $I = 125\text{mA} + n \cdot (\text{current consumption of a single motor})$
- $n = \text{Number of motors that are connected (n= 1/2/3/4)}$.

Table 3: Environmental Conditions

Operating Temperature	0°C to 50°C
Storage Temperature	-40°C to 70°C
Operating Humidity	Up to 80%, non-condensing.

Table 4: Analog Input Specifications

Input voltage range:	±10V
Input impedance:	10 kΩ
Input low pass filter:	2.7 kHz

Table 5: Dissipated Heat

Configuration	Input Power (W)	Motor Power (W)	Dissipated Heat (W)
HR1	9.6	6.0	3.6
HR2	19.2	12.0	7.2
HR4	38.4	24.0	14.4
HR8	56.7	48.0	8.7
2HR8	96.0	77.5	18.5
4HR8	230.0	192.0	38.0
STM	7.2	4.0	3.2

* The values given in Table 5 are nominal.

3.2 AB1A-3U Layout

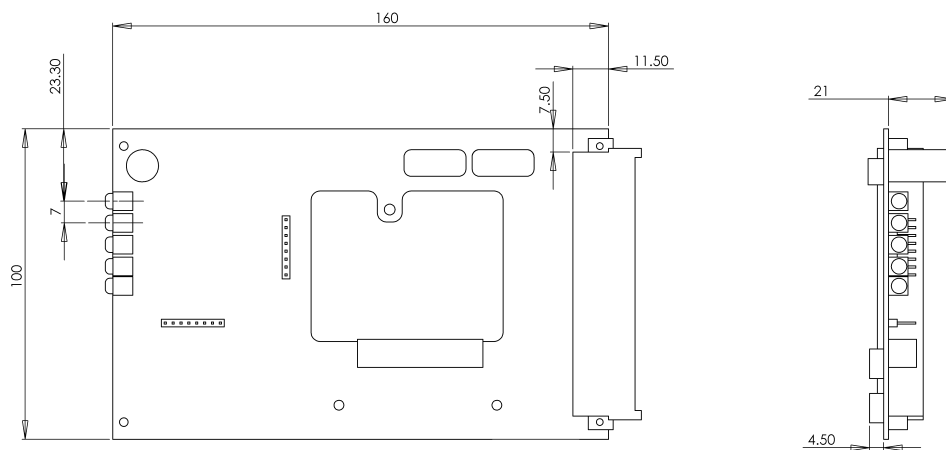

COPY OF DRAWING AB3U-120-000

Figure 9: AB1A-3U Layout

External connector: P/N ERNI 334203, male.

Mating connector: P/N ERNI 344265, female.

3.3 AB1A-3U Pin Arrangement

Table 6: Input/Output Connector Pin Out

Pin	Signal Name	Function	Description
B10	Step	Input	Step mode (see sections 1.4.2.1 and 2.4)
Z10	Enable	Input	Drive enable (see section 2.4)
D12	Emergency stop	Input	Safety input. Disables the drive. (See section 2.4)
D16	Right Switch	Input	Digital Input For Right Limit Switch (See section 2.4)
B16	Left Switch	Input	Digital Input For Left Limit Switch (See section 2.4)
B30, Z30	Motor connected	Input	Safety input. The motor operation is enabled only when this input is shorted to the ground (see section 2.4).
Z14	Gate	Input	Gate Mode (see sections 1.4.3.1 and 2.4)
B12	Fault	Output	Open collector. (see sections 2.5)
D18, D26	VIN -	Input	Negative analog command input (0 to -10V)
B18, B26	VIN +	Input	Positive analog command input (0 to +10V)
D22, B22	Motor COMMON	Output	Connected to the motor 'COMMON' terminal (black wire)
D24, B24	Motor DOWN	Output	Connected to the motor 'DOWN' terminal (white wire)
B28, Z28	Motor UP	Output	Connected to the motor 'UP' terminal (red wire)
B32, Z32	Motor Phase in	Output	Used with an external LC box configuration. Otherwise not used.
D8, B8, Z8	48V	Input	Power supply
D10	User voltage	AUX input	5V External supply
D2	-12V	AUX input	Accessory voltage for powering an external component (max 700 mW). Return is the GND pin.
D6	+12V	AUX input	Accessory voltage for powering an external component (max 700 mW). Return is the GND pin.

Pin	Signal Name	Function	Description
B6	Vcc	AUX output	5V Accessory voltage for powering an external component (max 2.5W). Return is the GND pin.
Z2	SER_CLK	-	Optional. Consult factory.
B2	CS	-	Optional. Consult factory.
D4, B4, Z4	GND		Ground
Z6	SER_DATA	-	Optional. Consult factory.
Z12	Reset	Input	System initialization. Activated short to ground
D14	Reserved		For future use. Must be left unused.
Z16	PTC		For future use. Must be left unused.
Z18	NC		Not in use
D20, B20	Motor phase	Output	Used with an external LC box configuration. Otherwise not used.
Z20	NC		Not in use
Z22	GND		Ground
Z24	GND		Ground
Z26	GND		Ground
D28	GND		Ground
D30	NC		Not in use
D32	NC		Not in use