



AB1A Driver Box User Manual

September 2003

For Further Information Contact

Heason Technologies Group Ltd

Tel: +44(0)1403 755800

Fax: +44(0)1403 755810

Email: sales@heason.com

Freephone 0800 374903 www.heason.com

Heason
Technologies Group

P/N: AB1A 458 000 D

Nanomotion Ltd. POB 223, Yokneam 20692, Israel

Tel: 972-4-959-0862 Fax: 972-4959-0995

Web Site: www.nanomotion.com

E-mail: nano@nanomotion.com

Copyright

This document contains proprietary information of Nanomotion Ltd., and Nanomotion Inc., and may not be reproduced in any form without prior written consent from Nanomotion Ltd. and Nanomotion Inc.

No part of this document may be reproduced, translated, stored in a retrieval system or transmitted in any form and by any means, electronic, mechanical, photographic, photocopying, recording, or otherwise, without the written permission of Nanomotion Ltd.

Information provided in this document is subject to change without notice and does not represent a commitment on the part of Nanomotion Ltd.

Copyright June 2001, Yokneam, Israel. All rights reserved.

All products and company names are trademarks or registered trademarks of their respective holders.

Limited Warranty

Nanomotion Ltd. (hereinafter NM) warrants the product (other than software) manufactured by it to be free from defects in material and workmanship for a period of time of one year (except those parts normally considered as consumable/expendable components such as motor conditioning brushes). The warranty commences thirty (30) days from the date of shipment.

NM warrants those parts replaced under warranty for a period equal to the remaining warranty coverage of the original part.

NM's sole and exclusive obligation under this warranty provision shall be to repair, or at its sole option exchange defective products or the relevant part or component, but only if: (i) the Purchaser reports the defect to NM in writing and provides a description of the defective product and complete information about the manner of its discovery within ten (10) days of its discovery; (ii) NM has the opportunity to investigate the reported defect and determines that the defect arises from faulty material, parts or workmanship; and (iii) the Purchaser returns the affected product to a location designated by NM. These provisions constitute the exclusive remedy of the Purchaser for product defects or any other claim of liability in connection with the purchase or use of NM products.

This warranty policy applies only to NM products purchased directly from NM or from an authorized NM distributor or representative.

This warranty shall not apply to (i) products repaired or altered by anyone other than those authorized by NM; (ii) products subjected to negligence, accidents or damage by circumstances beyond NM control; (iii) product subjected to improper operation or maintenance (i.e. operation not in accordance with NM Installation Manuals and/or instructions) or for use other than the original purpose for which the product was designed to be used.

NM shall not in any event have obligations or liabilities to the Purchaser or any other party for loss of profits, loss of use or incidental, increased cost of operation or delays in operation, special or consequential damages, whether based on contract, tort (including negligence), strict liability, or any other theory or form of action, even if NM has been advised of the possibility thereof, arising out of or in connection with the manufacture, sale, delivery, use, repair or performance of the NM products. Without limiting the generality of the preceding sentence, NM shall not be liable to the Purchaser for personal injury or property damages.

CE Compliance

This product has been tested for Electric Safety and Electromagnetic Compatibility and found to be in compliance with the following directives and standards:

EMC Council Directive 89/336/EEC

Safety Council Directive 73/23/EEC

EN 55011:1998 + A1:1999

EN 61000-6-2:1999

EN 61010-1:1993 + A2:1995

Table of Contents

1	AB1A DESCRIPTION	9
1.1	General	9
1.2	Main Features	9
1.3	Operating Principles.....	10
2	CONNECTIONS AND I/O SETTINGS	12
2.1	AB1A Front Panel	12
2.1.1	Front Panel Connectors.....	12
2.1.2	Front Panel Indicators.....	13
2.2	Motion Controller/Joystick Connection	13
2.2.1	Differential Analog Connection	13
2.2.2	Joystick Connection	16
2.3	Cable Connections.....	17
2.3.1	Shielding	17
2.4	Motor Connections.....	17
2.4.1	Motor Cable Length	17
2.5	Opto-isolated Inputs.....	18
2.5.1	Voltage Source Configuration.....	19
2.6	Fault Output	20
2.7	Before Operating the Motor	20
3	AB1A OPERATION	21
3.1	Operation Modes	21
3.1.1	Velocity Mode Operation	21
3.1.2	Step Mode operation	21
3.1.2.1	Enabling the Step Mode	21
3.1.3	Gate Mode Operation	21
3.1.3.1	Enabling the Gate Mode	22
3.2	Using the AB1A to Drive LS Motors	22
4	SPECIFICATIONS	23
4.1	Parameters and Conditions	23
4.2	AB1A Layout	25
4.3	AB1A Pin Arrangement.....	26

List of Figures

Figure 1: AB1A Block Diagram	10
Figure 2: Schematic Diagram of the Output Stage with an Internal LC Card	11
Figure 3: AB1A Driver Box Front Panel	12
Figure 4: Differential Analog Input Connection	14
Figure 5: Non-Differential (single-ended) Analog Input Connection.	15
Figure 6: Joystick Connection	16
Figure 7: Opto-Isolated Input Interface	18
Figure 8: Jumper 1 Configuration.....	19
Figure 9: AB1A Layout	25

List of Tables

Table 1: AB1A Power Consumption.....	23
Table 2: Electrical Specifications	23
Table 3: Physical dimensions.....	23
Table 4: Environmental Conditions	24
Table 5: Analog Input Specifications.....	24
Table 6: Control Terminal Pin Out.....	26
Table 7: Motor Output Port Pin Out.....	26
Table 8: I/O Connector Pin Out.....	27

List of Abbreviations

A	Ampere
AC	Alternating Current
DC	Direct Current
LC	Coil Capacitor Resonance Circuit
LED	Light Emitting Diode
mA	Milliampere
mW	Milliwatt
TTL	Transistor-Transistor Logic
Vrms	Volts Root Mean Square

New Edition Notes:

This edition is released to reflect the following changes:

1. New mode of operation has been added to the driver: Gate Mode (for more details see Section 3.1.3). This new feature is available in drivers bearing serial numbers 4800 and forward.
2. CE compliance section has been revised.

Other changes to the manual are primarily editorials, aiming to make the manual a more user-friendly one.

1 AB1A Description

1.1 General

The AB1A is a single-axis Amplifier Box designed to drive up to 32 motor elements in parallel.

The AB1A Card consists of DC/DC converters that provide the voltages necessary to operate the amplifier circuit: +5V, $\pm 12V$, +3.3V. In addition, the card contains two LED indicators and the external interface connectors for the INPUT, MOTOR, and I/O signals.

The system configuration may require an LC Card that is connected either internally to the AB1A Card, or externally in a separate LC Box. If the LC Card connection is external, then it is required to connect an adapter card to the AB1A. The adapter card shorts the necessary pins to enable the connection of the external LC Card.

1.2 Main Features

- High precision (11 bits) control of the power output stage
- Drives up to 32 Nanomotion motor elements in parallel
- Three modes of operation: Velocity Mode, Step Mode, and Gate Mode
- Interfaces with an Analog command
- Discrete inputs enable feedback from external sources, such as limit switches, emergency stop command, etc.
- LED indicators
- Reduced sensitivity to cable length and capacitance
- Compact dimensions

1.3 Operating Principles

The AB1A Driver Box comprises the AB1A main card and an LC card. The AB1A Card converts the analog input command signal into a corresponding PWM square wave output signal that is fed to the LC Card. The LC Card produces the sine wave output voltage that drives the motor.

The LC Card type and configuration depends on the number of motor elements driven.

- For 1 to 16 elements, the LC circuit is internal to the AB1A
- For 32 elements, the LC circuit is external to the AB1A (LC Box)

An internal DC-to-DC converter that is fed from an external +48V power supply supplies the required DC voltages.

Figure 1 illustrates a typical application of the AB1A Driver Box.

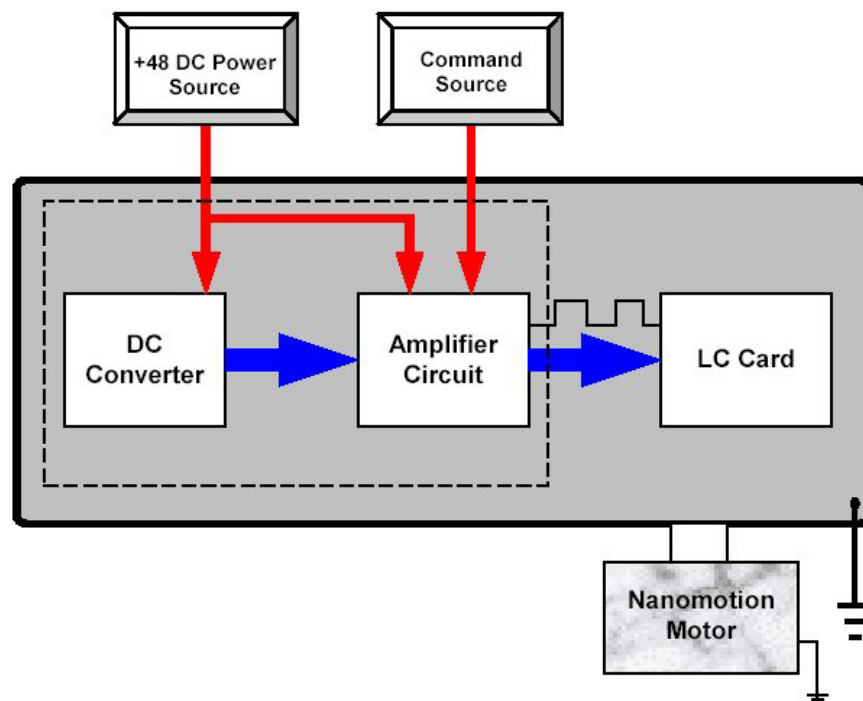

Figure 1: AB1A Block Diagram

The motor has three terminals: "UP" (red wire), "DOWN" (white wire) and "COMMON" (black wire). The voltage applied between the "UP" and the "COMMON" terminals causes the motor to move in one direction, while voltage applied between the "DOWN" and the "COMMON" terminals causes the motor to move in the opposite direction.

Figure 2 is a schematic drawing of the power output.

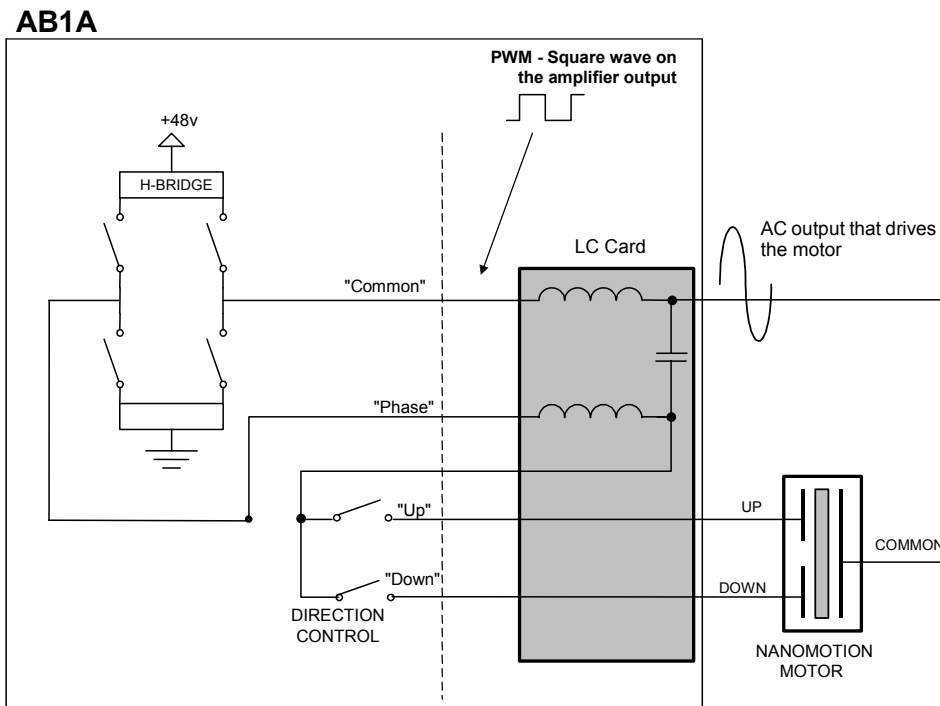

Figure 2: Schematic Diagram of the Output Stage with an Internal LC Card

2 Connections and I/O Settings

2.1 AB1A Front Panel

All AB1A connectors and indicators are located on the front panel. There are three connectors Control Terminal, I/O Port, and Motor Out, and two indicators.

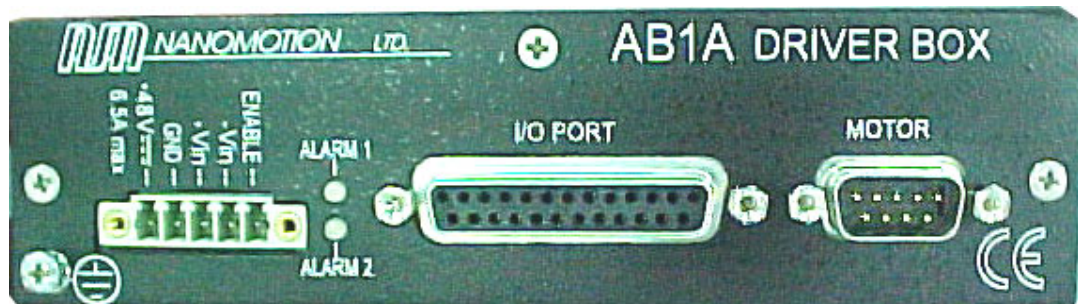

Figure 3: AB1A Driver Box Front Panel

The detailed description of the AB1A connectors and indicators is given sections 2.1.1 and 2.1.2 below.

2.1.1 Front Panel Connectors

Connector	Description
Control Terminal	5-pin connector that provides input from an external +48VDC power supply (6.5A max). Provides direct control of the motor ENABLE signal. See also Table 6
Motor Out	D-type 9 pin connector male -Interfaces to the motor. See also Table 7.
I/O Port	D-type 25 pin connector female - Interfaces to the control source (joystick or controller See also Table 8.

2.1.2 Front Panel Indicators

Condition	Alarm 1	Alarm 2
VCC < 4.6V	Off	Off
Motor Disconnected	Orange	Off
Motor Disabled	Off	Orange
Motor connected and enabled.	Green	Off
Over-current Protection	Red	Red

2.2 Motion Controller/Joystick Connection

The AB1A Driver can receive the input signals either from a motion controller or from a joystick. The schematic diagrams of the motion controller and joystick connections are provided in the following sections.



NOTE:

***The motor may be operated with minimum control signals applied to the Control Terminal:
+48V, GND POWER, +VIN, -VIN, ENABLE_IN.***

2.2.1 Differential Analog Connection

There are two options of connecting a motion controller to the AB1A Driver Box:

- Differential connection (see Figure 4)
- Single-Ended Connection (see Figure 5)

The differential connection enhances noise immunity.

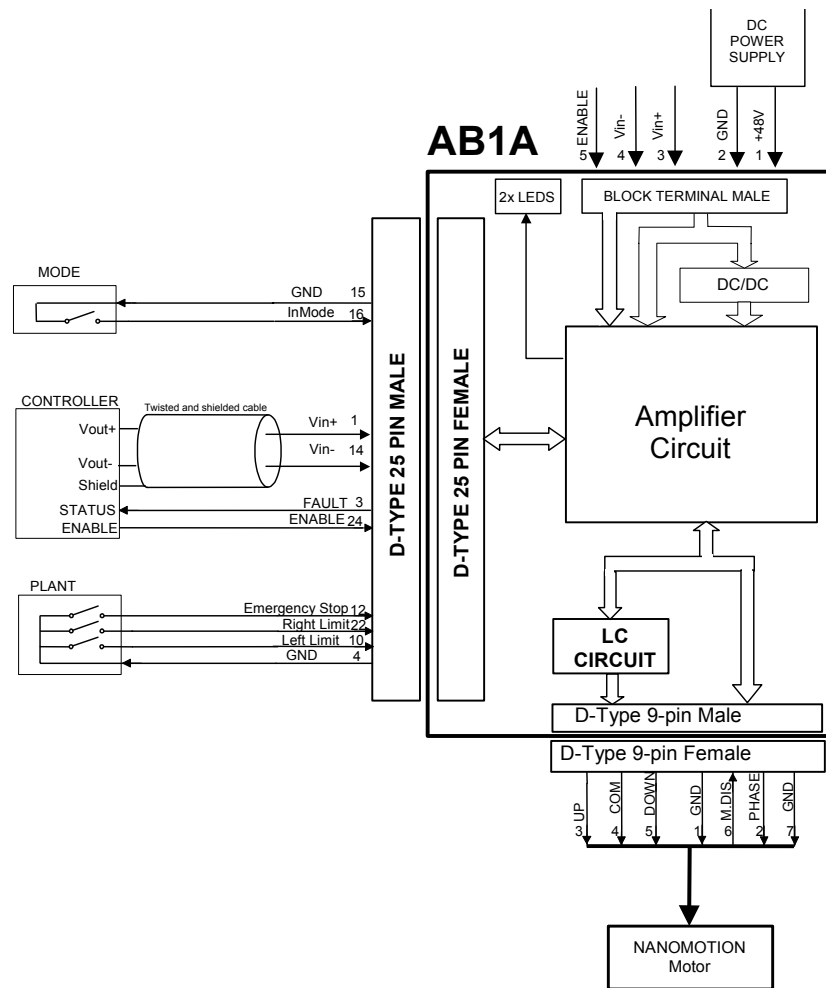

Figure 4: Differential Analog Input Connection

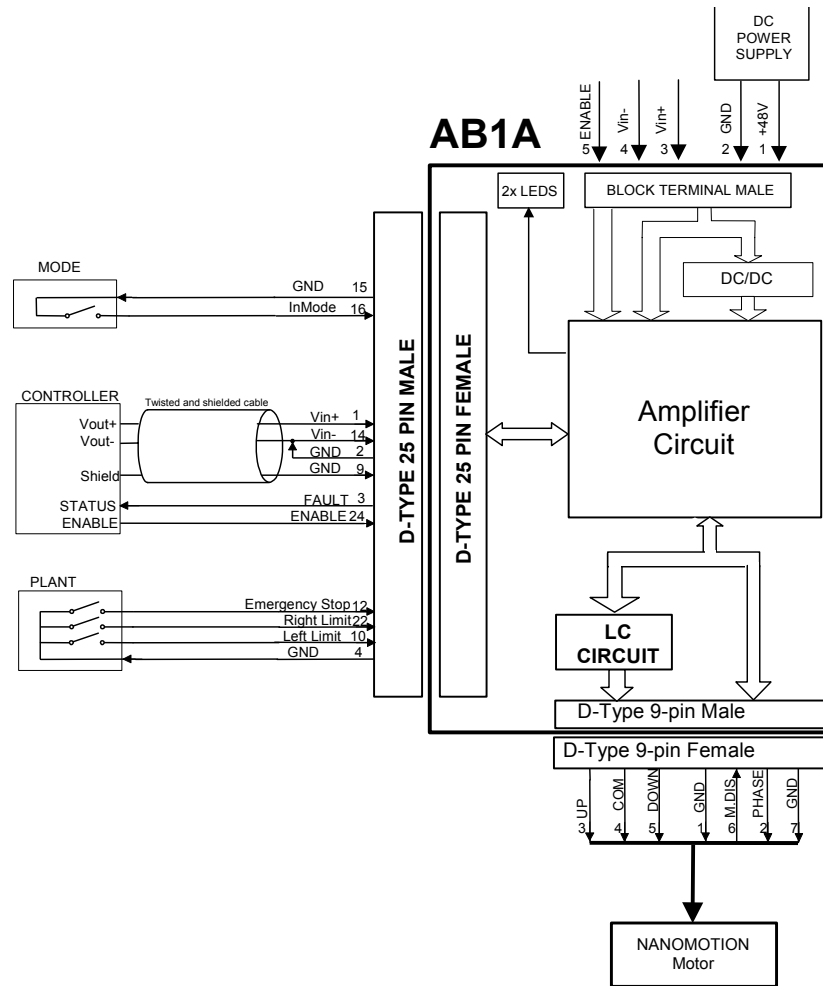

Figure 5: Non-Differential (single-ended) Analog Input Connection.

2.2.2 Joystick Connection

Using the joystick for supplying the command voltage to the AB1A Driver Box allows the user to manually drive the motor without using a motion controller.

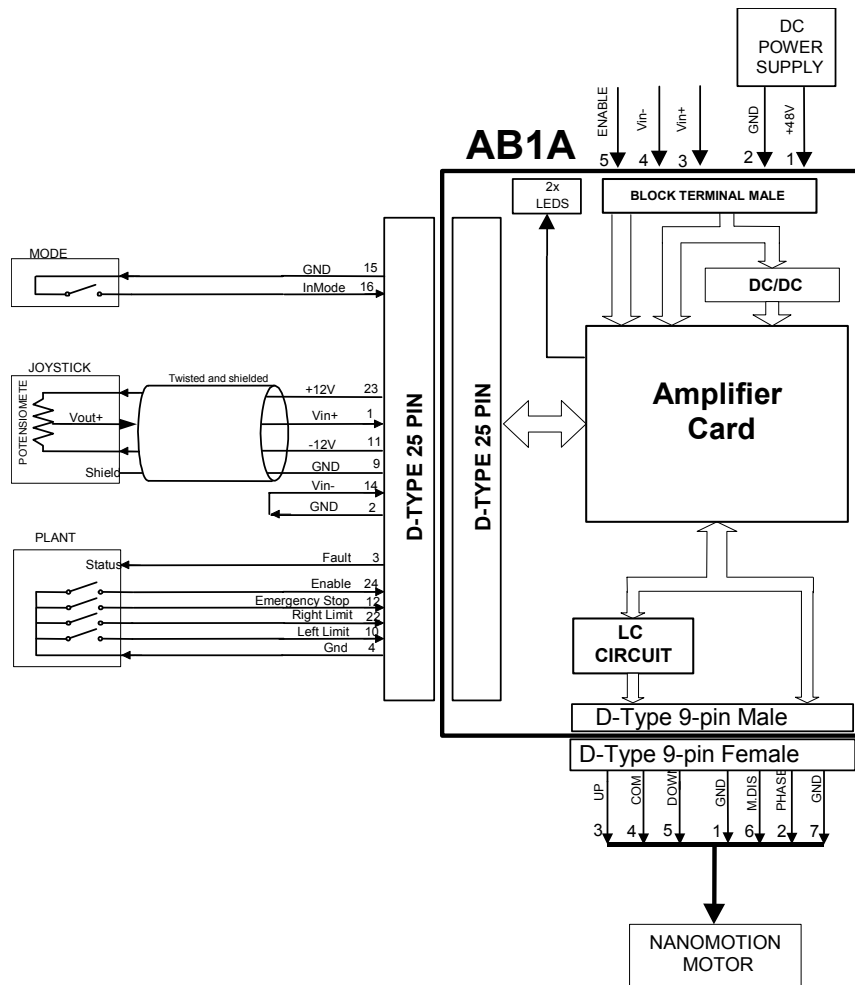

Figure 6: Joystick Connection

2.3 Cable Connections

Connect the following groups of cables together, isolating each of the signals:

- POWER SUPPLIES – use 22 AWG (or lower AWG) wires for the power supplies. For noisy surroundings, it is recommended to twist the ground line and the power line together.
- ANALOG COMMAND – a twisted shielded cable is recommended.
- DISCRETE INPUTS – These signals are not sensitive to noise and can be grouped together in the same harness with any of the other groups.

2.3.1 Shielding

Since the high motor voltage is induced on the cable shield, it is required to ground connection the shield on both sides. Both the driver and the motor should be grounded to the infrastructure earth.

2.4 Motor Connections

The “Motor Connected” signal is available only at the motor connector, where it is shorted to ground. This ensures that unprotected motor pins will not be exposed to high voltage when the motor is not connected.

If more than one motor is connected to the AB1A, use a suitable branch cable.

If the motor type or the number of motor elements is changed, consult Nanomotion for the appropriate driver configuration changes that may be required.

2.4.1 Motor Cable Length

The overall length of the cables that connect the AB1A Driver Box to the motor elements should be in accordance with the following:

- Up to 2 motor elements – 5m
- 4 – 32 motor elements – 10m



NOTE:

Use Nanomotion standard cables. Branching is possible to 2 and 4 identical motors. Branch cables must be of identical length, the sum of which not exceeding the allowed total cable length.



NOTE:

Nanomotion can guarantee proper driver and motor performance only if Nanomotion standard cables are used.

2.5 Opto-isolated Inputs

The following inputs are opto-isolated and are activated by shorting them to ground (see also Table 8):

- Powering Up/Down
 - ◆ **Enable:** Enables the driver activation. Should be activated before the motor is run
 - ◆ **Emergency Stop:** Disables the AB1A output
- Mode Enabling
 - ◆ **Step Mode:** Enables Step Mode operation
- Direction Restrictions
 - ◆ **Left Switch:** Disables motor motion to the left
 - ◆ **Right Switch:** Disables motor motion to the right

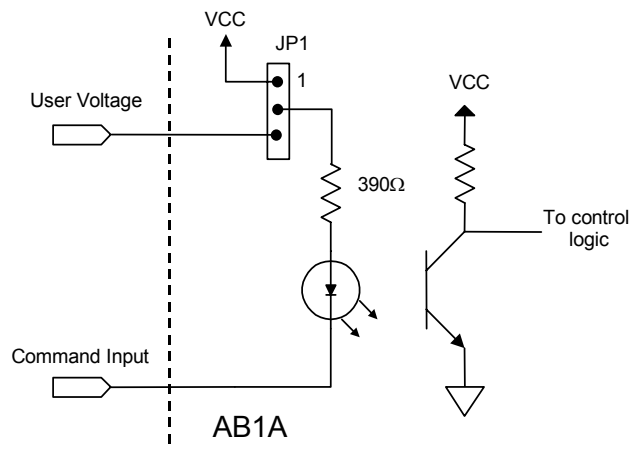

Figure 7: Opto-Isolated Input Interface

2.5.1 Voltage Source Configuration

The opto-isolated input signals are activated as short-to-ground. The voltage for the opto-isolated circuit (see Figure 7) is provided by either the internal +5V supply (default setting) or an external voltage supply via pin 20 on the I/O Port connector. The input to be activated should be shorted to external voltage supply ground.

Configure jumper JP 1 (located near U1) on the AB1A card according to the voltage source:

- Pin 1 shorted to Pin 2, for an internal +5V source (factory setting)
- Pin 2 shorted to Pin 3, for an external voltage source



ATTENTION:

Do not short Pin 1 to Pin 3 on JP2. Doing so shorts the external power supply to the +5V supply! The input circuit is limited to sink up to 10 mA but not less than 3 mA.

Internal voltage source

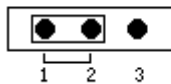
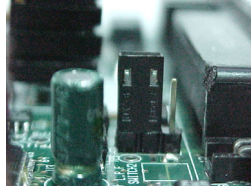

External voltage source

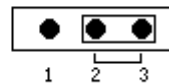
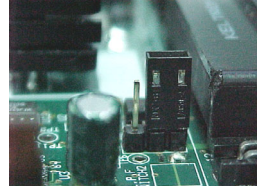

Figure 8: Jumper 1 Configuration

2.6 Fault Output

Fault: An open collector logic output that is active (shorted to ground) under the following conditions:

- The motor is not connected and the “Motor Connected” signal is floating.
- Emergency Stop activated.



NOTE: *The Fault output is capable of sinking a maximum of 20 mA, and is not protected from over current.*

2.7 Before Operating the Motor

Before operating the Motor connected to the AB1A, verify the following:

- Card configuration (as specified on box) matches the motor to be operated.
- Jumper JP1 is set to the required mode of operation.
- All connectors are secured with screws.
- The external power supply is capable of supplying the required power consumption of the AB1A.
- There is no command when switching the power to “ON”.
- Make sure that all motors that are to be driven by the AB1A are correctly mounted and preloaded.



ATTENTION:

- 1. The command should be limited according to the envelope of performance of the motor. Refer to the Motor User Manual.**
- 2. Driver should be grounded to infrastructure earth before operating.**

3 AB1A Operation

3.1 Operation Modes

The AB1A can be operated in one of the following operation modes:

- **Velocity Mode**, in which the motor is driven continuously.
- **Gate Mode**, in which the motor is driven at low velocity by turning the driver output ON and OFF in time intervals defined by outside TTL signal in an open loop.
- **Step Mode**, in which the driver output is turned OFF and ON at predefined intervals, in order to drive the motor in discrete steps.

3.1.1 Velocity Mode Operation

In this operation mode, the motor is driven continuously by applying the analog command voltage (± 10 V) using a relevant interface device (joystick or motion controller).

3.1.2 Step Mode operation

In this operation mode the motor is turned on and off for fixed time intervals defined in the hardware as follows:

- ON phase - 1/16 second
- OFF phase - 0.5 second

The amplitude of the output corresponds to the analog command input value and thus determines the speed of the motor.

3.1.2.1 Enabling the Step Mode

Enable the Step operation mode, by shorting pin 16 (see Table 8) to the ground..

3.1.3 Gate Mode Operation

In this operation mode, the motor is driven at low velocity in open loop by turning the driver output ON and OFF in time intervals defined by an external switching signal.

The amplitude of the output corresponds to the analog command input value and thus determines the speed of the motor.

In Gate Mode, as opposed to Step Mode the pulse width and pulse frequency are user-defined.

The allowable parameter values for the external signal are as follows:

- Voltage level: 0V(on); 5V(off). Open collector logic is also optional.
- Minimum pulse width: 50 μ sec
- Maximum pulse frequency: 1 kHz

3.1.3.1 Enabling the Gate Mode

Enable the Gate mode of operation by shorting pin 21 (see Table 8) to the ground. Verify that pin 16 is not shorted to the ground at the same time. Once pin 21 is shorted, the driver is in Gate Mode. The external signal should now be conducted through pin 16. (See also section 3.1.2)

3.2 Using the AB1A to Drive LS Motors

Under normal conditions, the LS series of motors should not be operated with command voltage exceeding 3.5V. To allow some margin in cases, which require momentarily use of higher power, the AB1A for the LS series of motors is limited to 5V.

Nanomotion expects that during normal operation, the commanding controller should protect the motor, and assumes that in continuous operation the command will not exceed 3.5V. The protection scheme is as follows: the torque limit at the controller must be set to half of the maximum command voltage (5V), and be limited to 5 seconds. The controller RMS torque limit must be set to 35% of the full command.

4 Specifications

4.1 Parameters and Conditions

Table 1: AB1A Power Consumption

Power Input	+48VDC ±5%
Max Motor Output	250-290 Vrms
Power Consumption without Load	+48VDC/0.125A
Power Consumption with Max load	+48VDC/6.5A max

Table 2: Electrical Specifications

Supply Voltage	Current Consumption	Used When
+48v ±5%	≤ 200 mA	1x HR1 is connected.
	≤ 500 mA	1x HR2 is connected.
	≤ 800 mA	1x HR4 is connected.
	≤ 1200 mA	1x HR8 is connected.

The required power supply value should be calculated by adding the total power consumption of all the motors that are connected to the AB1A power consumption without motor (+48VDC/125 mA_{rms}) according to the following:

- $I = 125\text{mA} + n \cdot (\text{current consumption of a single motor})$
- $n = \text{Number of motors that are connected (n= 1/2/3/4)}$.

Table 3: Physical dimensions

Nominal Mechanical Dimensions (WxDxH)	150x110x40
Weight	450 gr.
Mounting options	Desk top/Wall mount

Table 4: Environmental Conditions

Operating Temperature	0°C to 50°C
Storage Temperature	-40°C to 70°C
Operating Humidity	Up to 80%, non-condensing.

Table 5: Analog Input Specifications

Input voltage range:	$\pm 10\text{V}$
Input impedance:	10k Ω
Input low pass filter:	4kHz

4.2 AB1A Layout

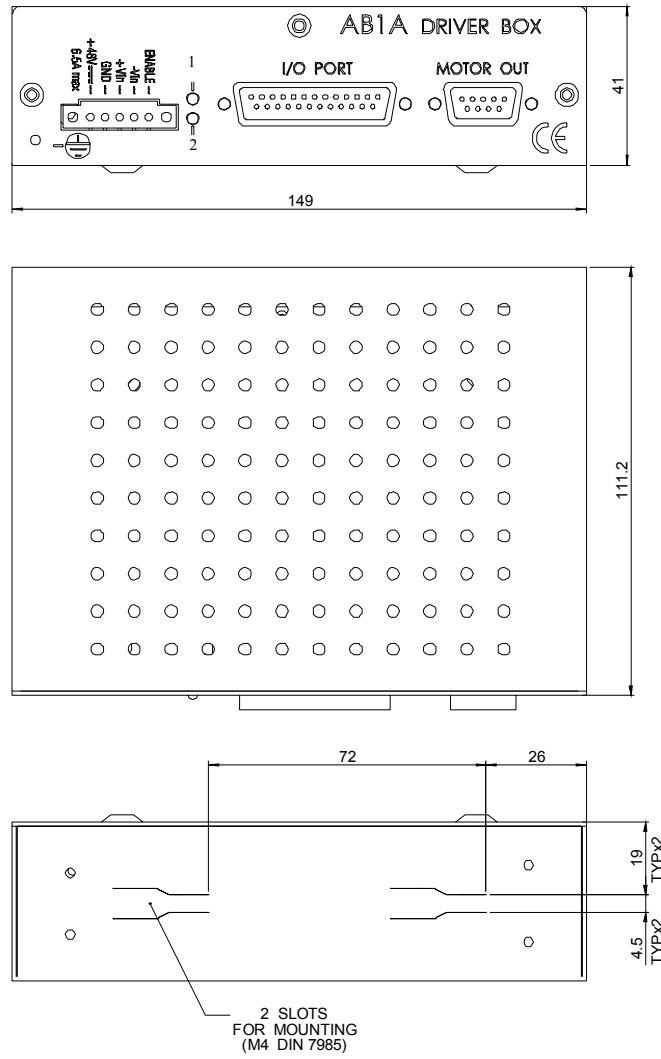

Dimensions in mm
General tolerance ± 0.4

Figure 9: AB1A Layout

4.3 AB1A Pin Arrangement

Table 6: Control Terminal Pin Out

Pin	Signal Name	Function	Description
1	+48V	Input	+48VDC Power Supply
2	GND	Ground	
3	VIN+	Input	Analog Command from controller.
4	VIN-	Input	Analog Command from controller.
5	ENABLE_IN	Input	Enable. See section 2.5

Table 7: Motor Output Port Pin Out

Pin	Signal Name	Function	Description
1	GND	Power supply ground	Safety input; shorted to pin 6 in order to verify the motor connection and prevent the driver operation without the motor.
2	Motor_Phase	High voltage output	Used with an external LC Box Connected to the capacitor in the LC Box; otherwise not connected.
3	Motor_Up	High voltage output	Connected to the white motor terminal.
4	Motor_Common	High voltage output	Connected to the black motor terminal..
5	Motor_Down	High voltage output	Connected to the red motor terminal.
6	Motor Connected	Input	Safety input; shorted to pin 1 in order to verify the motor connection and prevent the driver operation without the motor.
7	GND	Power supply ground	Shorted to the shield
8	Motor in	High voltage output	Used with an external LC Box connected to the AC switch circuit
9	N.C	Not in use	Optional

Table 8: I/O Connector Pin Out

Pin	Signal Name	Function	Description
1	VIN+	Input	Positive analog command input
2	GND		Ground
3	FAULT	Output	See section 2.6
4	GND		Ground
5	NC	Not used	
6	NC	Not used	
7	NC	Not used	
8	NC	Not used	
9	GND		Ground
10	LEFT_LIMIT	Input	Left Limit Switch. See section 2.5
11	-12V	Output	Accessory voltage for powering an external device. (Max 700mW). Return is the GND pin.
12	EMERGENCY_STOP	Input	Protection Input. See section 2.5
13	USER_VOLTAGE	Input	External power supply for the opto-isolated type inputs. (See section 2.5.1)
14	VIN-	Input	Negative analog command input
15	GND		Ground
16	STEP_IN	Input	Gate /Step Selection
17	RESET_IN	Input	Master Reset. Activated shorted to ground
18	NC	Not used	
19	NC	Not used	
20	NC	Not used	
21	GATE	Input	Gate mode enabling
22	RIGHT_LIMIT		Left Limit Switch. See section 2.5
23	+12V	Output	Accessory voltage for powering an external device. (Max 700mW). Return is the GND pin.
24	ENABLE_IN	Input	Enable. See section 2.5
25	+5V	Output	Accessory voltage for powering an external device. (Max 7.5W). Return is the GND pin.