

For Further Information Contact

Heason Technologies Group Ltd

Tel: +44(0)1403 755800

Fax: +44(0)1403 755810

Email: sales@heason.com

Freephone 0800 374903 www.heason.com

Heason
Technologies Group

DANAHER
MOTION

AirBeam™ Single-Axis Shuttle AB-305



Product Dimensions

Dimensions - Top View

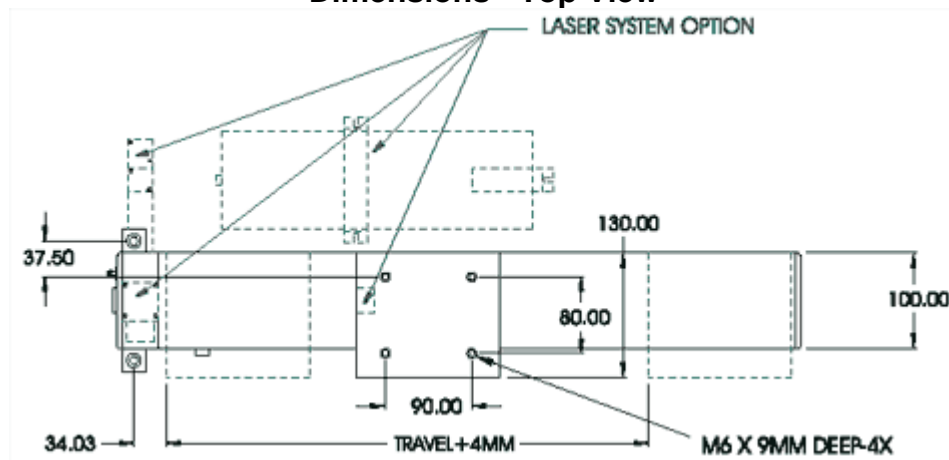

Dimensions - Side View

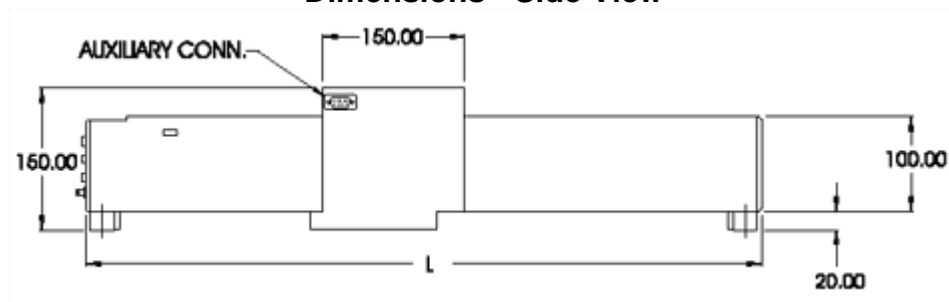

Dimensions - Bottom View



AirBeam™ Single-Axis Shuttle AB-305

Dimensions - End View

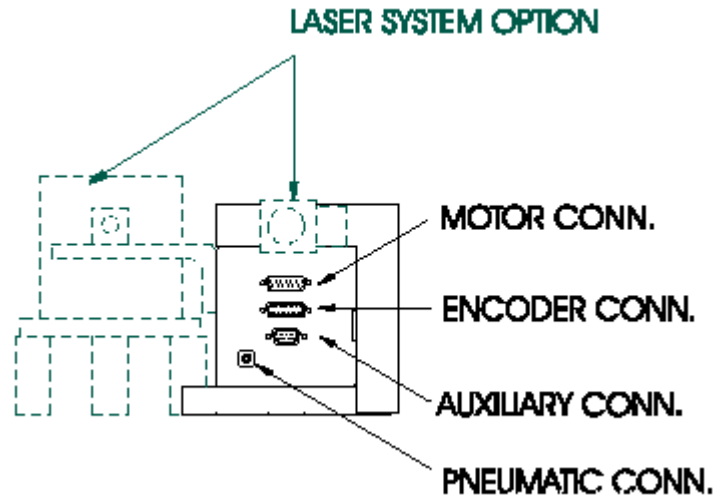

Specifications

Travel (inches)	305
Positional Accuracy (μm) ¹	10
Bidirectional Repeatability (μm)	± 1 count
Flatness & Straightness (μm)	2
Pitch & Yaw (arc-seconds)	10
Load Capacity (kg) ²	10
Maximum Ballscrew Speed (m/sec) ³	1
Mass (kg)	Moving Total
	5.0 10.9

Configurations

Motor	Linear Servo	brushless
Encoder	Linear ($\mu\text{m}/\text{count}$)	1, 0.5, 0.1

Options

Laser Interferometer	
----------------------	--

¹ With 2 point slope correction.

² Please contact our Applications Engineers for loads exceeding 4kg.

³ The maximum speed is encoder and load dependent.